

New Connectivity
CDB420 and CDM490

OPERATING INSTRUCTIONS

CLV490
Bar Code Scanner

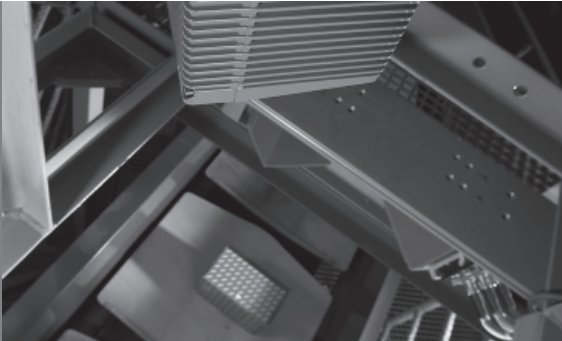

Advanced Line



Software versions

Software/Tool	Function	Version
CLV490-0010/-0011	Firmware	V 5. 0 RA32
CLV490-1010/-1011	Firmware	V 5. 0 RA32
CLV490-6010/-6011	Firmware	V 5. 0 RA32
CLV490-7010/-7011	Firmware	V 5. 0 RA32
CLV490-2010/-2011	Firmware	V 5. 0 RA32
CLV490-3010/-3011	Firmware	V 5. 0 RA32
CLV-Setup	Configuration software (windows-based)	V 4. 4 QF16
CLV-Setup Help	Online help (HTML)	V 4. 4 QF16

Copyright

Copyright © 2004 - 2007
SICK AG Waldkirch
Auto Ident, Reute Plant
Nimburger Strasse 11
79276 Reute
Germany

Trademarks

Windows 95™/98™, Windows NT™, Windows 2000™, Windows XP™ and Internet Explorer™ are registered trademarks or trademarks of the Microsoft Corporation in the USA and other countries.

Acrobat™ Reader™ is a trademark of the Adobe Systems Incorporated

Latest manual version

For the latest version of this manual (PDF), see www.sick.com.

CLV490 Bar Code Scanner

Quick Finder

- **What is delivered with the device**
 - [Chapter 3.1.1 Scope of delivery, Page 3-1](#)
- **CAUTION!**
 - [Chapter 2 Safety information, Page 2-1](#)
- **Mounting the device at the reading station**
 - [Chapter 4 Installation, Page 4-1](#)
- **Connecting the device**
 - [Chapter 5 Electrical installation, Page 5-1](#)
- **Overview of the device and its functions**
 - [Chapter 3 Product description, Page 3-1](#)
 - [Chapter 6.2 Default settings, Page 6-1](#)
 - [Chapter 6.5 Operating modes and outputting the reading result, Page 6-38](#)
 - [Chapter 9 Technical data, Page 9-1](#)
 - [Chapter 10.3 Installing and operating the external parameter memory \(connector cover\), Page 10-34](#)
- **Starting the device with the default settings**
 - [Chapter 6.3 Quick start, Page 6-3](#)
- **Installing the "CLV-Setup" program**
 - [Chapter 10.6 Installing and operating the "CLV-Setup" program, Page 10-43](#)
- **Adapting the device to the reading application**
 - [Chapter 6.4 Configuring \(parameterization\) the CLV490, Page 6-5](#)
- **Troubleshooting**
 - [Chapter 8 Troubleshooting, Page 8-1](#)
- **Finding information**
 - [Table of contents, Page I-5](#)
 - [Index, Page 10 -95](#)



Installation procedure (overview)

CLV490 in stand-alone configuration (without heating)

Start/stop mode: Reading trigger via "Sensor" switching input (default setting)

1. Check the delivery to make sure that none of the components is missing.
2. Mount the CLV490 at the reading station/ align it with the object carrying the bar code.
3. Mount the CDB420 or CDM490 Connection Module.
4. Connect the CLV490 as followed:
CDB420 Connection Module: using the cable no. 2027046. Alternatively, connect the CLV490 using the external parameter memory no. 2030023.
CDM490 Connection Module: using two cables no. 2020302. Alternatively, connect the CLV490 using the external parameter memory no. 2020307.
5. Mount the sensor for starting/stopping the reading pulse.
6. Connect the reading pulse sensor to the "Sensor (1)" input in the CDB420 or CDM490.
7. Connect the host to the host interface in the CDB420 or CDM490.
8. Switch on the power supply to the CDB420 or CDM490.
The "Device Ready" LED lights up after the CLV490 has started.

CLV490 with empty parameter memory connected (no. 2020307 or no. 2030023):
After the CLV490 has started, it copies the internal parameter set to the external parameter memory if no CMC400 parameter memory is available in the CDB420/ CDM490.

Line scanner with oscillating mirror:

In the default setting, the CLV490 deflects the scan line around the position $CW = 50$ with a frequency of 1 Hz and an oscillating amplitude of max. $\pm 20^\circ$ (± 40 CW).

9. Switch on your PC and start Windows™ (minimum requirement: Windows 95™).
10. Install the "CLV-Setup" software and the online CLV-Setup Help from the CD-ROM ("Manuals & Software") on your PC.
11. Connect the PC to the auxiliary interface of the CLV490. To do so, connect a 3-core RS 232 data cable (null modem cable), e. g. no. 2014054 to the "Aux" plug in the CDB420 or CDM490.
12. Start the "CLV-Setup" program.
CLV-Setup establishes communication with the CLV490 and uploads the parameter set. The parameters are then displayed on the tabs.
13. Carry out a test read using test bar codes (clock the CLV490 accordingly).
Display the reading result in the Terminal Emulator window of the "CLV-Setup" program.
14. Configure the CLV490 for the application using the settings on the tabs in CLV-Setup.
Copy (download) the modified parameter set to the CLV490 temporarily.
Do **not** switch off the power supply to the CDB420 or CDM490 (CLV490)!
15. Test the application under realistic conditions.
16. Check whether the data is transmitted correctly between the CLV490 and host.
17. If necessary, correct and optimize the parameter values.
Copy (download) the parameter set **permanently** to the CLV490.
CLV490 with external parameter memory connected:
Copy the modified parameter set to the external parameter memory when CLV-Setup asks you for confirmation.
18. Save the parameter set as a configuration file "*.scl" in the "CLV-Setup" program.

The CLV490 can then be operated with the **application-specific** settings.

Table of contents

1	Notes on this document.....	1-1
1.1	Purpose	1-1
1.2	Target audience.....	1-1
1.2.1	Mounting, electrical installation, maintenance and replacement.....	1-1
1.2.2	Startup, operation and configuration.....	1-1
1.3	Information content.....	1-2
1.4	Symbols.....	1-2
2	Safety information.....	2-1
2.1	Authorized users	2-1
2.1.1	Mounting and maintenance	2-1
2.1.2	Electrical installation and replacement	2-1
2.1.3	Startup, operation and configuration.....	2-1
2.2	Intended use.....	2-1
2.3	General safety instructions and protection measures	2-2
2.4	Quick stop and quick restart.....	2-4
2.4.1	Stopping the CLV490.....	2-4
2.4.2	Restarting the CLV490	2-4
2.5	Environmental information.....	2-4
2.5.1	Power requirements.....	2-4
2.5.2	Disposal after removal from service.....	2-4
3	Product description	3-1
3.1	Design	3-1
3.1.1	Scope of delivery.....	3-1
3.1.2	Variants.....	3-1
3.1.3	System requirements for stand-alone configuration.....	3-2
3.1.4	Product features and functions (overview)	3-3
3.1.5	Design	3-5
3.2	Method of operation.....	3-6
3.2.1	Autofocus function.....	3-7
3.2.2	Event-controlled dynamic focus control	3-8
3.2.3	Reading modes of the CLV490 in stand-alone configuration.....	3-8
3.2.4	Scan procedure variants	3-9
3.2.5	Additional components	3-10
3.3	Indicators and control elements	3-10
3.3.1	Control elements.....	3-10
3.3.2	Function of the LEDs.....	3-11
4	Installation	4-1
4.1	Installation sequence	4-1
4.2	Preparations.....	4-1
4.2.1	Required components.....	4-1
4.2.2	Required accessories.....	4-1
4.2.3	Required auxiliary parts	4-1
4.2.4	Replacing the laser warning label	4-2
4.2.5	Selecting the mounting location	4-2
4.2.6	Mounting accessories.....	4-2
4.2.7	Distance between the CLV490 and the object.....	4-4
4.2.8	Count direction of the reading angle RA and code angle CW.....	4-6
4.3	Mounting and adjusting the device	4-7
4.3.1	Mounting the CLV490.....	4-7
4.3.2	Adjusting the CLV490	4-8
4.3.3	Adjusting mode	4-10
4.4	Mounting the external components.....	4-11
4.4.1	Mounting the CDB420 or CDM490 Connection Module.....	4-11
4.4.2	Mounting the external reading pulse sensor.....	4-11
4.4.3	Installing incremental encoder	4-12

4.4.4	Mounting the sensors for detecting the object distance	4-13
4.5	Dismantling the device	4-14
5	Electrical installation	5-1
5.1	Installation sequence.....	5-1
5.1.1	SICK Connection Modules (overview).....	5-1
5.2	Electrical connections and cables	5-1
5.2.1	Wire cross-sections	5-1
5.2.2	Prefabricated cables (overview)	5-2
5.2.3	Connections/cables for the CDB420 Connection Modules	5-3
5.2.4	Connections/cables for the CDM490 Connection Module	5-5
5.2.5	Connections/cables for a non-SICK power pack	5-6
5.3	Connector pin assignment.....	5-7
5.3.1	Terminals on the CLV490	5-7
5.3.2	Cable no. 2027046 (connector cover) Cable no. 2030023 (connector cover with parameter memory)	5-8
5.3.3	Cable no. 2020307 (connector cover with parameter memory)	5-9
5.3.4	Cable no. 2033126/2033127 (connector cover with parameter memory)	5-10
5.3.5	Cable no. 2030065/2031034 (connector cover with parameter memory)	5-11
5.3.6	Cable no. 2020303	5-13
5.3.7	Cable no. 2020264	5-13
5.3.8	Cable no. 2020981 (connector cover with parameter memory)	5-14
5.3.9	Cable no. 2021267 (connector cover)	5-15
5.4	Preparations for electrical installation.....	5-16
5.4.1	Requirements for the host interface	5-16
5.4.2	Supply voltage	5-16
5.4.3	Non-SICK Power supply unit/connections without the Connection Module.....	5-17
5.5	Electrical installation procedure	5-18
5.5.1	Individual steps.....	5-18
5.5.2	Tools	5-18
5.5.3	Connecting the supply voltage	5-18
5.5.4	Connecting the host interface	5-20
5.5.5	Connecting the CAN interface	5-21
5.5.6	Connecting the PC.....	5-21
5.5.7	Connecting the "Sensor" switching input.....	5-22
5.5.8	Connecting the "IN 0" to "IN 4" switching inputs.....	5-23
5.5.9	Connecting the "Result 1" to "Result 4" switching outputs	5-26
6	Operation	6-1
6.1	Overview of steps for starting up the CLV490.....	6-1
6.2	Default settings	6-1
6.2.1	Default settings of the line scanner CLV490 (all variants)	6-2
6.2.2	Default settings of the line scanner with oscillating mirror CLV490 (all variants).....	6-2
6.3	Quick start.....	6-3
6.3.1	Starting up the CLV490 with the factory default settings.....	6-3
6.4	Configuring (parameterization) the CLV490	6-5
6.4.1	Configuring the CLV490 via the user interface of CLV-Setup	6-5
6.4.2	Function of the tabs in CLV-Setup (overview)	6-7
6.4.3	Parameterizing example	6-9
6.4.4	Guide to parameterization menu.....	6-9
6.5	Operating modes and outputting the reading result.....	6-38
6.5.1	Reading mode (standard operating mode)	6-38
6.5.2	Percentage evaluation.....	6-41
6.5.3	Adjusting mode.....	6-43
6.5.4	Background teach-in	6-44

6.5.5	Show RA-limits.....	6-46
6.5.6	Background Analysis.....	6-47
6.5.7	I/O monitor in increment trigger	6-48
6.5.8	Displaying and editing operating data.....	6-53
6.5.9	Reading diagnosis.....	6-54
6.5.10	Monitor Host Interface	6-54
6.5.11	Auxiliary input.....	6-56
6.5.12	Code statistics for RDT400.....	6-56
6.5.13	Self-test.....	6-57
6.5.14	Executing CLV490 functions interactively	6-58
6.6	CLV490 messages	6-59
6.6.1	Displaying messages.....	6-59
6.6.2	Error messages	6-59
6.7	Switching off the CLV490	6-60
7	Maintenance	7-1
7.1	Maintenance during operation.....	7-1
7.2	Cleaning the CLV490	7-1
7.2.1	Cleaning the front window	7-1
7.2.2	Cleaning other optical surfaces	7-2
7.3	Checking the incremental encoder	7-3
7.4	Disposal.....	7-3
8	Troubleshooting.....	8-1
8.1	Overview of possible errors and malfunctions	8-1
8.1.1	Mounting errors	8-1
8.1.2	Electrical installation errors.....	8-1
8.1.3	Parameter errors.....	8-1
8.1.4	Malfunctions.....	8-1
8.2	Monitoring error and malfunctions.....	8-1
8.3	Error messages	8-2
8.3.1	CLV490 without external parameter memory	8-2
8.3.2	LED error messages for the external parameter memory (connector cover).....	8-3
8.3.3	Messages for errors accessing the external parameter memory (connector cover).....	8-5
8.4	ST error status in the reading result of a bar code.....	8-7
8.5	Troubleshooting.....	8-9
8.5.1	General malfunctions: CLV490 not ready.....	8-9
8.5.2	Malfunctions in Reading mode: reading trigger errors.....	8-10
8.5.3	Malfunctions in Reading mode: result output errors.....	8-14
8.5.4	Malfunctions in Reading mode: errors in the result status output.....	8-18
8.5.5	Malfunctions in Reading mode: oscillating mirror errors.....	8-19
8.6	SICK Support	8-20
9	Technical data	9-1
9.1	Data sheet CLV490-0010/-2010/-6010 bar code scanner	9-1
9.2	Data sheet CLV490-1010/-3010/-7010 bar code scanner	9-2
9.3	Data sheet CLV490-0011 /-2011/-6011 bar code scanner	9-3
9.4	Data sheet CLV490-1011/-3011/-7011 bar code scanner	9-3
9.5	Dimensioned drawings – CLV490	9-4
9.5.1	Line scanner (standard device) without /with heater	9-4
9.5.2	Line scanner with oscillating mirror (without/with heater)	9-5
10	Appendix	10-1
10.1	Overview.....	10-1
10.2	Specification diagrams.....	10-1
10.2.1	Reading conditions for all diagrams.....	10-1
10.2.2	Overview of diagrams.....	10-2
10.2.3	Standard density: Reading performance data of line scanner.....	10-3
10.2.4	Standard density: Reading performance data of line scanner with	

oscillating mirror.....	10-9
10.2.5 High density: Reading performance data of line scanner.....	10-16
10.2.6 High density: Reading performance data line scanner with oscillating mirror.....	10-21
10.2.7 Low density: Reading performance data of line scanner.....	10-27
10.2.8 Low density: Reading performance data of line scanner with oscillating mirror.....	10-31
10.3 Installing and operating the external parameter memory (connector cover).....	10-34
10.3.1 Function of the external parameter memory.....	10-35
10.3.2 Installation and electrical connection.....	10-36
10.3.3 Operation.....	10-36
10.3.4 Switching on the device for the first time.....	10-37
10.3.5 Adjusting the parameter set in the external parameter memory (connector cover) after it has been downloaded to the CLV490	10-37
10.3.6 Meaning of the LEDs.....	10-38
10.3.7 Error messages.....	10-38
10.3.8 Replacing a CLV490.....	10-39
10.4 Optional heating.....	10-40
10.4.1 Features.....	10-40
10.4.2 Design.....	10-40
10.4.3 Function.....	10-40
10.4.4 Electrical installation	10-41
10.4.5 Outdoor applications	10-41
10.5 System messages	10-42
10.5.1 CLV490 without external parameter memory.....	10-42
10.5.2 CLV490 with external parameter memory connected	10-42
10.6 Installing and operating the "CLV-Setup" program.....	10-43
10.6.1 Preparations	10-43
10.6.2 Installing the software.....	10-43
10.6.3 Starting CLV-Setup.....	10-46
10.6.4 User interface.....	10-48
10.6.5 Functions	10-49
10.6.6 Hot keys	10-49
10.6.7 Opening and closing tabs.....	10-50
10.6.8 Online help – CLV-Setup Help	10-50
10.6.9 Transferring parameter sets between CLV-Setup and the CLV490	10-51
10.6.10 Unknown parameters.....	10-51
10.6.11 Log file in the Terminal Emulator	10-52
10.6.12 Starting CLV-Setup with an "INI file" as an argument.....	10-52
10.6.13 The CLV Assistant.....	10-52
10.7 Configuring a CLV490 with command strings.....	10-53
10.8 Calculating parameter values for setting the CLV490.....	10-55
10.8.1 Calculating the number of scans (for standard decoder).....	10-55
10.8.2 Calculating the start position and mirror speed for the forward and return phase of the One-Shot function	10-57
10.8.3 Calculating the necessary capture area for the bar code if several bar codes are read on each object.....	10-58
10.9 Tables	10-59
10.9.1 Calculating the code length of a bar code.....	10-59
10.10 Discussion of a parameterization example.....	10-60
10.10.1 Application Conditions	10-60
10.10.2 Purpose of this discussion.....	10-60
10.10.3 Instructions for solution – step by step	10-60
10.10.4 Important clarifications	10-61
10.10.5 Mounting and electrical connection	10-61

- 10.10.6 Parameterize the CLV490 with the "CLV-Setup" program10-62
- 10.10.7 Testing the application10-68
- 10.11 Special applications and procedures10-69
 - 10.11.1 Auxiliary input via auxiliary interface10-69
 - 10.11.2 Connection to Profibus DP.....10-72
 - 10.11.3 Connection to the DeviceNet.....10-72
 - 10.11.4 Connection to Ethernet TCP/IP.....10-72
 - 10.11.5 Building a CAN Scanner Network.....10-72
 - 10.11.6 Integration in an OPS reading system.....10-72
- 10.12 Replacing a CLV490 (copying the parameter set)10-73
 - 10.12.1 Downloading the parameter set.....10-73
 - 10.12.2 Importing the parameter set from the external memory.....10-74
- 10.13 Ordering Information.....10-75
 - 10.13.1 CLV490 Bar Code Scanner.....10-75
 - 10.13.2 Accessories: Mounting devices10-75
 - 10.13.3 Accessories: Hoods10-75
 - 10.13.4 Accessories: Connection modules10-76
 - 10.13.5 Accessories: Extensions for connection modules.....10-77
 - 10.13.6 Accessories: Cables, external parameter memories in
connector cover, connector covers10-79
 - 10.13.7 Plug-in connections10-82
 - 10.13.8 Reading pulse generators.....10-82
 - 10.13.9 Incremental encoder.....10-82
- 10.14 Dimensioned drawings of the accessories.....10-83
 - 10.14.1 Angle bracket, single no. 2013824.....10-83
 - 10.14.2 Articulated bracket, No. 2018435.....10-83
 - 10.14.3 Quick clamping device, No. 2016110.....10-83
 - 10.14.4 Hinge bracket, No. 2022996.....10-84
 - 10.14.5 Mirror hood, No. 203207010-84
- 10.15 Supplementary documentation10-85
 - 10.15.1 CLV Connect (from version 1.9)10-85
- 10.16 Glossary10-86
- 10.17 EC Declaration of Conformity10-94
- 10.18 Index10-95
- 10.19 Bar code example10-101

Abbreviations

CAN	C ontroller A rea N etwork (standard field bus system with message-orientated data exchange protocol)
CDB	C onnection D evice B asic
CDM	C onnection D evice M odular
CMF	C onnection M odule F ieldbus
CLV	C ode- L eser V -Prinzip.
CMC	C onnection M odule C loning
CMD	C onnection M odule D isplay
CMP	C onnection M odule P ower
DC	D istance C onfiguration
DOF	D epth O f F ield
EEPROM	E lectrically E rasable P rogrammable R ead O nly M emory
FIFO	First in, first out
HD	H igh D ensity
HTML	H yper T ext M arkup L anguage (page-description language on the internet)
LED	L ight E mitting D iode
LIFO	Last in, first out
MTBF	M ean T ime B etween F ailure
PLC	P rogrammable L ogic C ontroller
RAM	R amdom A cces M emory
ROM	R ead O nly M emory
RTF	R ich T ext F ormat (standard document format with format descriptions)
SMART	S ICK M odular A dvanced R ecognition T echnology

Tables

Table 3-1:	CLV490 variants.....	3-1
Table 3-2:	Meaning of LEDs: CLV490 without external parameter memory	3-11
Table 3-3:	Meaning of LEDs: CLV490 with external parameter memory in the connector cover.....	3-12
Table 4-1:	Permissible reading angles between the scan line and bar code	4-5
Table 5-1:	Connection Modules for the CLV490	5-1
Table 5-2:	Cables for connecting the CLV490.....	5-2
Table 5-3:	Pin assignment of the 15-pin D Sub HD "Host/Term" plug	5-7
Table 5-4:	Pin assignment of the 15-pin D Sub HD "I/O" socket.....	5-7
Table 5-5:	Pin assignment: 15-pin D Sub HD plug of the cable no. 2027046/ no. 2030023.....	5-8
Table 5-6:	Pin assignment: 15-pin D Sub HD plug of the cable no. 2020307.....	5-9
Table 5-7:	Pin assignment: 15-pin D Sub HD socket of the cable no. 2020307.....	5-9
Table 5-8:	Pin assignment: 15-pin D Sub HD plug of the cable no. 2033126/ no. 2033127.....	5-10
Table 5-9:	Pin assignment: open end of the cable no. 2033126/no. 2033127	5-10
Table 5-10:	Pin assignment: 15-pin D Sub HD plug of the cable no. 2030065/ no. 2031034.....	5-11
Table 5-11:	Pin assignment: 15-pin D Sub HD socket of the cable no. 2030065/ no. 2031034.....	5-11
Table 5-12:	Pin assignment: open end of the cable no. 2030065/no. 2031034	5-12
Table 5-13:	Pin assignment: 15-pin D Sub HD socket/wire colors of cable	

	no. 2020303	5-13
Table 5-14:	Pin assignment: 15-pin D Sub HD plug/wire colors of cable no. 2020264	5-13
Table 5-15:	Wire colors of cable no. 2020981, cable 1 ("Host/Term" connection) ...	5-14
Table 5-16:	Wire colors of cable no. 2020981, cable 2 ("I/O" connection)	5-14
Table 5-17:	Wire colors of cable no. 2021267, cable 1 (connection for data and function interfaces)	5-15
Table 5-18:	Wire colors of cable no. 2021267, cable 2 (connection for power supply).....	5-15
Table 5-19:	Maximum cable lengths between the CLV490 and host	5-16
Table 5-20:	Power consumption of the CLV490	5-16
Table 5-21:	Power-up delay as a function of the device number GN	5-16
Table 5-22:	Communication parameters for the host interface (default setting)	5-20
Table 5-23:	Characteristic data of the "Sensor" switching input.....	5-22
Table 5-24:	Pin assignment for "IN 0" to "IN 4" switching inputs.....	5-24
Table 5-25:	Characteristic data of the "IN 0" to "IN 4" switching inputs	5-24
Table 5-26:	Dynamic focus control: switching inputs/distance configuration assignment table	5-24
Table 5-27:	Combination of the functions of the "IN 0" to "IN 4" switching inputs	5-25
Table 5-28:	Pin assignment for "Result 1" to "Result 4" switching outputs	5-26
Table 5-29:	Characteristic data of the "Result 1" to "Result 4" switching outputs.....	5-26
Table 6-1:	Extract: Default parameter settings of the line scanner CLV490-0010/-0011	6-2
Table 6-2:	Extract: Default parameter settings of the line scanner with oscillating mirror CLV490	6-2
Table 6-3:	Reading distances for default settings.....	6-4
Table 6-4:	Guide: Configuring the reading area.....	6-11
Table 6-5:	Guide: Selecting the focus control mode.....	6-12
Table 6-6:	Guide: Configuring the autofocus function (part 1)	6-13
Table 6-7:	Configuring the autofocus function (part 2)	6-15
Table 6-8:	Guide: Configuring focus position switchover.....	6-16
Table 6-9:	Guide: Configuring oscillating mirror functions	6-17
Table 6-10:	Overview: CLV490 applications in stand-alone configuration or in arrangement with OTS400	6-21
Table 6-11:	Guide: Parameterizing the reading trigger for start/stopp mode in stand-alone configuration	6-22
Table 6-12:	Guide: Parameterizing internal object tracking.....	6-27
Table 6-13:	Guide: Parameterizing the reading mode for tracking mode in stand-alone configuration	6-29
Table 6-14:	Guide: Parameterizing focus control in CLV490 for master/ slaves arrangement with OTC400	6-30
Table 6-15:	Guide: Parameterizing reading trigger in the CLV490 for master/ slave arrangement with OTC400	6-31
Table 6-16:	Guide: Parameterizing slave mode in the CLV490 for arrangement with OTC400 (master)	6-31
Table 6-17:	Guide: Parameterizing operation mode in the OTC400 for master/ slaves arrangement.....	6-32
Table 6-18:	Guide: Parameterizing focus control in CLV490 for object tracking mode with OTC400	6-33
Table 6-19:	Guide: Parameterizing reading trigger in the CLV490 for object tracking mode with OTC400	6-34
Table 6-20:	Guide: Parameterizing tracking in the CLV490 for object tracking mode with OTC400	6-34
Table 6-21:	Guide: Parameterizing slave mode in the CLV490 for object tracking mode with OTC400	6-35
Table 6-22:	Guide: Parameterizing tracking mode in the OTC400.....	6-35
Table 6-23:	Guide: Parameterizing the laser timeout.....	6-36

Table 6-24:	Guide: Parameterizing the separation of identical bar codes.....	6-36
Table 6-25:	"Monitor Host Interface" function.....	6-54
Table 8-1:	Error messages output on the auxiliary interface.....	8-2
Table 8-2:	LED error messages for access to the external parameter memory (connector cover).....	8-3
Table 8-3:	Messages for problems accessing the external parameter memory (connector cover).....	8-5
Table 8-4:	Meaning of the ST error status in the reading result	8-7
Table 8-5:	Troubleshooting: restoring operation (Reading mode).....	8-9
Table 8-6:	Troubleshooting: reading trigger errors in Reading mode (CLV490 in stand-alone configuration).....	8-10
Table 8-7:	Troubleshooting: reading trigger errors in Reading mode (CLV490 integrated in OTS400 Omni Tracking System).....	8-13
Table 8-8:	Troubleshooting: result output errors in Reading mode (CLV490 in stand-alone configuration).....	8-14
Table 8-9:	Troubleshooting: result output errors in Reading mode (CLV490 integrated in the OTS400 Omni Tracking System)	8-17
Table 8-10:	Troubleshooting: errors in the result status output in Reading mode	8-18
Table 8-11:	Troubleshooting: oscillating mirror errors in Reading mode.....	8-19
Table 9-1:	Technical specifications of the CLV490-0010/-2010/-6010.....	9-1
Table 9-2:	Technical specifications of the CLV490-1010/-3010/-7010.....	9-2
Table 9-3:	Technical specifications of the CLV490-0011/-2011/-6011.....	9-3
Table 9-4:	Technical specifications of the CLV490-1011/-3011/-7011.....	9-3
Table 10-1:	Reading conditions for specification diagrams.....	10-1
Table 10-2:	Overview of specification diagrams for the line scanner	10-2
Table 10-3:	Overview of specification diagrams for the line scanner with oscillating mirror.....	10-2
Table 10-4:	Types of the external parameter memory in the connector cover.....	10-34
Table 10-5:	CLV490 system messages.....	10-42
Table 10-6:	Additional CLV490 system messages for the connected parameter memory	10-42
Table 10-7:	Default settings in CLV-Setup.....	10-46
Table 10-8:	Formulas for calculating the code length of a bar code	10-59
Table 10-9:	Communication parameters on the terminal/PC for the auxiliary input	10-71
Table 10-10:	Communication parameter settings for the SICK Hand-held Scanner from the IT 38xx/46xx/48xx/58xx series.....	10-71
Table 10-11:	CLV490 variants.....	10-75
Table 10-12:	Accessories: mounting accessories	10-75
Table 10-13:	Accessories: Hood.....	10-75
Table 10-14:	Accessories: connection modules.....	10-76
Table 10-15:	Accessories: Extensions for connection modules.....	10-77
Table 10-16:	Accessories: Cables and connector covers for CLV490 without heater	10-79
Table 10-17:	Accessories: Cables and connector covers for CLV490 with heater.....	10-81
Table 10-18:	Accessories: plug-in connections	10-82
Table 10-19:	Accessories: incremental encoder.....	10-82
Table 10-20:	Supplementary documentation	10-85

Figures

Fig. 2-1:	Laser warning labels on the CLV490	2-3
Fig. 3-1:	Design of the CLV490	3-5
Fig. 3-2:	Block diagram: CLV490 functions.....	3-6
Fig. 3-3:	Optimization of the depth of field for the object	3-7
Fig. 3-4:	Dynamic focus control: classification of the reading range in distance configurations.....	3-8
Fig. 3-5:	Reading modes of the CLV490 in stand-alone configuration.....	3-9
Fig. 3-6:	LEDs.....	3-11
Fig. 4-1:	Line scanner: replacing the laser warning labels.....	4-2
Fig. 4-2:	Line scanner: position of the securing threads on the CLV490	4-3
Fig. 4-3:	Line scanner: Mounting possibilities of the CLV490.....	4-3
Fig. 4-4:	Scanning methods: alignment with bar code and conveyor direction.....	4-4
Fig. 4-5:	Definition of the reading distance "a" and of the aperture angle a.....	4-4
Fig. 4-6:	Line scanner: Reading angle between the scan line and the bar code.....	4-5
Fig. 4-7:	Avoiding surface reflections: Angle between the emitted light and the bar code (tilted away from the vertical axis)	4-5
Fig. 4-8:	Count direction of the reading angle RA in the scan line and of the code angle CW for the oscillating mirror	4-6
Fig. 4-9:	Line scanner: scan line in Adjusting mode.....	4-10
Fig. 4-10:	Line scanner: mounting example for the external reading pulse sensor	4-11
Fig. 4-11:	Mounting example for object distance detection.....	4-13
Fig. 5-1:	Block diagram: Connection of the CLV490 to the CDB420 connection module.....	5-3
Fig. 5-2:	Block diagram: Connection of the CLV490 to the CDM490 connection module.....	5-5
Fig. 5-3:	Connecting the host interface.....	5-20
Fig. 5-4:	Connecting the auxiliary interface.....	5-21
Fig. 5-5:	Connections of the "Sensor" switching input.....	5-22
Fig. 5-6:	Connections of the "IN 0" to "IN 4" switching inputs	5-23
Fig. 5-7:	Connections of the "Result 1" to "Result 4" switching outputs.....	5-26
Fig. 6-1:	Bar code pattern (Code 39; module width 0.35 mm (11.8 mil); Print ratio 2:1)	6-4
Fig. 6-2:	Narrowing the reading space using limit values.....	6-10
Fig. 6-3:	Narrowing the autofocus range using limit values	6-15
Fig. 6-4:	Oscillating mirror: "Oscillating with fixed amplitude" mode	6-18
Fig. 6-5:	Oscillating mirror: "Oscillating with variable amplitude" mode.....	6-19
Fig. 6-6:	One-Shot: Object tracking (bar code read from front).....	6-20
Fig. 6-7:	CLV-Setup: Displaying the reading result of the terminal interface in the Terminal Emulator	6-39
Fig. 6-8:	Reading result of the auxiliary interface: structure for "Good Read"	6-40
Fig. 6-9:	Reading result of the auxiliary interface: structure for "No Read"	6-40
Fig. 6-10:	CLV-Setup: Displaying the percentage evaluation in the Terminal Emulator	6-42
Fig. 6-11:	CLV-Setup: Dialog window for running the background teach-in.....	6-44
Fig. 6-12:	CLV-Setup: Display of the learned background.....	6-45
Fig. 6-13:	Appearance of scan line in the "Show RA-limits" mode	6-46
Fig. 6-14:	CLV-Setup: Example of output in the "Background Analysis" dialog box.....	6-47
Fig. 6-15:	CLV-Setup: Selection of the signals to be displayed in I/O Monitoring.....	6-49
Fig. 6-16:	CLV-Setup: Example of output in the "I/O Monitoring" dialog box.....	6-50
Fig. 6-17:	CLV-Setup: "Operating Data" dialog box.....	6-53
Fig. 6-18:	CLV-Setup: Displaying the reading result of the host interface in the Terminal Emulator with direction identifier at the beginning (in this case: O = Output)	6-55
Fig. 6-19:	CLV-Setup: Displaying the self-test result in the Terminal Emulator	6-57
Fig. 7-1:	Cleaning the reading window.....	7-2
Fig. 7-2:	Cleaning the external optical sensors (reading pulse generator,	

object-height detector) 7-2

Fig. 9-1: Dimensions of the CLV490 line scanner, front reading window 9-4

Fig. 9-2: Dimensions of the CLV490: line scanner with oscillating mirror, side reading window 9-5

Fig. 10-1: CLV490-0010/-0011 (Standard density): Reading field height as a function of the reading distance and resolution 10-3

Fig. 10-2: CLV490-0010/-0011 (Standard density): Min. and Max. reading distance (measured radially) as a function of the focus position at a resolution of 0.35 mm (13.8 mil) and an aperture angle of $\alpha = 40^\circ$ 10-4

Fig. 10-3: CLV490-0010/-0011 (Standard density): Min. and Max. reading distance (measured radially) as a function of the focus position at a resolution of 0.35 mm (13.8 mil) and an aperture angle of $\alpha = 56^\circ$ 10-5

Fig. 10-4: CLV490-0010/-0011 (Standard density): Min. and Max. reading distance (measured radially) as a function of the focus position at a resolution of 0.50 mm (19.7 mil) and an aperture angle of $\alpha = 40^\circ$ 10-6

Fig. 10-5: CLV490-0010/-0011 (Standard density): Min. and Max. reading distance (measured radially) as a function of the focus position at a resolution of 0.50 mm (19.7 mil) and an aperture angle of $\alpha = 56^\circ$ 10-7

Fig. 10-6: Characteristics field CLV490-0010/-0011 (Standard density): Scanning frequency as a function of the radial reading distance and resolution 10-8

Fig. 10-7: CLV490-1010/-1011 (Standard density): Reading field height as a function of the reading distance and resolution 10-9

Fig. 10-8: CLV490-1010/-1011 (Standard density): Min. and Max. reading distance (measured radially) as a function of the focus position at a resolution of 0.35 mm (13.8 mil) and an aperture angle of $\alpha = 40^\circ$ 10-10

Fig. 10-9: CLV490-1010/-1011 (Standard density): Min. and Max. reading distance (measured radially) as a function of the focus position at a resolution of 0.35 mm (13.8 mil) and an aperture angle of $\alpha = 50^\circ$ 10-11

Fig. 10-10: CLV490-1010/-1011 (Standard density): Min. and Max. reading distance (measured radially) as a function of the focus position at a resolution of 0.50 mm (19.7 mil) and an aperture angle of $\alpha = 40^\circ$ 10-12

Fig. 10-11: CLV490-1010/-1011 (Standard density): Min. and Max. reading distance (measured radially) as a function of the focus position at a resolution of 0.50 mm (19.7 mil) and an aperture angle of $\alpha = 50^\circ$ 10-13

Fig. 10-12: Characteristics field CLV490-1010/-1011 (Standard density): Scanning frequency as a function of the radial reading distance and resolution 10-14

Fig. 10-13: CLV490-1010/-1011 (Standard density): deflection range as a function of radial reading distance, deflection angle and resolution 10-15

Fig. 10-14: CLV490-2010/-2011 (High density): Reading field height as a function of the reading distance and resolution 10-16

Fig. 10-15: CLV490-2010/-2011 (High density): Min. and Max. reading distance (measured radially) as a function of the focus position at a resolution of 0.25 mm (9.8 mil) and an aperture angle of $\alpha = 40^\circ$ 10-17

Fig. 10-16: CLV490-2010/-2011 (High density): Min. and Max. reading distance (measured radially) as a function of the focus position at a resolution of 0.35 mm (13.8 mil) and an aperture angle of $\alpha = 40^\circ$ 10-18

Fig. 10-17: CLV490-2010/-2011 (High density): Min. and Max. reading distance (measured radially) as a function of the focus position at a resolution of 0.35 mm (13.8 mil) and an aperture angle of $\alpha = 56^\circ$ 10-19

Fig. 10-18: Characteristics field CLV490-2010/-2011 (High density): Scanning frequency as a function of the radial reading distance and resolution 10-20

Fig. 10-19: CLV490-3010/-3011 (High density): Reading field height as a function of the reading distance and resolution 10-21

Fig. 10-20: CLV490-3010/-3011: (High density) Min. and Max. reading distance (measured radially) as a function of the focus position at a resolution of 0.25 mm (9.8 mil) and an aperture angle of $\alpha = 40^\circ$ 10-22

Fig. 10-21: CLV490-3010/-3011 (High density): Min. and Max. reading distance (measured radially) as a function of the focus position at a resolution of 0.35 mm (13.8 mil) and an aperture angle of $\alpha = 40^\circ$ 10-23

Fig. 10-22: CLV490-3010/-3011 (High density): Min. and Max. reading distance (measured radially) as a function of the focus position at a resolution of 0.35 mm (13.8 mil) and an aperture angle of $\alpha = 50^\circ$ 10-24

Fig. 10-23: Characteristics field CLV490-3010/-3011 (High density): Scanning frequency as a function of the radial reading distance and resolution..... 10-25

Fig. 10-24: CLV490-3010/-3011 (High density): Deflection range as a function of radial reading distance, deflection angle and resolution 10-26

Fig. 10-25: CLV490-6010/-6011 (Low density): Reading field height as a function of the reading distance and the tilt at a resolution of 0.5 mm (19.7 mil). 10-27

Fig. 10-26: CLV490-6010/-6011 (Low density): Min. and Max. reading distance (measured radially) as a function of the focus position at a resolution of 0.5 mm (19.7 mil) and an aperture angle of $\alpha = 40^\circ$ 10-28

Fig. 10-27: CLV490-6010/-6011 (Low density): Min. and Max. reading distance (measured radially) as a function of the focus position at a resolution of 0.5 mm (19.7 mil) and an aperture angle of $\alpha = 60^\circ$ 10-29

Fig. 10-28: Characteristics field CLV490-6010/-6011 (Low density): Scanning frequency as a function of the radial reading distance and resolution..... 10-30

Fig. 10-29: CLV490-7010/-7011 (Low density): Reading field height as a function of the reading distance and tilt at a resolution of 0.5 mm (19.7 mil)..... 10-31

Fig. 10-30: Characteristics field CLV490-7010/-7011 (Low density): Scanning frequency as a function of the radial reading distance and resolution..... 10-32

Fig. 10-31: CLV490-7010/-7011 (Low density): Deflection range as a function of radial reading distance, deflection angle and tilt at a resolution of 0.5 mm (19.7 mil) 10-33

Fig. 10-32: External parameter memory, installed on the CLV490 10-34

Fig. 10-33: CLV-Setup: "Device configuration" tab with the CLV490 start options 10-36

Fig. 10-34: CLV-Setup: dialog box for adjusting the external parameter memory 10-38

Fig. 10-35: CLV490 with heater: temperature curve inside the housing..... 10-40

Fig. 10-36: CLV-Setup: Result display of the AutoBaud Detect function..... 10-47

Fig. 10-37: User interface of the "CLV-Setup" software 10-48

Fig. 10-38: CLV-Setup: entering commands in the Terminal Emulator 10-53

Fig. 10-39: Line scanner: calculating the number of scans for ladder-type bar code arrangements..... 10-55

Fig. 10-40: Line scanner: calculating the number of scans for fence-type bar code arrangements..... 10-55

Fig. 10-41: Line scanner with oscillating mirror: calculating the number of scans for fence-type bar code positioning..... 10-56

Fig. 10-42: One-Shot: Line scanner with oscillating mirror: calculating the number of scans for fence-type bar code positioning..... 10-57

Fig. 10-43: Required distance between the bar codes on an object..... 10-58

Fig. 10-44: Parameterization example: prepare a sketch of the reading situation 10-61

Fig. 10-45: Parameterization example: settings on the "Reading Configuration" tab . 10-62

Fig. 10-46: Parameterization example: "Autofocus Parameters" tab..... 10-63

Fig. 10-47: Parameterization example: "Autofocus Limits" tab 10-63

Fig. 10-48: Parameterization example: "Autofocus Optimizations" tab 10-64

Fig. 10-49: Parameterization example: Buttons on the "Device Configuration" tab.... 10-65

Fig. 10-50: Parameterization example: "Scanner Position Parameters" tab 10-65

Fig. 10-51: Parameterization example: Settings on the "Device Configuration" tab ... 10-66

Fig. 10-52: Parameterization example: settings on the "Code Configuration" tab..... 10-67

Fig. 10-53: Parameterization example: "2/5 Interleaved" tab 10-67

Fig. 10-54: Parameterization example: "Host interface" tab (default setting) 10-68

Fig. 10-55: Parameterization example: "Data Strings" tab (default setting) 10-68

Fig. 10-56: Auxiliary input via the auxiliary interface of the CLV490 10-69

Fig. 10-57: CLV-Setup: auxiliary input via the Terminal Emulator	10-70
Fig. 10-58: Dimensions of the angle bracket, single No. 2013824.....	10-83
Fig. 10-59: Dimensions of the articulated bracket No. 2018435	10-83
Fig. 10-60: Front view of quick clamping device No. 2016110 with angle braket No. 2013824	10-83
Fig. 10-61: Dimensions of the hinge bracket, No. 2022996.....	10-84
Fig. 10-62: Dimensions of the mirror hood, No. 2032070	10-84
Fig. 10-63: Copy of the Declaration of Conformity (Page 1, scaled down).....	10-94
Fig. 10-64: Scannable bar codes with various module widths (print ratio 2:1)	10-101

1 Notes on this document

1.1 Purpose

This document is a guide to the operation of the bar code scanner

- CLV490 with auto-focus

in the following variations:

- Line scanner
 - CLV490-2010, resolution from 0.20 mm (7.9 mil) (high density)
 - CLV490-2011, resolution from 0.20 mm (7.9 mil) (high density), with heater
 - CLV490-0010, resolution from 0.30 mm (11.8 mil) (standard density)
 - CLV490-0011, resolution from 0.30 mm (11.8 mil) (standard density), with heater
 - CLV490-6010, resolution from 0.40 mm (15.7 mil) (low density)
 - CLV490-6011, resolution from 0.40 mm (15.7 mil) (low density), with heater
- Line scanner with oscillating mirror
 - CLV490-3010, resolution from 0.20 mm (7.9 mil) (high density)
 - CLV490-3011, resolution from 0.20 mm (7.9 mil) (high density), with heater
 - CLV490-1010, resolution from 0.30 mm (11.8 mil) (standard density)
 - CLV490-1011, resolution from 0.30 mm (11.8 mil) (standard density), with heater
 - CLV490-7010, resolution from 0.40 mm (15.7 mil) (low density)
 - CLV490-7011, resolution from 0.40 mm (15.7 mil) (low density), with heater

This document provides information on

- Mounting and connecting the device
- Startup
- Operating and configuring (parametrizing) the device
- Maintenance
- Exchanging the device without losing the parameter set
- Special applications and procedures

The bar code scanner with all its variants will in this manual be referred to as the "CLV490", except where a distinction is necessary.

1.2 Target audience

This document is intended for persons who are responsible for the following activities:

1.2.1 Mounting, electrical installation, maintenance and replacement

Electricians and service technicians.

1.2.2 Startup, operation and configuration

Technicians and engineers.

1.3 Information content

This document contains all the information required to mount, install, and start up the CLV490 with the **factory settings**.

A series of step-by-step instructions is provided for each of these activities.

Configuration of the CLV490 for **the application-specific reading situations** is carried out with the Windows-oriented PC software "CLV-Setup". Further assistance is also available in the form of the online help system CLV-Setup Help. The procedure for installing and operating the software is described in the appendix.

For further information on the design of the bar code scanner or on bar code technology in general, please contact the Division Auto Ident at SICK AG.

Internet address: **www.sick.com**.

1.4 Symbols

Some of the information in this document is marked specially so that you can access it quickly:



Warning

Warnings are provided to prevent injury to operating personal or serious damage to the bar code scanner.

- Always read warnings carefully and observe them at all times.

Reference Italics are used to refer to more detailed information elsewhere.

Note Indicates special features or characteristics.

Explanation Explanations provide background information on technical features.

Recommendation Recommendations help you carry out certain procedures more effectively.

Tip Tips explain settings in the user interface of the "CLV-Setup" program.

Default Marks a section containing the factory defaults.

SCANNING FREQUENCY This typeface is used to refer to a term in the "CLV-Setup" program.



Icons refer to buttons in the "CLV-Setup" program.

"Host receive fault" This typeface is used for messages output via the auxiliary interface of the CLV490.



This symbol is used to mark sections that describe steps carried out with the "CLV-Setup" program.



This symbol refers to additional technical documentation.

- There is a procedure which needs to be carried out. This symbol indicates operational instructions which only contain one operational step or operational steps in warning notices which do not have to be followed in any particular order. Operational instructions comprising several steps are denoted using consecutive numbers.

- ⇒ Here you select a function of the "CLV-Setup" user interface.

2 Safety information

2.1 Authorized users

For the CLV490 to function correctly and safely, it must be mounted and operated by sufficiently qualified personnel.

Repairs to the CLV490 should only be carried out by qualified and authorized SICK AG service staff.

The end user must be supplied with the operating instructions.

The end user must be provided with expert tuition and is advised to read the operating instructions.

The following qualifications are required for the various tasks involved:

2.1.1 Mounting and maintenance

- General technical training
- Knowledge of the standard guidelines relating to safety at the workplace

2.1.2 Electrical installation and replacement

- Practical training in electrical engineering
- Knowledge of the standard safety guidelines relating to electrical engineering
- Experience operating the devices in the relevant application (e. g. conveyor belt)

2.1.3 Startup, operation and configuration

- Experience operating the devices in the relevant application (e. g. conveyor belt)
- Knowledge of the hardware and software environment of the relevant application (e. g. conveyor belt)
- Basic understanding of Windows 95™/98™, Windows NT4.0™, Windows 2000™ or Windows XP™
- Ability to use an HTML browser (e. g. Internet Explorer™)
- Basic understanding of data transfer methods
- Basic understanding of bar code technology

2.2 Intended use

The CLV490 is designed to detect and decode bar codes automatically. It is mounted in a reading station and reads bar codes on objects positioned on a conveyor belt, for example.

In stand-alone configuration the CLV490 transfers the data content of the decoded bar codes via its host interface to a host computer for further processing. Being integrated in the OTS400 Omni Tracking System together with other CLV490, the CLV490 transfers the read results via its CAN interface to the OTC400 Omni Tracking Controller.

Note Any warranty claims against SICK AG shall be deemed invalid in the case of other system use or system modifications, this includes modifications during installation and electrical installation, changes to the SICK software, or opening the device.

2.3 General safety instructions and protection measures

- Always read the general safety instructions carefully and observe them at all times. Please also observe the warnings in front of the operating instructions in each chapter of this document.



Risk of injury by electrical current

In the CDM490 Connection Module, the optional CMP490 Power Supply Module is connected to a mains voltage of 100 to 250 V AC/ 50 to 60 Hz.

- When working with electrical equipment, always follow the relevant safety specifications.



Laser beam can cause blindness.

The CLV490 uses a class 2 red-light laser. Looking directly at the laser beam can seriously damage your eyesight.

The entire glass window acts as a laser outlet aperture.

Caution – use of controls or adjustments or performance of procedures other than those specified herein may result in hazardous radiation exposure.

- As with sunlight, never look directly into the laser beam.
- Do not direct the laser beam at other persons.
- Mount and align the CLV490 in such a way to prevent the laser beam reflecting off mirrored surfaces.
- Do not open the housing.
(Opening the housing does not deactivate the laser diode).
- Observe the laser protection specifications (latest version)

Laser power

The laser operates at a wave length of $\lambda = 650 \text{ nm}$ (visible red light). The power output at the reading window is max. 2.8 mW. The emitted radiation is not dangerous to human skin. The product is classified in laser class 2 (laser class II) in accordance with EN 60825-1, IEC 60825-1, and 21 CFR 1040.10 (for publication date, see the warning sign on the device).

Note No maintenance required to keep this product in compliance with laser class II.

Laser warnings

The laser warning symbols (*Fig. 2-1*) can be found on the CLV490 at the following locations:

- The laser warning symbol on line scanners is positioned beside the reading window on the front side of the device. The laser warning in GB English/US English is located on the side containing the electrical connections (see *Fig. 3-1, Page 3-5*.)
The additional laser warnings in English applicable to the USA are positioned beside the reading window on the front side of the device and at the bottom of the device.
- The laser warning symbol on line scanners with oscillating mirror is located above the reading window, on the cover of the mirror. The laser warning in GB English/US English is located on the side containing the electrical connections.
The additional laser warnings in English applicable to the USA are positioned below the reading window on the front side of the device and at the bottom of the front side.

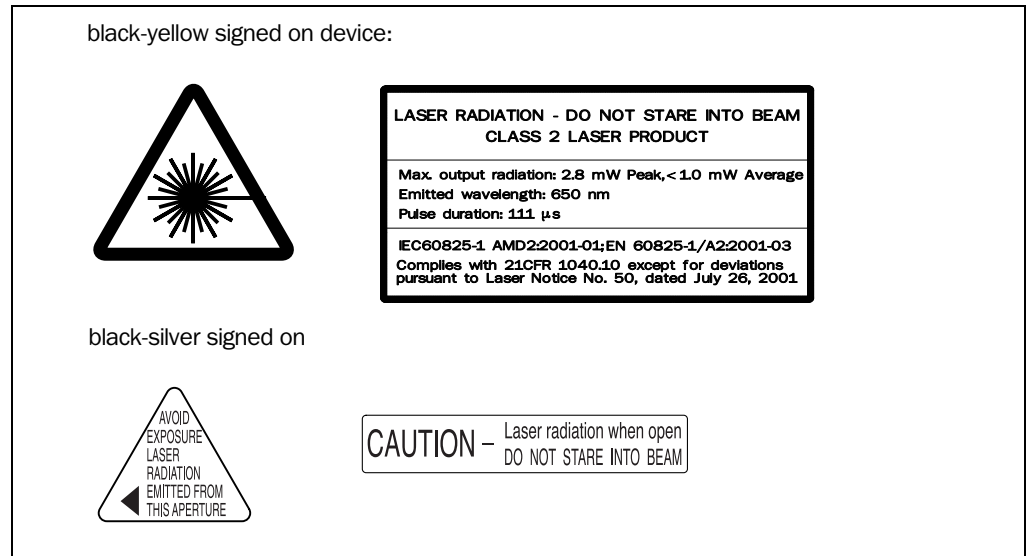

Fig. 2-1: Laser warning labels on the CLV490

Note A set of laser warnings in German/US English and French/US English is included in the delivery scope. The GB English/US English warnings can be pasted over with these if necessary.

If the CLV490 is installed in a machine/panel with the result that the laser warning labels are no longer visible, additional warnings in the same language(not included in the scope of delivery) must be provided on the machine beside the emergence aperture of the laser beam.

Internal protective circuits

The CLV490 is equipped with monitoring circuits that deactivate the laser diode in the event of a malfunction.

Activation and deactivation of the laser diode is controlled by the reading pulse (trigger source).

A timer (laser timeout) automatically deactivates the laser diode in Reading mode ("Sensor input" and "Serial interface" trigger mode) if the reading interval has not ended after 10 minutes (default setting). However, it does not end the reading interval. In this case, the CLV490 outputs the message:

"Laser safety timeout"

on the auxiliary interface. The reading interval must be terminated by resetting the trigger signal. The laser diode is activated again by the next reading trigger.

The laser timeout can be set in the range of 1 min to 25 h or deactivated (see [Table 6-23, Page 6-36](#)).

In the "Percentage Evaluation" mode, "Adjusting" mode and "Show RA-limits" mode as well as in the pulse mode "Free-running", in reading mode, the laser diode is constantly activated. In the pulse mode "Object Polling" the laser diode is activated due to the parameterized search/pause ratio. In the "Background Analysis" function the laser diode is constantly pulsed.

Note In the Reading mode, the CLV490 carries out a measurement referencing at regular intervals. During referencing, it turns the laser diode on for a maximum of 10 seconds.

2.4 Quick stop and quick restart

2.4.1 Stopping the CLV490

- Switch off the power supply or remove the cables of the CLV490 from the connection module.

This can result in loss of the following (at the most):

- The application-specific parameter set, if it was stored **temporarily** in the CLV490
- The last reading result
- Daily operating data
(operating hours counter, number of reading intervals, Good Read count, No Read count, maximum duration trigger, minimum duration trigger, matchcode 1 count, matchcode 2 count, no match count)

2.4.2 Restarting the CLV490

- Switch on the power supply or reattach the cables of the CLV490 to the connection module.
The CLV490 resumes operation with the parameter set that was **last stored permanently** and reset the daily operating data.

2.5 Environmental information

The CLV490 is designed to cause minimum impact on the environment. It does not contain any silicone-based materials on the housing surface and, therefore, does not represent any problems for paint sprayers in paint shops, for example.

2.5.1 Power requirements

The power requirements depend on the variants:

- The line scanner has a typical power consumption of 11 W and max. 16 W
- The line scanner with oscillating mirror has a typical power consumption of 13 W and max. 18 W
- The line scanner equipped with an integrated heater has a typical power consumption of 75 W and max. 90 W
- The line scanner with oscillating mirror equipped with an integrated heater has a typical power consumption of 75 W and max. 100 W

The values are given for devices with disconnected switching outputs.

2.5.2 Disposal after removal from service

Always dispose irreparable devices in a manner that is not harmful to the environment and in accordance with the applicable national waste disposal regulations. The CLV490 can be separated into recyclable secondary raw materials and special-category waste (electronic scrap).

See also [Chapter 7.4 Disposal, Page 7-3](#).

SICK AG currently does not accept delivery of unusable or irreparable devices.

3 Product description

3.1 Design

3.1.1 Scope of delivery

The CLV490 is supplied with the following in the **packing**:

- An information sheet (note on device) with terminal diagram and Quick Start instructions
- An additional set of Class 2 laser warning labels (self-adhesive) in German/US English and French/US English

Depending on the **number of devices ordered**, one or more copies of the following:

- CD-ROM (no. 2029112) with
 - "CLV-Setup" program for Windows™ and the "CLV-Setup Help" online help system (HTML files)
 - "CLV Connect" PC software (HTML files showing terminal diagrams)
 - CLV490 Operating Instructions in English and German as PDF edition as well as additional publications (connections module, other SICK bar code scanners)
 - freely available "Acrobat Reader" PC software for reading PDF files

Note The latest versions of all the current publications/programs on the CD-ROM can also be downloaded from **www.sick.com**.

Depending on the number of **copies ordered**, the delivery includes (**optional**):

- CLV490 Operating Instructions in English and/or German (printed edition)

Chapter 10.13 Ordering Information, Page 10-75 contains an overview of the available mounting accessories, (bus) connection modules, external parameter memories, cables, connectors, and incremental encoder as well as sensors for generating the reading pulse.

3.1.2 Variants

The CLV490 is currently available in the following variants:

	Type (red light)	Part. no.	Scanning method	Resolution	Reading window	Heater
High density	CLV490-2010	1019311	Line scanner	From 0.2 mm (7.9 mil)	End	No
	CLV490-3010	1019313	Line scanner with oscillating mirror	From 0.2 mm (7.9 mil)	Side	No
	CLV490-2011	1019312	Line scanner	From 0.2 mm (7.9 mil)	End	Yes
	CLV490-3011	1019314	Line scanner with oscillating mirror	From 0.2 mm (7.9 mil)	Side	Yes
Standard	CLV490-0010	1016958	Line scanner	From 0.3 mm (11.8 mil)	End	No
	CLV490-1010	1016959	Line scanner with oscillating mirror	From 0.3 mm (11.8 mil)	Side	Yo
	CLV490-0011	1016960	Line scanner	From 0,3 mm (11.8 mil)	End	Yes
	CLV490-1011	1016961	Line scanner with oscillating mirror	From 0.3 mm (11.8 mil)	Side	Yes
Low density	CLV490-6010	1018872	Line scanner	From 0.4 mm (15.7 mil)	End	No
	CLV490-7010	1019094	Line scanner with oscillating mirror	From 0.4 mm (15.7 mil)	Side	No
	CLV490-6011	1019095	Line scanner	From 0.4 mm (15.7 mil)	End	Yes
	CLV490-7011	1019096	Line scanner with oscillating mirror	From 0.4 mm (15.7 mil)	Side	Yes

Table 3-1: CLV490 variants

3.1.3 System requirements for stand-alone configuration

CLV490 without heater The following are required to start up and operate the CLV490 without heater:

1. A SICK Connection Module to provide the power supply of the CLV490 (**18 to 30 V DC**) and connect the data and function interfaces. Available types:
 - CDB420-001 (no. 1023885) for 10 to 30 V DC, enclosure rating max. IP 65
 - CDB420-101 (no. 1024305) for 10 to 30 V DC, enclosure rating max. IP 65
 - CDM490-0001 (no. 1025363) for 10 to 30 V DC, enclosure rating max. IP 65

– or –

Alternatively, a non-SICK Power pack with a voltage output of **18 to 30 V DC** (functional extra-low voltage pursuant to IEC 364-4-41) and a minimum power output of **20 W**.
Cable no. 2020264 (3 m (9.84 ft)) with 15-pin D Sub HD connector and one open end for connecting the CLV490 to the non-SICK Power pack (supply voltage).
2. The following operating voltages/power output values:
 - CDB420-001: **18** to 30 V DC (to IEC 364-4-41), min. 20 W
 - CDM490-0001: **18** to 30 V DC (to IEC 364-4-41), min. 40 W, when using the CMP490 Power Supply Module: 100 to 250 V AC, 50 to 60 Hz
 - If the following modules are additionally built-in in the **CDB420**:
CMC400 (Conenction Module Cloning): **18** to 30 V DC, additionally 0.5 W
 - If the following modules are additionally built-in in the **CDM490**:
CMC400 (Connection Module Cloning): **18** to 30 V DC, additionally 0.5 W
CMD400 (Connection Module Display): **18** to 30 V DC, additionally 1 W
CMF400 (Connection Module Fieldbus): **18** to 30 V DC, additionally 2 W
3. Fitting cables see [Chapter 5.2.2 Prefabricated cables \(overview\), Page 5-2](#).
4. With external clock pulse (start/stop) supply via the "Sensor" switching input: a suitable reading pulse sensor for signaling an object with a bar code, e. g. a photoelectric reflex switch.
5. With extended external clock pulse (stop) via the "IN 4" switching input: a suitable reading pulse sensor for signaling the end of an object, e. g. a photoelectric reflex switch.
6. With object distance detection via the "IN 0" to "IN 4" switching inputs: suitable sensors for multi-stage dynamic focus control, e. g. photoelectric reflex switches.
7. With internal object tracking: a suitable incremental encoder, e. g. no. 2022714.
8. To separate bar codes with the same name (same code type, identical data content): a suitable incremental encoder (s. above).
9. A higher-level computer (host) with a data interface of type RS 422/485 or RS 232.
10. A PC (min. Pentium II, 350 MHz, 64 MB RAM, CD drive, a serial port (COM x), mouse (recommended)) with Windows 95™/98™, Windows NT™, Windows 2000™ or Windows XP™.
11. A 3-core RS 232 data cable (null modem cable) with two 9-pin D Sub sockets for connecting the PC to the auxiliary interface of the CLV490 in the connection module, e. g. no. 2014054. Pin 2 (RxD) and Pin 3 (TxD) are crossed.
12. An HTML browser, e. g. Internet Explorer™, for using the online help system CLV-Setup Help.
13. To connect the CLV490 to Profibus DP, to Device Net or to Ethernet TCP/IP: the appropriate CMF400 Connection Module Fieldbus for building-in in the CDM490 Connection Module.

14. For connection of the CLV490 to the CAN Scanner Network: the Operating Instructions "Application of the CAN interface" (no. 8009180, English edition).

CLV490 with heater The following are required to start up and operate the CLV490 with heater:

1. A SICK Connection Module to provide the power supply for the CLV490 (**24 V DC +20 %/-10 %**) and connect the data and function interfaces. Available types:
 - CDM490-0001 (no. 1025363) for 10 to 30 V DC, enclosure rating max. IP 65
 - or –

Alternatively, a non-SICK Power pack with a voltage output of 24 V DC +20 %/-10 % (functional extra-low voltage pursuant to IEC 364-4-41) and a minimum power output of **100 W**.

Cable no. 2020264 (3 m (9.84 ft)) with 15-pin D Sub HD connector and one open end for connecting the CLV490 to the non-SICK Power pack (supply voltage).

2. The following operating voltages/power output values:
 - CDM490-0001: 24 V DC +20 %/-10 % (pursuant to IEC 364-4-41), min. 100 W

Note The CMP490 Power Supply Module (output max. 25 W) is not suitable to provide the power supply for the CLV490 with heater.

3. See pos. 3 under **CLV490 without heater**

3.1.4 Product features and functions (overview)

High-performance laser scanner:

- Line scanner (front-end reading window)
- Scanner variant with oscillating mirror (side reading window)
- Resolution variants: standard density, high density, low density
- Dynamic focus or autofocus
- Alternatively dynamic focus control with external or internal trigger
- Reading range 500 to 2,100 mm (19.7 to 82.7 in) (line scanner, standard density)
- Resolution 0.25 to 1.0 mm (9.8 to 39.4 mil) (standard density)
- Scanning/decoding frequency 600 to 1,200 Hz
- Reading range can strongly be limited (3-dimensional reading space)

Safety and user-friendly features:

- Robust, compact metal housing, max. IP 65, CE certification
- Laser class 2, laser diode switches off if reading interval is active for too long and if the output power is exceeded
- Automatic self-test on startup. Can also be triggered at any time
- Diagnosis tools for installing and monitoring the system
- Parameterized output of reading diagnosis data in reading mode
- Operating data query, and error messages
- Test string function for signaling readiness for operation
- Future proof thanks to firmware update via serial interface (flash PROM)
- Low power consumption, other voltage range

Easy operation/configuration:

- With "CLV-Setup" PC software for Windows
- Alternatively with simple command strings, also for use with special devices

- Four status LEDs
- External parameter memory (optional) simplifies device replacement

Operating modes:

- Reading mode
- Percentage evaluation - for assessing the quality of the reads
- Special functions for system installation

Bar code evaluation:

- All standard bar code types
- Max. 50 codes per reading pulse, max. 12 per scan
- Code comparison (max. 5 matchcodes), can also be used as filter or sort criterion for the reading result
- Sort sequences: reading angle, FIFO, LIFO, code length list, matchcodes

Reading pulse (start/stop mode):

- External reading pulse, via switching input(s) or serial interface
- Timer (scanner with oscillating mirror: also oscillating extrema)
- Free running
- Object polling for on object per reading interval

Object Tracking (Tracking mode):

- Internal object tracking for max. 10 objects per reading interval
- Extended object tracking (20 objects) in combination with OTS400 Object Tracking System

Electrical interfaces:

- Serial host interface (RS 422/485 or RS 232) with variable transfer rate and telegram structure
- Serial auxiliary interface (RS 232) as auxiliary data interface with special diagnosis and statistics functions
- CAN interface for integration in the SICK CAN Scanner Network or a CANopen network, and for OTS operation
- 6 switching inputs for external reading pulse, focus control, encoder increment and special function (teach-in)
- 4 switching outputs for signaling defined events in reading mode

Connections:

- All interfaces are connected via two 15-pin D Sub HD connections on the housing
- CDB420 or CDM490 Connection Module for connection to host and for integration in SICK CAN Scanner Network
- CMF400 Connection Module Fieldbus in the CDM490 for connection to field bus systems

Additional functions:

- Version with integrated heater (max. -35 °C (-31 °F))
- External parameter memory in connector cover (optional)

3.1.5 Design

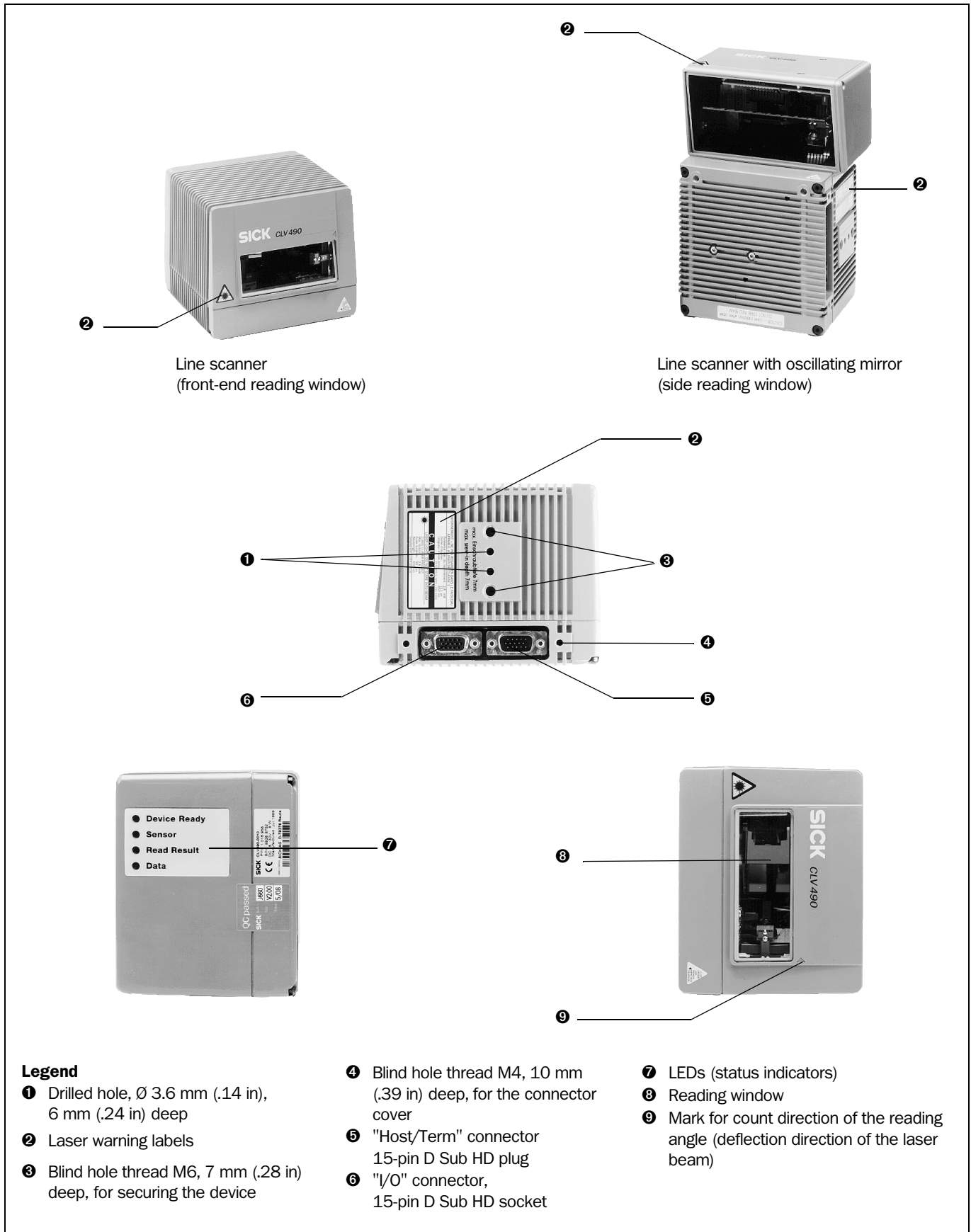

Fig. 3-1: Design of the CLV490

3.2 Method of operation

The CLV490 first scans the bar code with a scan line and then decodes it. In stand-alone configuration, the data is forwarded via the serial host interface (main data interface) to a host/PC for further processing, or via the CAN interface to the OTS400 Omni Tracking System. An overview of the CLV490 functions is provided in [Fig. 3-2](#).

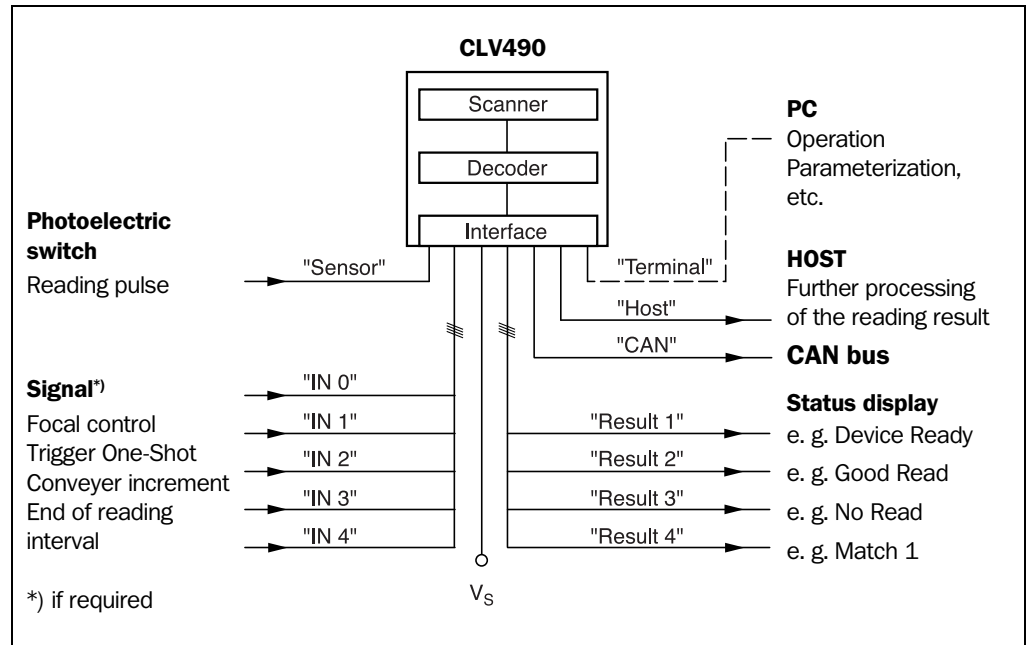

Fig. 3-2: Block diagram: CLV490 functions

The CLV490 is equipped with two decoders:

- The SMART decoder (**SICK Modular Advanced Recognition Technology**) for decoding bar codes with small code height, bar codes that are dirty or damaged, as well as bar codes that are tilted excessively (azimuth angle)
- The tried-and-tested standard decoder of the CLV series

The CLV490 derives useful diagnosis data from the reading process and can transfer it to also the host. It also records operating data that can be interrogated at any time. The quality of the read can be checked in percentage evaluation mode.

To start the reading process when an object is located in the reading field, the CLV490 requires a suitable trigger. This opens an internal time window ("reading interval") in the CLV490. In the default configuration, this trigger is supplied by an external reading pulse sensor. Alternative trigger sources include Free-running mode or a command via the host interface (for more complex applications: object polling or OTS trigger).

The current operating status is indicated by four LEDs.

If the trigger is supplied externally, the "Sensor" switching input instructs the CLV490 to start the reading process. The five "IN 0" to "IN 4" switching inputs switch the focus position in response to certain events, as an alternative to the autofocus function. The "IN 3" and "IN 4" inputs can also be assigned special functions. The four "Result 1" to "Result 4" switching outputs can be assigned to different functions for displaying the result status and also control external devices, such as a PLC.

The CLV490 is operated and configured via the serial auxiliary interface (auxiliary interface) using the "CLV-Setup" software or via the host interface/auxiliary interface using command strings.

System and error messages help you to configure the device and to locate the source of errors during startup and reading mode.

3.2.1 Autofocus function

The autofocus function enables the CLV490 to detect the distance of an object without the need for external sensors and adjusts the focus position automatically. In order to do so, the CLV490 measures the object distance in its reading field in front of the reading window and internally creates a distance profile. Following this, it positions the focus on the object.

3 operating modes are provided for various applications:

- *Minimum distance*: the CLV490 focuses on the minimum distance in the distance profile and ignores the background in the reading field. Application: with unobstructed view of the object without any surrounding objects protruding into the reading plane. One object with bar code(s) only is inside the reading field during one reading pulse.
- *Differential background*: the distance profile of the reading field background is programmed (teach-in) in the CLV490 without any objects present. The CLV490 focuses on the object which it recognizes by comparing the object with the background. Application: with unobstructed view of the object restricted by other objects that protrude constantly into the reading plane. One object with barcode(s) only is inside the reading field during one reading pulse.
- *Differential background and tracking*: if several objects with different distances to the CLV490 are positioned in the reading field at the same time (distance conflict), the CLV490 focuses on the object that is nearest to but has not exceed its internal focus switchover point. Application: in OTS operation (applications with internal tracking or tracking by the OTC400 Omni Tracking Controller).

The distance profile of the background can also be displayed in the "CLV-Setup" program. The autofocus range is defined by the aperture angle, the autofocus space, and (in the case of line scanners with oscillating mirror) also by the angle of deflection. The park setting of the focus position, from which the device focuses for each read, can be specified in addition to a time and/or position-related delay (timeout or hysteresis). If necessary, an offset can be defined for the focus position to be set by the measurement. The depth of field, which radiates in the direction of the scan lines and is caused by the V-principle of the beam deflection, is optimized as a result (Fig. 3-3).

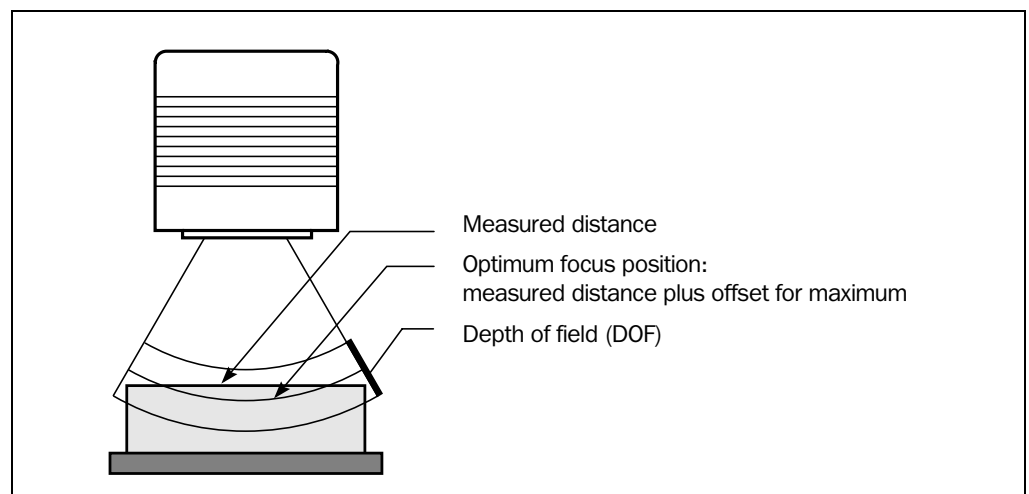

Fig. 3-3: Optimization of the depth of field for the object

In autofocus mode and in combination with the OTS400 Omni Tracking System the CLV490 can also use the object height information from the OTS400 or any other CLV490 transmitted via the CAN bus.

3.2.2 Event-controlled dynamic focus control

As an alternative to the autofocus function, the CLV490 can switch its focus position in response to certain events and thus dynamically cover a large reading range. A maximum of eight reading ranges can be defined as distance configurations for this purpose and approached consecutively in reading mode (see Fig. 3-4).

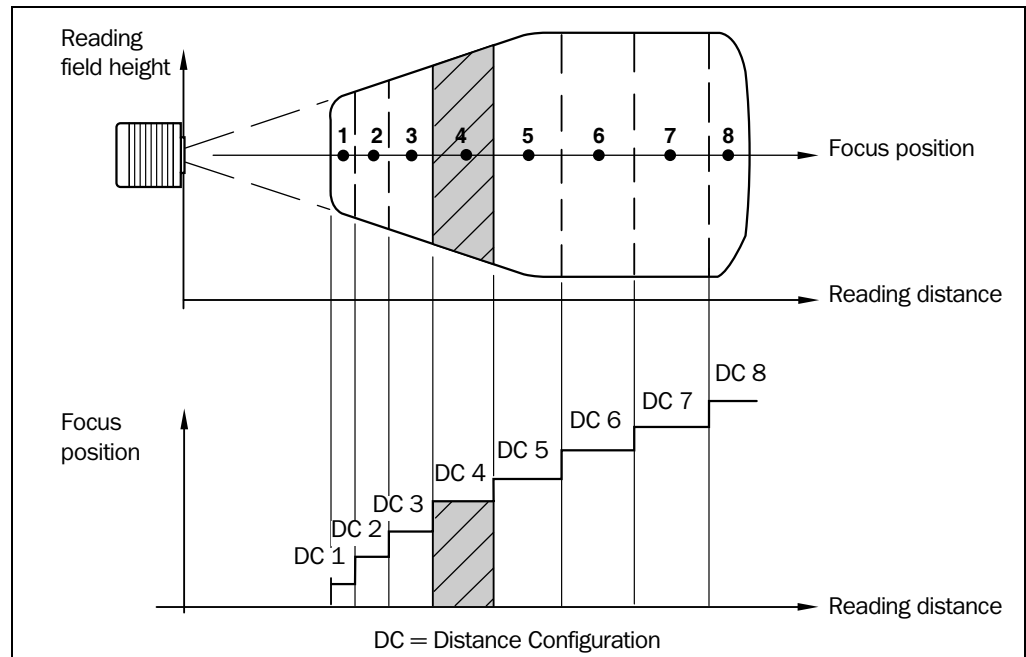

Fig. 3-4: Dynamic focus control: classification of the reading range in distance configurations

The switch over takes place in response to changes in the object distance (with reads from above: object height detection). The trigger source for the switchover can be:

- A signal combination at the "IN 0" to "IN 4" switching inputs, a command on the host interface/auxiliary interface or the integrated timer (e. g. for search mode). Additional in the case of the line scanner with oscillating mirror also the oscillating mirror reversal points. The distance configurations are assigned to the switchover sequence by means of a programmable assignment table.
- In combination with the OTS400 Omni Tracking System:
Alternatively the object height information from the OTS400 or any other CLV490 via the CAN bus.

The object distance measurement of the autofocus function can be additionally used to define the distance configurations.

3.2.3 Reading modes of the CLV490 in stand-alone configuration

Start/stop mode

During the reading process, only **one object** is located in the reading field in start/stop mode, i. e. all read bar codes can be clearly assigned to the object. As default, two reading pulse sensors at the beginning and at the end of the reading field control the starting and stopping of the reading process (Fig. 3-5). The size of the reading field is determined by the distance between the two sensors. Alternatively, the reading process can be controlled with

command strings via the data interface or can be left free running. The CLV490 either outputs the reading result at the end of the reading pulse (the back edge of the object has left the end of reading field) or already during the reading pulse as a result of predefined (parametrized) conditions. To separate bar codes of the same type with identical contents, an incremental encoder must be connected to the CLV490.

In object polling mode, the CLV490 automatically detects the beginning and the end of the object located in the reading field without any help of external sensors. The minimum temporal distance between two consecutive objects must not fall below 70 ms when the objects are moved on the conveyor belt.

Tracking mode

During the reading process, **max. 10 objects** can simultaneously be located in the reading field (following each other) (Fig. 3-5). As default, a reading pulse sensor at the beginning of the reading field controls the starting of the reading process. The end of the reading field is determined by the parametrized object release point in the CLV490. In this way, the size of the reading field is clearly determined.

In order to track the transport of the objects in the reading field, a regularly-timed pulse is required. This is generated by an external incremental encoder which regularly supplies a pulse at least every 10 mm (0.39 in) of movement in conveying direction. As a result, the the distance between the reading pulse sensor and the object release point is clearly time-mapped in the CLV490. Fluctuations when approaching the conveyor or decreases in speed due to heavy load with numerous conveyor objects are also recorded. An internal clock in the CLV490 also allows operation at a constant conveyor speed. A gap of at least 50 mm (1.97 in) is necessary for the clear separation of consecutive objects. The reading result for an object is output after the back edge of the object passes the object release point. Alternatively, the reading process can be started with a command strings via the data interface.

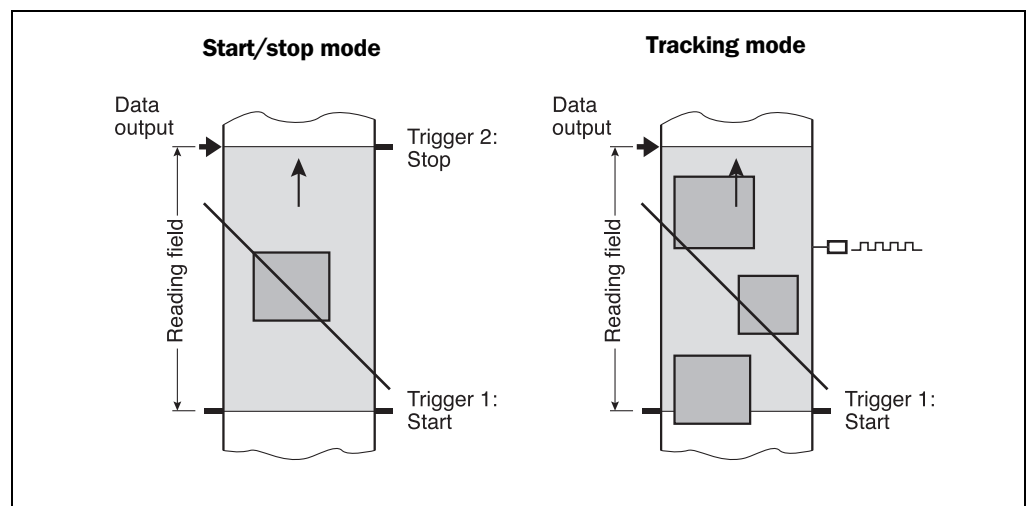

Fig. 3-5: Reading modes of the CLV490 in stand-alone configuration

3.2.4 Scan procedure variants

Line scanner (standard device)

Generates a scan line; due to the V-principle of the beam generation, the reading field height (the useful length of the scan line for evaluation purposes) is dependent on the reading distance.

Line scanner with oscillating mirror

The oscillating mirror also deflects the scan line perpendicularly to the scan direction at both sides around the neutral position with a low oscillating frequency. As a result, the CLV490 can also scan larger areas for bar codes. Due to the V-principle of beam generation, the reading field height is dependent on the reading distance.

In addition to parking (fixed position) and simple deflection with maximum amplitude, optimized oscillating mirror functions are also available:

- Oscillating with variable deflection amplitude per distance configuration
- One-Shot: one-off, defined deflection per reading pulse (forward and return phase)

3.2.5 Additional components

Heater

The CLV490 can be permanently equipped with a heater for applications involving temperatures up to max. -35 °C (-31 °F) (e. g. in a freezer).

The design, technical data, and power-up behavior of the CLV490 are described in [Chapter 10.4 Optional heating, Page 10-40](#).

External parameter memory in connector cover

The external parameter memory is located in a connector cover which, when mounted, covers the two electrical terminals on the CLV490 (IP 65). The parameter memory saves you time when a CLV490 is replaced locally by providing a copy of the current parameter set. In other words, you do not have to configure the new device.

For information on applications and operating procedures, see [Chapter 10.3 Installing and operating the external parameter memory \(connector cover\), Page 10-34](#).

3.3 Indicators and control elements

3.3.1 Control elements

The CLV490 is operated and configured via the auxiliary interface (auxiliary data interface) using the "CLV-Setup" program or using command strings sent via the host interface/auxiliary interface. A variety of parameter options allow you to adapt the device to a wide range of applications.

The following can be defined:

- The configuration of the code types
- The read, evaluation, and output properties
- The communication parameters of the host interface/CAN interface
- The structure of the data output string for "Good Read" and "No Read" on the host interface/CAN interface
- The function of the auxiliary interface

[Chapter 10.6 Installing and operating the "CLV-Setup" program, Page 10-43](#) describes the procedure for installing the "CLV-Setup" program and explains how to use it. The parameterization (configuration) procedure is explained in [Chapter 6.4 Configuring \(parameterization\) the CLV490, Page 6-5](#).

3.3.2 Function of the LEDs

Four LEDs indicate the operating status, activity of the laser diode, reading result status, and data transfer on the host interface. The LEDs are located on the rear of the device (Fig. 3-6). If the optional external parameter memory is connected, the LEDs also indicate whether the memory was successfully accessed.

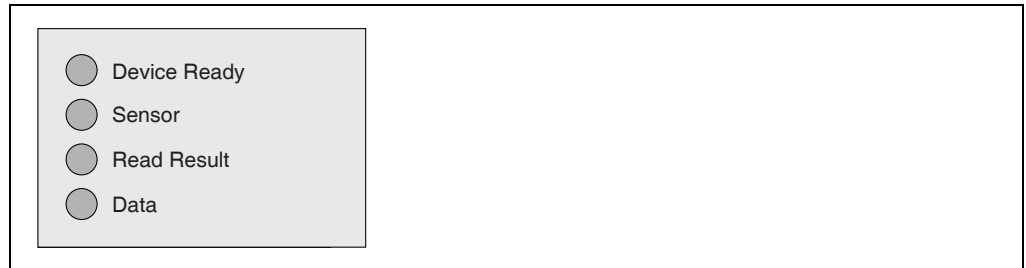

Fig. 3-6: LEDs

The meaning of the LEDs in the various operating modes/functions is shown in Table 3-2 and Table 3-3, Page 3-12.

CLV490 without external parameter memory:

Operating mode	LED	Display	Function
Start	Device Ready	Green	<ul style="list-style-type: none"> Lights up after power-up if the self-test was successful Subsequent behavior depends on selected start option: Start option: START WITH EXTERNAL PARAMETERS (default) <ul style="list-style-type: none"> Lights up constantly (CLV490 has loaded internal parameter set) Start option: START WITH INTERNAL PARAMETERS <ul style="list-style-type: none"> Lights up constantly (CLV490 has loaded internal parameter set) Start option: START WITH COPY INTERN -> EXTERN <ul style="list-style-type: none"> Blinks constantly together with the "Read Result" LED¹⁾ (CLV490 has loaded internal parameter set)
	Read Result	Green	Start option: START WITH COPY INTERN -> EXTERN <ul style="list-style-type: none"> Blinks constantly together with the "Device Ready" LED¹⁾
Reading mode	Device Ready	Green	<ul style="list-style-type: none"> Lights up constantly Extinguishes with new operating mode/function
	Sensor	Green	<ul style="list-style-type: none"> Lights up if reading diode is active (The laser diode is activated/deactivated by reading pulse) Lights up constantly in Free-running mode, since laser diode is always active
	Read Result	Green	LED is linked to the "Result 2" switching output and indicates the selected result status for the defined pulse duration of the output. <ul style="list-style-type: none"> Lights up after a successful read (default: Good Read) Lights up if the match code comparison is active, the bar code read matches the specified match code(s) and the corresponding result status output is selected for the "Result 2" output
	Data	Yellow	<ul style="list-style-type: none"> Flickers when the CLV490 transfers data to the host on the host interface

1) Set the start option to START WITH THE INTERNAL PARAMETERS on the DEVICE CONFIGURATION tab in the "CLV-Setup" program. Download to CLV490!

Table 3-2: Meaning of LEDs: CLV490 without external parameter memory

Operating mode	LED	Display	Function
Percentage evaluation	Sensor	Green	<ul style="list-style-type: none"> Lights up constantly, as Free-running mode is active Behavior depends on the reading quality: <ul style="list-style-type: none"> Extinguishes if reading rate < 30 % Blinks twice a second if reading rate 30 % to 70 % Blinks five times a second if reading rate 70 % to 90 % Lights up constantly if reading rate > 90 %
	Read Result	Green	
Adjusting mode	Sensor	Green	<ul style="list-style-type: none"> Lights up constantly, as Free-running mode is active
Show RA-limits	Sensor	Green	<ul style="list-style-type: none"> Blinks bright/dark alternately, in the frequency with which the scan line is (partially) masked out

1) Set the start option to START WITH THE INTERNAL PARAMETERS on the DEVICE CONFIGURATION tab in the "CLV-Setup" program. Download to CLV490!

Table 3-2: Meaning of LEDs: CLV490 without external parameter memory (contd.)

CLV490 with external parameter memory connected

a) External parameter memory in connector cover

Operating mode	LED	Display	Function
Start	Device Ready	Green	<ul style="list-style-type: none"> Lights up after power-up if the self-test was successful Subsequent behavior depends on selected start option: Start option: START WITH EXTERNAL PARAMETERS (default) <ul style="list-style-type: none"> Blinks for approx. 10 s before lighting up constantly (CLV490 has loaded the parameter set from the external parameter memory and starts reading mode straight away) Blinks for approx. 10 s together with the "Read Result" LED, then lights up constantly. (CLV490 has loaded the parameter set from the external parameter memory with tolerated errors¹⁾ and starts reading mode straight away) Lights up constantly (CLV490 could not find an external parameter memory and loads the internal parameter set instead) Blinks constantly together with the "Read Result" LED²⁾ (The external parameter memory contains the parameter set for a different CLV490 type or is corrupt. CLV490 has loaded the internal parameter set. It starts Reading mode but does not output data over the host interface.) Start option: START WITH INTERNAL PARAMETERS <ul style="list-style-type: none"> Lights up constantly (CLV490 has loaded internal parameter set) Start option: START WITH COPY INTERN -> EXTERN <ul style="list-style-type: none"> Blinks alternately with the "Read Result" LED for approx. 10 s before lighting up constantly (CLV490 has successfully copied the internal parameter set to the external memory and has reset the start option to START WITH EXTERNAL PARAMETERS). CLV490 has loaded the internal parameter set. Blinks constantly together with the "Read Result" LED²⁾ (The external parameter memory is either not connected or corrupt, or the parameter set is too large to be copied). CLV490 has loaded the internal parameter set.

1) We recommend that you check the parameter set manually, e. g. by printing out the entire configuration. For troubleshooting, see also [Chapter 8.3.2 LED error messages for the external parameter memory \(connector cover\), Page 8-3](#)

2) Stops blinking when you switch from Reading mode to Parameterization mode

Table 3-3: Meaning of LEDs: CLV490 with external parameter memory in the connector cover

Operating mode	LED	Display	Function
Start – continued –	Read Result – continued –	Green	<p>Start option: START WITH EXTERNAL PARAMETERS (default)</p> <ul style="list-style-type: none"> • Blinks for approx. 10 s together with "Device Ready" LED ¹⁾ (see above) or • Blinks constantly together with the "Device Ready" LED ²⁾ (see above) <p>Start option: START WITH COPY INTERN -> EXTERN</p> <ul style="list-style-type: none"> • Blinks alternately with "Device Ready" LED for approx. 10 s (see above) or • Blinks constantly together with the "Device Ready" LED ²⁾ (see above)
Reading mode	Device Ready	Green	<ul style="list-style-type: none"> • Lights up constantly • Extinguishes with new operating mode/function
	Sensor	Green	<ul style="list-style-type: none"> • Lights up if reading diode active (The laser diode is activated/deactivated by the reading pulse) • Lights up constantly in Free-running mode, since the laser diode is constantly active
	Read Result	Green	<p>LED is linked to the "Result 2" output and indicates the selected result status for the defined pulse duration of the output.</p> <ul style="list-style-type: none"> • Lights up after a successful read (Good Read) • Lights up if the match code comparison is active, the bar code read matches the specified match code(s) and the corresponding result output is selected for the "Result 2" output
	Data	Yellow	<ul style="list-style-type: none"> • Flickers when the CLV490 transmits data to the host over the host interface
Percentage evaluation	Sensor	Green	<ul style="list-style-type: none"> • Lights up constantly, since Free-running mode is active
	Read Result	Green	<p>Behavior dependent on the reading quality:</p> <ul style="list-style-type: none"> • Extinguishes if reading rate < 30 % • Blinks twice a second if reading rate 30 % to 70 % • Blinks five times a second if reading rate 70 % to 90 % • Lights up constantly if reading rate > 90 %
Adjusting mode	Sensor	Green	<ul style="list-style-type: none"> • Lights up constantly, since Free-running mode is active
Show RA-limits	Sensor	Green	<ul style="list-style-type: none"> • Blinks bright/dark alternately, in the frequency with which the scan line is (partially) masked out

1) We recommend that you check the parameter set manually, e. g. by printing out the entire configuration. For troubleshooting, see also [Chapter 8.3.2 LED error messages for the external parameter memory \(connector cover\), Page 8-3](#)

2) Stops blinking when you switch from Reading mode to Parameterization mode

Table 3-3: Meaning of LEDs: CLV490 with external parameter memory in the connector cover (contd.)

b) External parameter memory CMC400 in the CDB420/CDM490 Connection Module



The function of the "Device Ready" and "Read Result" LEDs on the CLV490 when using the CMC400 as well as the remedy for error messages are described in the *CMC400 Operating Instructions* (order no. 8010002, German/English).

See also [Chapter 10.3.1 Function of the external parameter memory, Page 10-35](#).

Notes:

4 Installation

4.1 Installation sequence

- Change the language version of the laser warning label (if necessary)
- Select the mounting location for the CLV490
- Mount the CLV490 and align the CLV490 with the bar code
- Mount the CDB420 or CDM490 Connection Module
- Connect the CLV490 to the CDB420 or CDM490 Connection Module
- Adjust the CLV490 so that it is in line with the bar code
- Mount the reading pulse sensor for external triggering the reading pulse
- Option with event-controlled dynamic focus control:
mount the sensors for detecting the object distance

Note Don't open the device. The warranty will be forfeited if the device is opened.

4.2 Preparations

4.2.1 Required components

- CLV490 Bar Code Scanner

4.2.2 Required accessories

- SICK mounting bracket for the CLV490: depending on the order, angle bracket no. 2013824, articulated bracket no. 2018435, angle bracket no. 2022996, or quick-clamping device no. 2016110 with securing material for the CLV490

– or –

Alternatively, if the bracket is supplied by the user

- Stable mounting device that allows the alignment of the CLV490 to be varied in the x and y axes. The weight of the CLV490 (line scanner) is 1.5 kg (3.3 lb) and 2.2 kg (4.84 lb) as a line scanner with oscillating mirror.
- 2 screws M6 for the CLV490. The screw length depends on the wall thickness of the bracket used. Depth of engagement in **CLV490 max. 7 mm (0.28 in)** from housing surface.
- CDB420 or CDM490 Connection Module (not included in the scope of supply of the CLV490)
- Reading pulse sensor for external reading pulse triggering, e. g. photoelectric reflex switch/ photoelectric proximity switch (not included in the scope of supply of the CLV490)
- Option with event-controlled dynamic focus control: sensors for detecting the object distance, e. g. photoelectric reflex switches/photoelectric proximity switches (not included in the scope of supply of the CLV490)
- Optionally for internal tracking: an incremental encoder (not included in the scope of supply of the CLV490)

4.2.3 Required auxiliary parts

- 2 screws M6 for securing the SICK mounting bracket to the base. The screw length depends on the wall thickness of the base.
- Set of laser warning labels (if necessary)
- Tool

- Measuring tape (up to 3 m (118.2 in))
- Protractor

4.2.4 Replacing the laser warning label

If necessary, replace the GB/US laser warning label with the required language (*Fig. 4-1*).

The device is delivered with a set of laser warnings in:

- German/US laser warning and
- French/US laser warning

See also *Chapter 2.3 General safety instructions and protection measures, Page 2-2*.

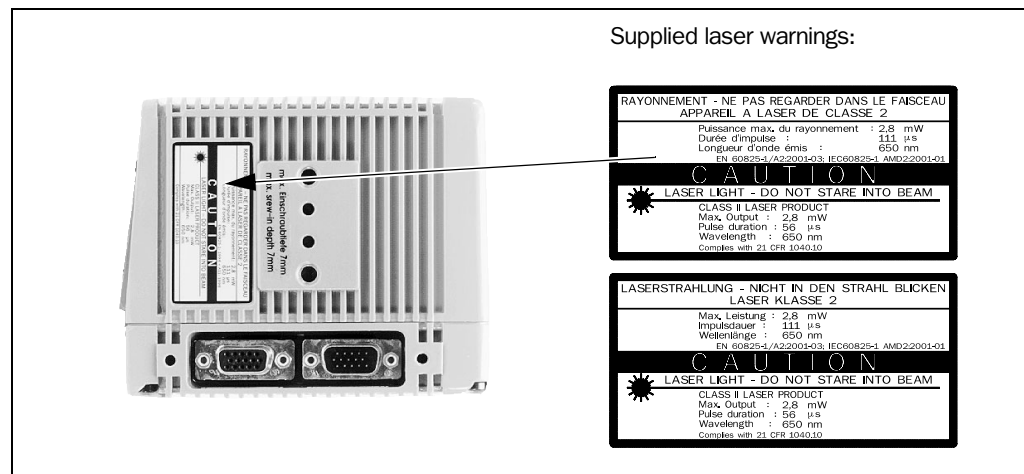

Fig. 4-1: Line scanner: replacing the laser warning labels

4.2.5 Selecting the mounting location

When you select the mounting location, the distance between the CLV490 and the host and between the CLV490 and the bar code are extremely important.

Distance between the CLV490 and the host

The CLV490 can be mounted at a maximum distance of 1,200 m (3, 937 ft) from the host without a connection to the SICK network or a bus. In practice, however, the distance depends on the physical configuration of the host interface and the data transfer rate (see *Table 5-19, Page 5-16*).

Distance between the CLV490 and the CDB420 or CDM490 Connection Module

The CDB420 or CDM490 Connection Module should not be located further than 10 m (32.8 ft) from the CLV490, since the "CLV-Setup" program on the PC accesses the auxiliary interface (RS 232) of the CLV490 via this module.

4.2.6 Mounting accessories

The CLV490 is secured in position using the two tapped blind holes (M6) above the electrical connections. *Fig. 4-2* shows the location of the threads near the line scanner.

The dimensions of the CLV490 housing are shown in *Fig. 9-1, Page 9-4* to *Fig. 9-2*.

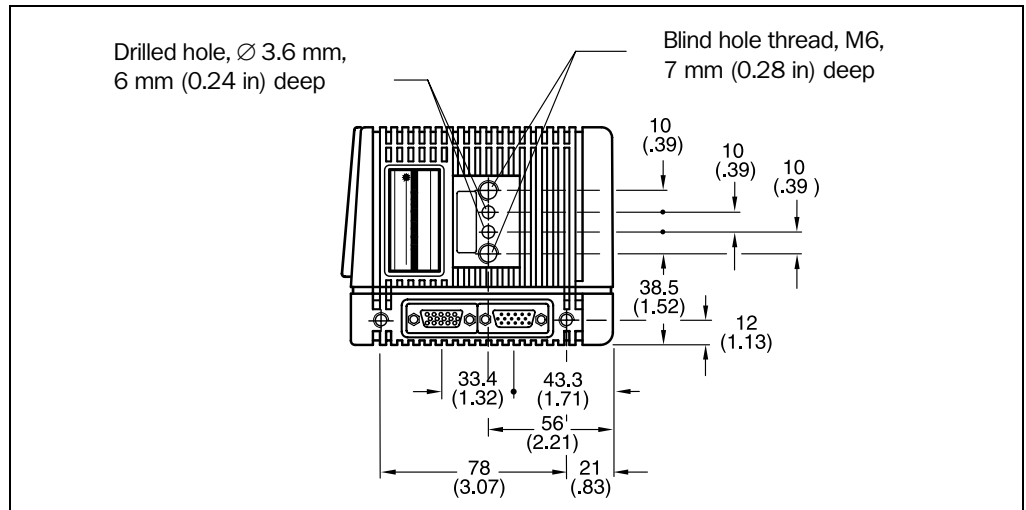

Fig. 4-2: Line scanner: position of the securing threads on the CLV490

The CLV490 can be mounted using the SICK bracket:

- Mounting bracket, single no. 2013824
- Articulated bracket (2 x mounting bracket, single) no. 2018435
- Quick-clamping device no. 2016110
- Mounting bracket no. 2022996

The brackets are designed to support a variety of mounting positions and alignments in two planes. Fig. 4-3 shows two mounting examples.

The elongated holes in the mounting bracket no. 2013824 and in the articulated bracket no. 2018435 allow the CLV490 to be adjusted with a freedom of rotation of $\pm 15^\circ$.

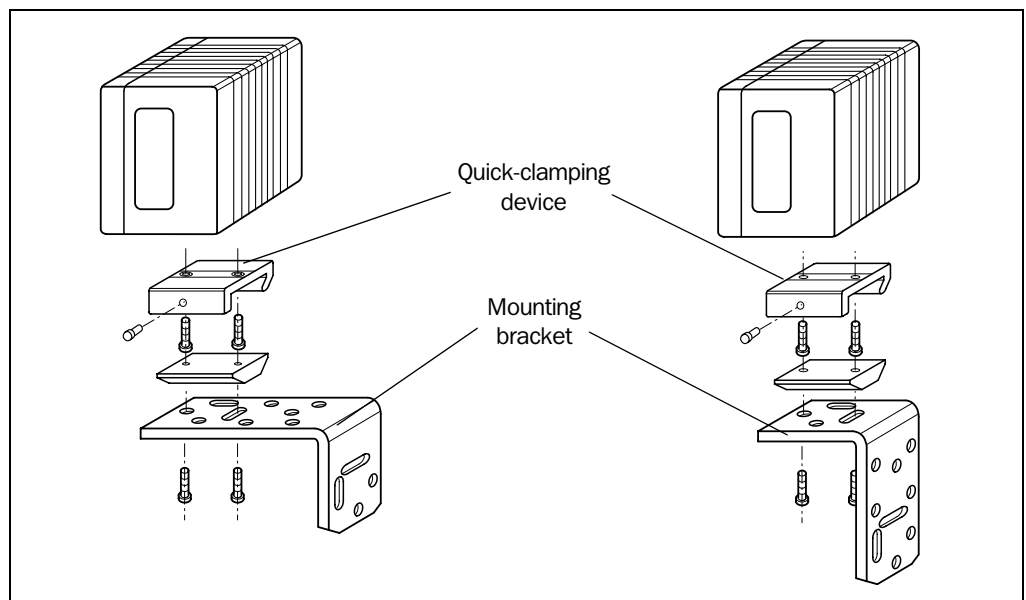

Fig. 4-3: Line scanner: Mounting possibilities of the CLV490

The dimensions of the mounting brackets are shown in [Chapter 10.14 Dimensioned drawings of the accessories, Page 10-83](#)

4.2.7 Distance between the CLV490 and the object

Basic alignment between the CLV490 and the bar code

Depending on the application, the line scanner or line scanner with oscillating mirror versions of the CLV490 is used. Fig. 4-4 shows how the device is aligned with the bar code on the object for each of the two scanning methods.

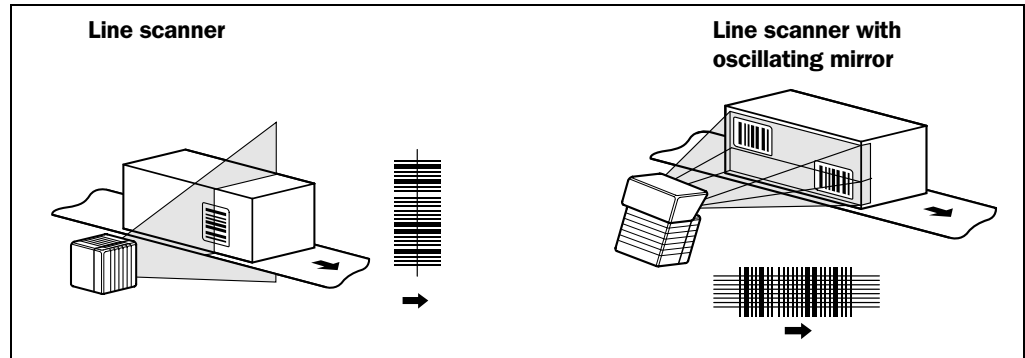

Fig. 4-4: Scanning methods: alignment with bar code and conveyor direction

Reading distance from the object and aperture angle α

The distance between the reading window of the CLV490 and the objects must not exceed the technical limits. The height of the reading field is shown as a function of the reading distance for various resolutions (module widths) depending on the CLV490 type in Chapter 10.2 Specification diagrams, Page 10-1.

Fig. 4-5 shows the definition of the reading distance "a" (radial measured) from the reading window and of the aperture angle α each of the two scanning methods.

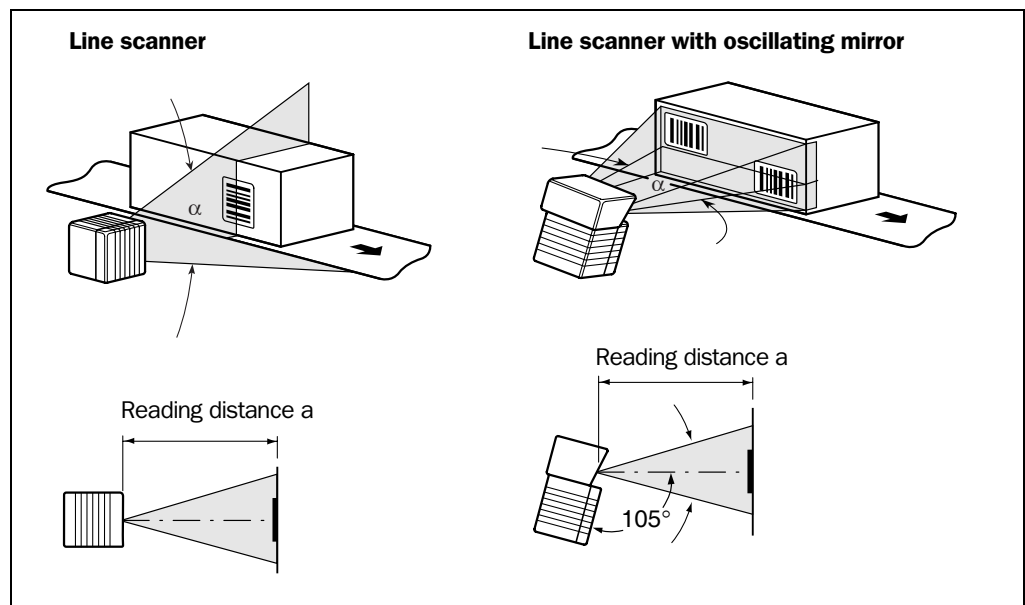

Fig. 4-5: Definition of the reading distance "a" and of the aperture angle α

The useful aperture angle is typically **56°** for the line scanner and max. **50°** for the line scanner with oscillating mirror. Due to the V-principle of beam deflection, the reading field height (for evaluating the useful length of the scan line) depends on the reading distance.

Angular alignment of the CLV490

The alignment of the CLV490 is optimum when the scan line travels over the bar code lines almost at a right angle (90°) (Fig. 4-4). All possible reading angles that can occur between the scan line and the bar code must be taken into consideration (Fig. 4-6 and Table 4-1).

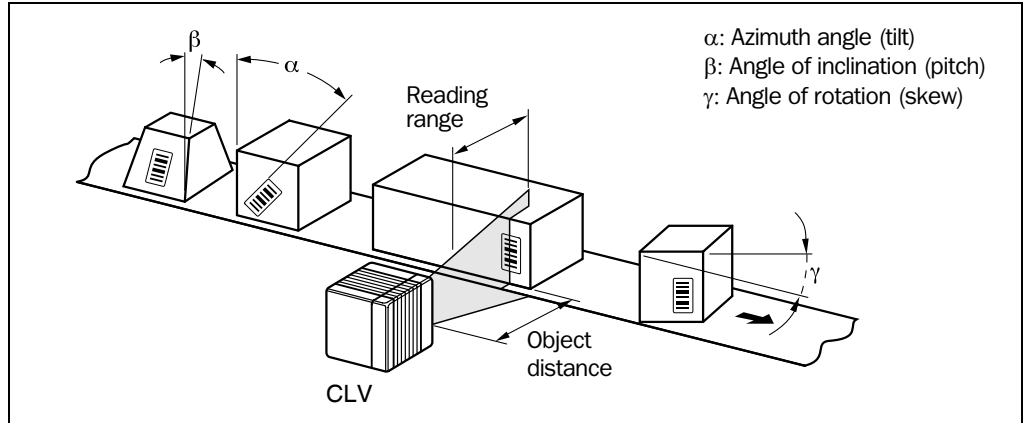

Fig. 4-6: Line scanner: Reading angle between the scan line and the bar code

Angle	Limit value
Tilt α (azimuth)	max. 45°
Pitch β	max. 45°
Skew γ	max. 45°

Table 4-1: Permissible reading angles between the scan line and bar code

Note If reading from the front, mount the CLV490 above the conveyor belt in such a way against the conveying direction that the scan line hits the object under a skew of approx. 10°.

Avoiding surface reflection

If the light from the scan line strikes the surface of the bar code vertically, interference may be caused by reflections when the returned light is received. To avoid surface reflection, the CLV490 must be mounted in such a way that the emitted light is tilted slightly with respect to the vertical axis (Fig. 4-7).

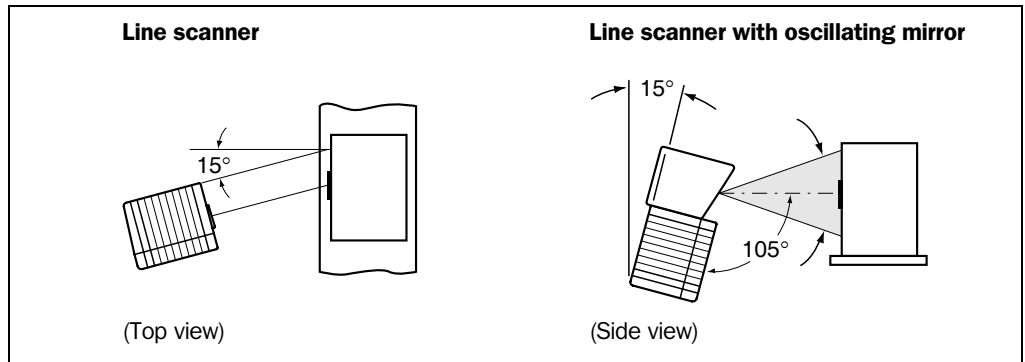

Fig. 4-7: Avoiding surface reflections: Angle between the emitted light and the bar code (tilted away from the vertical axis)

In the case of the line scanner with oscillating mirror, the laser beam is emitted at an angle of 105° with respect to the housing as it passes through the neutral position (CW = 50) while oscillating. The device can only be flush-mounted with the conveyor belt with limited deflection ranges. Otherwise, the device must also be mounted at an angle of 15° to ensure that the deflection ranges are symmetric.

Note In oscillating mode with variable amplitude, the scan line must always sweep the neutral position (CW = 50). This means that oscillation is not possible in the range 60 CW to 80 CW, for example, but is possible in the range 40 CW to 80 CW.

4.2.8 Count direction of the reading angle RA and code angle CW

Explanation The CLV490 can scan and decode several bar codes with each read. In doing so, it determines the specific local reading diagnosis data for each bar code:

- The reading angle (RA value) of the center of the bar code within the scan line
- (Scanning method using the oscillating mirror) also the angle of deflection of the scan line (CW value) at which the center of the bar code is recorded

Fig. 4-8 shows the count direction of the reading angle and code angle. In the case of the line scanner, the count direction of the reading angle is marked by a small triangle above the reading window.

By determining this data, the device can separate identical bar codes.

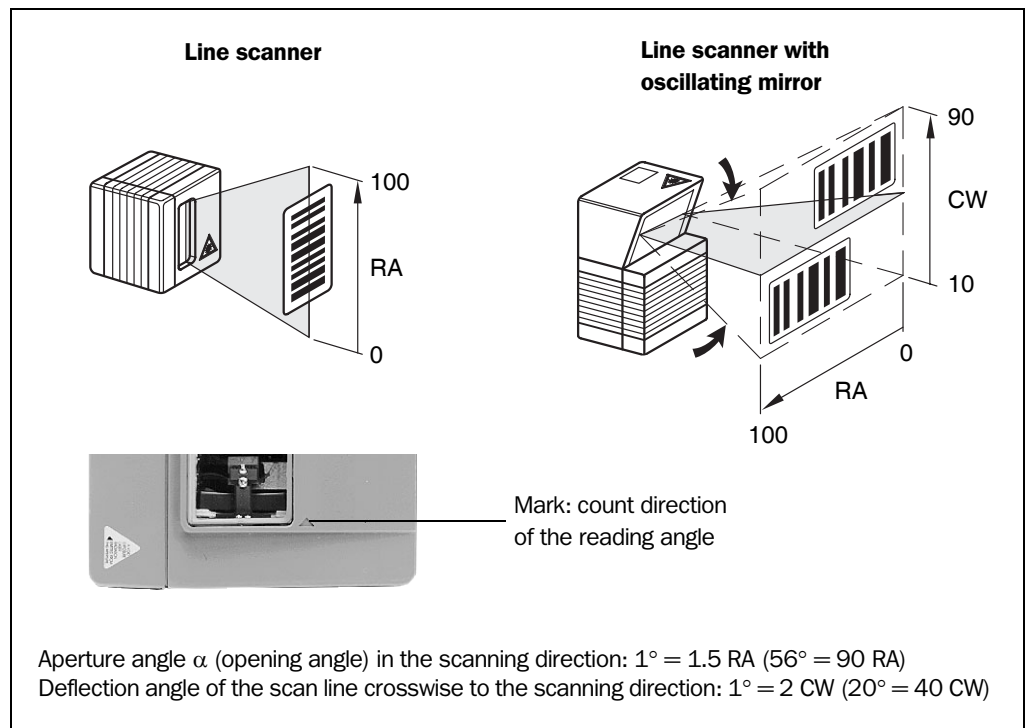



Fig. 4-8: Count direction of the reading angle RA in the scan line and of the code angle CW for the oscillating mirror



Tip In the default setting, the CLV490 does not output the "RA" and "CW" values (line scanner with oscillating mirror only) in the reading result on the host interface. If this is required to evaluate the result in the host, the values can be included in the "Code-Info/Separator" block of the output string using the "CLV-Setup" program.

Configuring the Code-Info/Separator:

1. Choose the DATA STRINGS tab.
2. Click the CODE-INFO/SEPARATOR field.
The EDIT PARAMETER TFS dialog box is displayed.
3. In the list field, click the RA and/or CW parameters.
RA and/or CW then appears in the top line.
4. Confirm your selections with OK.
5. Download the data to the CLV490 by clicking  in the toolbar.
The DOWNLOAD PARAMETERS dialog box is then displayed.
6. Confirm the dialog box by choosing PERMANENT.
The CLV490 outputs the RA value and the CW value on the host interface for each bar code in the reading result. The values are displayed as a 3-digit number in the associated "Code-Info/Separator" block.

4.3 Mounting and adjusting the device**4.3.1 Mounting the CLV490**

1. Prepare the base for mounting the bracket as described in [Chapter 4.2.2 Required accessories, Page 4-1](#).
2. Place the object containing the bar code within the reading field of the CLV490 (in the position at which it is to be read) with the conveyor belt switched off.
3. Align the CLV490 with the bar code (in accordance with the scanning method) in such a way that
 - with the line scanner the back of the device with the LEDs is almost parallel with the bar code surface,
 - with the line scanner with oscillating mirror, the broad side wall (back of the oscillating mirror) is almost parallel with the bar code surface
 All of the possible reading angles must be taken into consideration (see [Fig. 4-6, Page 4-5](#)).
4. If it is relevant for the evaluation, note the count direction of the reading angle and code angle (see [Fig. 4-8, Page 4-6](#)).
5. Mount the CLV490 bracket on the base.

**Risk of damage to the device**

The maximum depth of engagement of the two blind hole threads M6 is 7 mm (0.28 in). Longer screws will damage the device.

- Use screws with the correct length.

6. Screw the screws M6 through the bracket into the blind hole threads of the CLV490.
7. Tighten the screws slightly.
8. Adjust the CLV490 as described below.

4.3.2 Adjusting the CLV490



The CLV490 can be adjusted in Percentage Evaluation mode. In this mode, the CLV490 displays the quality of the bar code reads that enter the CLV490 reading field statically (the object is not moved on the conveyor belt). The CLV490 performs 100 scans and evaluates the reading quality statistically. It then outputs the reading results every 2 s on the auxiliary interface.

Note In default setting, the CLV490 operates in the autofocus mode "Minimum distance". As a result, the CLV490 focuses on the object that is nearest in Percentage Evaluation mode. The view on the object with the scan line must be unobstructed, i. e. any other objects must not protrude into the autofocus space. If they do so, the autofocus mode "Differential background" must be selected. Alternatively a fixed focus position can be set. See [Chapter c\) Parameterizing focus control, Page 6-12](#).

The behavior of the "Read Result" LED also indicates the reading quality:

- The LED is extinguished if reading quality is < 30 %
- The LED flashes twice per second if the reading quality is 30 % to 70 %
- The LED flashes five times per second if the reading quality is 70 % to 90 %
- The LED is lit continuously if the reading quality is > 90 %

The scanning frequency in the default setting is 800 Hz.

1. Connect the CLV490 to the CDB420 or CDM490 Connection Module and switch on the power supply (see [Chapter 5.5.3 Connecting the supply voltage, Page 5-18](#)). After it has started, the CLV490 confirms that the self-test was successfully and switches to reading mode ("Device Ready" LED lights up).
2. Connect the PC to the auxiliary interface of CLV490. To do so, connect a 3-core RS 232 data cable (null modem cable) to the internal 9-pin "Aux" plug of the CDB420 or CDM490 (see [Chapter 5.5.6 Connecting the PC, Page 5-21](#)).
3. Start Windows and the "CLV-Setup" program (see [Chapter 10.6.3 Starting CLV-Setup, Page 10-46](#)).

Choosing the standard decoder:



4. Choose the CODE CONFIGURATION tab.
5. Click the STANDARD option in the DECODER section.
6. Download the settings to the CLV490.
To do so, click the STANDARD option again with the right mouse button and choose DOWNLOAD PARAMETER in the context menu.
CLV-Setup copies the parameter to the CLV490 temporarily.
The CLV490 then operates with the standard decoder (until the CLV490 is switched off).

Activating Percentage Evaluation mode:

7. From the VIEW menu, choose PERCENTAGE EVALUATION.
The dialog box for entering the distance configuration appears.
8. Click the relevant distance configuration for the reading distance:
 - with autofocus mode the distance configuration no. 1
 - with event-controlled dynamic focus control the distance configuration that matches the reading distance of the object (default: no. 1, focus position $F = 1,200$ mm (47.3 in)).
9. Confirm the dialog box with OK.

The Terminal Emulator is launched and displays the reading result continuously (see [Chapter 6.5.2 Percentage evaluation, Page 6-41](#)).

Monitor the **reading quality (%)** during each of the subsequent steps!

Line scanner with oscillating mirror:

In the "Percent Evaluation" mode, the CLV490 behaves in the following manner:

- in "Oscillating" mode (default setting: oscillating with a fixed amplitude), the CLV490 shuts off oscillation and positions the scan line under the angle $CW = 50$ (corresponds to an angle of deflection of 105°). This position cannot be altered.
- in "One-Shot" mode, the CLV490 also positions the scan line under the angle $CW = 50$
- in "Set Position" mode, the scan line's selected position remains unchanged.

Performing fine adjustment:

10. Align the CLV490 in such a way that the angle between the scan line and the bars on the bar code CLV490 is almost 90° . The oscillating mirror must be aligned in such a way that the scan line is located at the center of the bar code, perpendicular to the bar code lines, when it is in the neutral position ($CW = 50$).
11. To avoid interfering reflections, tilt the line scanner away from the vertical axis so that the light strikes the bar code at an angle of approx. 105° (see [Fig. 4-7, Page 4-5](#)).
12. If necessary, position the scan line exactly at the direct center of the bar code. See [Chapter 4.3.3 Adjusting mode](#) below.
13. Move objects carrying bar codes into the CLV490 reading field manually under realistic conditions and check the reading result. If the objects are aligned randomly, or if the bar code is located at different positions (angles), ensure that the limit values of the permissible reading angles are not exceeded.
14. Adjust the CLV490 in such a way that the good read rate is between **70 ... 100 %**. With event-controlled dynamic focus control, for each defined reading range (distance configuration), check the selected focus position and correct the parameter settings if necessary (see [Chapter 6.4.4 Guide to parameterization menu, Page 6-9](#)).
15. Tighten the screws on the CLV490.

The CLV490 is aligned with the bar code.

4.3.3 Adjusting mode

The "Adjusting mode" helps you to position the **center** of the scan line on the object. To do so, the CLV490 masks out one half of the scan line from the center (reading angle RA = 50 to RA = 100). This is irrespective of whether the CLV490 is operated in Autofocus mode or with distance configurations for event-driven dynamic focus control. [Fig. 4-9, Page 4-10](#) shows the resulting position of the scan line (line scanner).

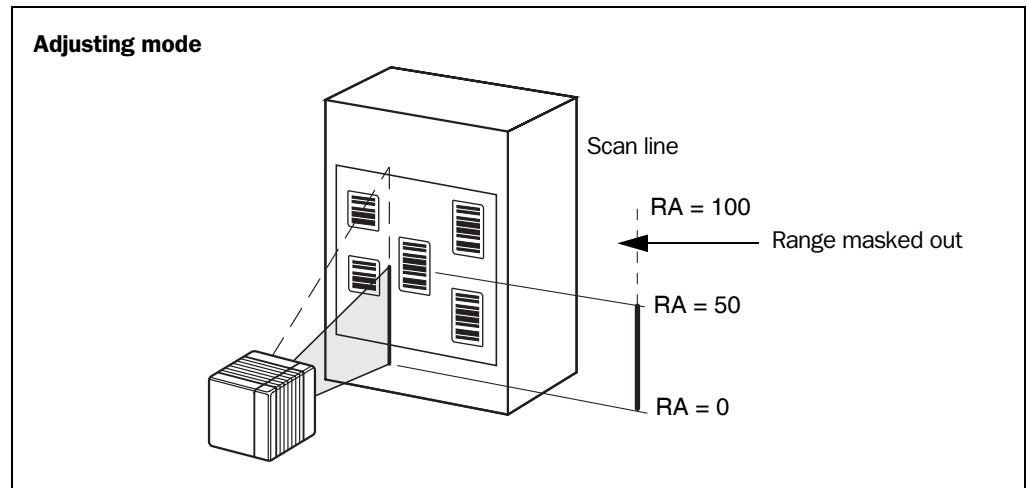

Fig. 4-9: Line scanner: scan line in Adjusting mode

Line scanner with oscillating mirror:

In "Adjusting" mode, the oscillating mirror behaves in the same manner as within the "Percent Evaluation" mode (see [Page 4-8, "Activating Percentage Evaluation mode:"](#)).

1. Activate the operating mode as described in [Chapter 6.5.3 Adjusting mode, Page 6-43](#).
2. Position the CLV490 in such a way that the center of the scan line, indicated by the end of the scan line (reading angle RA = 50), is located at the center of the bar code, or at the center of the field for all codes if several bar codes are used.

Show RA-limits

The "Show RA-limits" operating mode allows you to test whether the desired effect was produced by narrowing the scan line's active evaluation range. The CLV490 alternatively hides certain parts of the scan line in accordance with the selected min. and max. values of the reading angle.

For activation of this operating mode and for checking, See [Chapter 6.5.5 Show RA-limits, Page 6-46](#).

4.4 Mounting the external components

4.4.1 Mounting the CDB420 or CDM490 Connection Module

1. Mount the CDB420 or CDM490 Connection Module near the CLV490.
The distance between the connection module and CLV490 should not exceed max. 10 m (32.8 ft).
2. Mount the CDB420 or CDM490 in such a way that accessed to the open device is always possible. The auxiliary interface of the CLV490 is accessed via the 9-pin, internal "Aux" plug.



Detailed information on the mounting and electrical installation procedures is provided in the "CDB420 Connection Module" Operating Instructions (order no. 8010001, German/English) respectively in the "CDM490 Connection Module" Operating Instructions (order no. 8010005, German/English).

4.4.2 Mounting the external reading pulse sensor

If the CLV490 is triggered by an external reading pulse sensor, the sensor must be mounted in the vicinity of the CLV490. The "Sensor" switching input is selected as the default trigger source for this trigger type. The default debounce time of the input is 30 ms.

[Fig. 4-10](#) shows two examples of where a photoelectric reflex switch can be mounted. This depends on the distance a from the bar code to the front of the object. Depending on the application, you may need to mount the sensor in such a way that bar codes on objects of different sizes can be read completely during the reading interval ("internal reading gate").

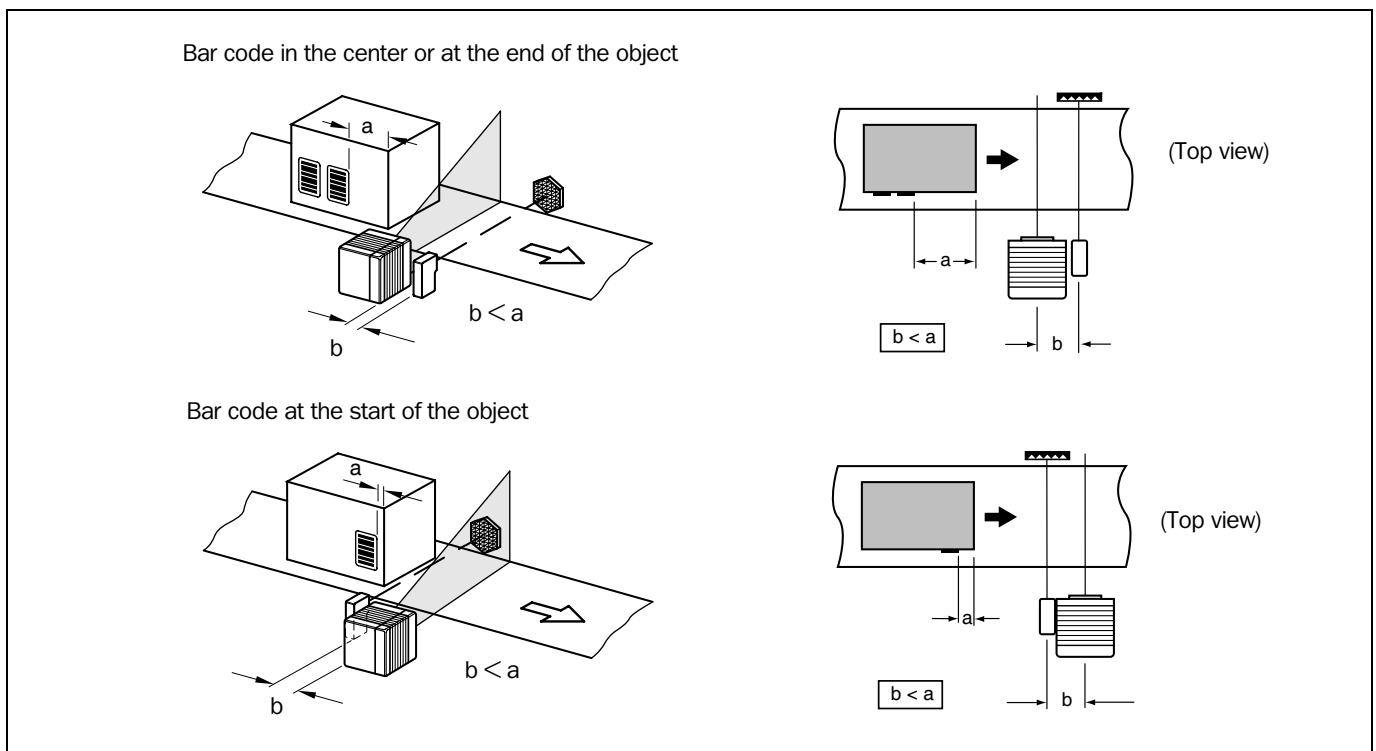

Fig. 4-10: Line scanner: mounting example for the external reading pulse sensor

Note In default setting, the CLV490 operates in the autofocus mode "Minimum distance". As a result, the CLV490 focuses on the object that is nearest in Percentage Evaluation mode. The view on the object with the scan line must be unobstructed, i. e. any other objects must not protrude into the autofocus space. If they do so, the autofocus mode "Differential back-

ground“ must be selected. Alternatively a fixed focus position can be set. See [Chapter c\) Parameterizing focus control, Page 6-12](#).

Installing the reading pulse sensor for start/stop mode:

1. Mount the reading pulse sensor.
2. Connect the reading pulse sensor to the "Sensor (1)" switching input of the CLV490 via the CDB420 or CDM490 Connection Module (see [Chapter 5.5.7 Connecting the "Sensor" switching input, Page 5-22](#)).
3. Connect the CLV490 to the CDB420 or CDM490 Connection Module and switch on the power supply to the module (see [Chapter 5.5.3 Connecting the supply voltage, Page 5-18](#)).

After it has started, the CLV490 confirms that the self-test was successful and switches to Reading mode ("Device Ready" LED lights up).

4. Connect the PC to the auxiliary interface of CLV490. To do so, connect a 3-core RS 232 data cable (null modem cable) to the internal 9-pin "Aux" plug of the CDB420 or CDM490 (see [Chapter 5.5.5 Connecting the CAN interface, Page 5-21](#)).
5. Start Windows and the "CLV-Setup" program (see [Chapter 10.6.3 Starting CLV-Setup, Page 10-46](#)).



6. From the VIEW menu, choose READING MODE.
The Terminal Emulator is launched. The CLV490 is in Reading mode (default: SMART decoder).

Monitor the reading result during each of the subsequent steps!

Line scanner with oscillating mirror:

In default setting, the CLV490 deflects the scan line (default setting) about the fixed position $CW = 50$ with a frequency of 1 Hz at a max. angle of $\pm 20^\circ$ (± 40 CW).
50 CW corresponds to an angle of emergence of 105° .

7. Move objects with bar codes into the CLV490 reading field manually under realistic conditions and check whether the reading result and trigger pulse are correct.
8. Repeat the procedure with the conveyor switched on. Check whether the reading procedure is synchronized with the objects.

Parameterizing an external sensor as a trigger source:

These settings are not required if the CLV490 is operated with the default configuration.



1. Choose the DEVICE CONFIGURATION tab.
2. In the READING TRIGGER SOURCE section click the option SENSOR INPUT (ACTIVE HIGH).
3. Download the settings to the CLV490 by clicking  in the toolbar.
The DOWNLOAD PARAMETERS dialog box is then displayed.
4. Confirm the dialog box by choosing PERMANENT.
The CLV490 operates with the "Sensor" switching input as an external trigger source.
The reading pulse starts when the input is energized (high).

4.4.3 Installing incremental encoder

In the reading mode "Tracking", an incremental encoder is required for determining which bar codes belong to which objects. The encoder is also required to separate bar codes of the same symbology with identical content.

1. Install the incremental encoder (e. g. no. 2022714) near the CLV490 but in front of it, preferably against the direction of the conveyor belt. The increment pulses must originate from the area of the conveyor belt which the CLV490 is reading.

2. Ensure that the incremental encoder is contacting the conveyor and that the friction wheel turns without slipping.
3. Connect incremental encoder to the "IN4" switching input of the CLV490 (not available via the terminals of the CDB420 Connection Module). See [Chapter 5.5.8 Connecting the "IN 0" to "IN 4" switching inputs, Page 5-23](#).

4.4.4 Mounting the sensors for detecting the object distance

If the dynamic focus control function of the CLV490 is triggered by external sensors, suitable sensors must be mounted in the vicinity of the CLV490. [Fig. 4-11](#) shows an example of a read operation from above. The sensors must be arranged in such a way that all of the potential object heights are classified uniquely and overlapping reading ranges occur that can be formed with the depths of field of the CLV490. A maximum of five switching inputs are available for this purpose. A max. of 32 switching states for 8 distance configurations (reading ranges) can be implemented using the internal assignment table (combinations). Photoelectric reflex switches, for example, can be used to detect the object distance. In the default setting, all five "IN 0" ... "IN 4" switching inputs are selected for dynamic focus control.

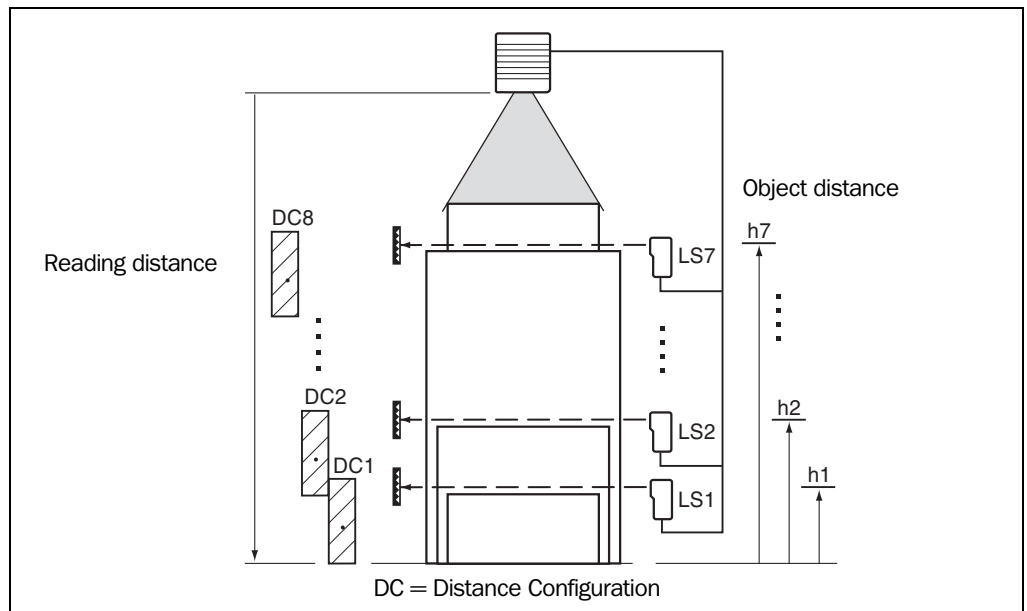

Fig. 4-11: Mounting example for object distance detection

1. The depths of field of the CLV490 for the bar code resolution in question is shown in the graphs in [Chapter 10.2 Specification diagrams, Page 10-1](#) onwards. Find and note suitable focus positions for overlapping reading ranges.
2. Mount distance sensors (e. g. photoelectric reflex switches) one above the other in a row at the mounting location to measure the object distance (see also assignment [Table 5-26, Page 5-24](#)). It is advisable to mount these distance sensors opposite the direction of motion of the conveyor belt at approx. 100 mm (3.94 in) in front of the reading pulse sensor.
3. Connect the distance sensors to the "IN 0" ... "IN 4" switching inputs on the CLV490 via the CDB420 or CDM490 Connection Module (see [Chapter 5.5.7 Connecting the "Sensor" switching input, Page 5-22](#)). Via the terminals of the CDB420 Connection Module only the IN 0 input can be connected.



4. Set the focus positions for the required reading ranges on the READING CONFIGURATION tab in the "CLV-Setup" program. To do so, choose the INPUTS/SERIAL option in the drop down list of the FOCUS CONTROL section.
5. Click the DISTANCE CONFIGURATION button and edit the required entries in the dialog box that is then displayed (default: Focus position F 1 up to F 8 = 1,200 mm (47.3 in)).
6. As described in [Chapter 4.3.2 Adjusting the CLV490, Page 4-8](#), choose the standard decoder.
7. Perform a temporarily download to the CLV490.
8. Start Percentage Evaluation mode.
9. Check the reading quality in all distance configurations while the conveyor belt stationary.
10. Then check the distance detection function in Reading mode under realistic conditions. To do so, monitor the reading result in the Terminal Emulator as described in [Chapter 4.4.2 Mounting the external reading pulse sensor, Page 4-11](#).
11. If the distance detection function operates correctly, reset the decoder to the SMART/STANDARD option and perform a permanently download to the CLV490.

Note The CLV490 can switch between a maximum of 8 distance ranges for slow search runs using the integrated timer or the oscillating mirror reversal points. The CLV490 can be switched between a maximum of 8 distance ranges synchronously to the reading process using command strings.

4.5 Dismantling the device

1. Switch off the power supply to the CDB420 or CDM490 Connection Module.
2. Undo the screws for the cable connections on the CLV490 and disconnect the cables.
With mounted external parameter memory (optional):
Undo both screws and remove the cover.
3. Unscrew the CLV490 from the mounting device.

When removing the device from service for the last time, please dispose of it in an environmentally-friendly manner, as described in [Chapter 7.4 Disposal, Page 7-3](#).

5 Electrical installation

5.1 Installation sequence

- Connect the CLV490 to a CDB420 or CDM490 Connection Module, or using a custom-specific wiring configuration
- Connect the data and function interfaces of the CLV490 in the module
- Connect the PC to the Connection Module (at the auxiliary interface on the CLV490)
- Connect the power supply to the Connection Module

5.1.1 SICK Connection Modules (overview)

CLV490 Type	Temperature range	Connection module	Purpose	see chapter
CLV490 without heater	0 to +40 °C (+32 to +104 °F)	CDB420-001 CDB420-101	<ul style="list-style-type: none"> – Connecting one CLV490 – 1 x 15-pin D Sub HD socket, 4 x cable gland (CDB420-101: 2 x cable gland, 2 x M12 plug connection (1 x plug, 1 x socket)) – Operating voltage 18 to 30 V DC – Enclosure rating max. IP 65 	5.2.3
		CDM490-0001	<ul style="list-style-type: none"> – Connecting one CLV490 – 1 x 15-pin D Sub HD plug, 1 x socket, 6 x cable gland – Operating voltage 18 to 30 V DC – Enclosure rating max. IP 65 	5.2.4
CLV490 with heater	–35 to +35 °C (–31 to +95 °F)	CDM490-0001	<ul style="list-style-type: none"> – Connecting one CLV490 – 1 x 15-pin D Sub HD plug, 1 x socket, 6 x cable gland – Operating voltage 24 V DC +20 %/–10 % – Enclosure rating max. IP 65 (with connector cover) 	5.2.4

Table 5-1: Connection Modules for the CLV490

For technical data on the modules see [Chapter 10.13.3 Accessories: Hoods, Page 10-75](#).

5.2 Electrical connections and cables

The electrical connections on the CLV490 consist of two 15-pin D Sub HD connections on the housing, one plug, and one socket.

These connections are used to route the following interfaces:

- Three data serial interfaces (host interface, CAN interface 1 and 2, auxiliary interface)
- Six switching inputs (external reading pulse and multifunctional inputs)
- Four switching outputs (for result status function, for connecting to a PLC for example)
- Power supply

5.2.1 Wire cross-sections

CLV490 without heater:

- All connections must be wired with copper cables with a minimum wire diameter of 0.15 mm² (approx. 26 AWG)!

CLV490 with heater:

- Connect the power supply terminals (Pin 1/Pin 5) using copper wires with a minimum cross-section of 0.75 mm² (approx. 20 AWG) at a maximum length of 10 m (32.8 ft)!

5.2.2 Prefabricated cables (overview)

CLV490 Type	Temperature range	Connection module	Optional cables	Length	Type
CLV490 without heater	0 to +40 °C (+32 to +104 °F)	CDB420	1 x no. 2027046 or	3 m (3.84 ft)	Connector cover (IP 65) to 15-pin plug
			1 x no. 2030023	3 m (3.84 ft)	Connector cover (IP 65) with parameter memory to 15-pin plug
		CDM490	2 x no. 2020302 or	3 m (3.84 ft)	Connection cable (15-pin plug/socket)
			2 x no. 2021815 or	10 m (32.8 ft)	Connection cable (15-pin plug/socket)
			1 x no. 2020307	3 m (3.84 ft)	Connector cover (IP 65) with parameter memory to 15-pin plug and 15-pin socket
		Non-Sick Power pack	1 x no. 2020303 +	3 m (3.84 ft)	Connection cable with 15-pin socket/open end
			1 x no. 2020264 or	3 m (3.84 ft)	Connection cable with 15-pin plug/open end
			1 x no. 2020981 or	3 m (3.84 ft)	Connector cover (IP 65) with parameter memory to two cables with open ends
			1 x no. 2021267	3 m (3.84 ft)	Connector cover (IP 65) to two cables with open ends
		CLV490 with heater	-35 to +35 °C (-31 to +95 °F)	CDB420	1 x no. 2033126 or
1 x no. 2033127	15 m (49.2 ft)				Connector cover (IP 65) with parameter memory to 15-pin plug and cable with open end (power supply), suitable for track chain use
CDM490	1 x no. 2030065 or			3 m (3.84 ft)	Connector cover (IP 65) with parameter memory to 15-pin plug and 15-pin socket as well as cable with open end (power supply), suitable for track chain use
	1 x no. 2031034 or			10 m (32.8 ft)	Connector cover (IP 65) with parameter memory to 15-pin plug and 15-pin socket as well as cable with open end (power supply), suitable for track chain use
Non-Sick Power pack	1 x no. 2021267			3 m (3.84 ft)	Connector cover (IP 65) to two cables with open ends

Table 5-2: Cables for connecting the CLV490

For technical data on the cables, see [Chapter 10.13.6 Accessories: Cables, external parameter memories in connector cover, connector covers, Page 10-79](#).

For function of the external parameter memory in the connector cover see [Chapter 10.3 Installing and operating the external parameter memory \(connector cover\), Page 10-34](#).

5.2.3 Connections/cables for the CDB420 Connection Modules



The CDB420 Connection Module is suitable for connecting **one CLV490 without/with heater** to peripherals (distribution function) and the power supply. The module can be used to establish a connection to the host (point-to-point) or to integrate the device in a SICK CAN Scanner Network. The module is available in two variants and can be operated without optional modules (see below) with an operating temperature to $-35\text{ }^{\circ}\text{C}$ ($-31\text{ }^{\circ}\text{F}$). For technical data see [Chapter 10.13.3 Accessories: Hoods, Page 10-75](#).

Optional modules for building-in into the CDB420:

- CMC400 Connection Module Cloning for saving the parameters of the CLV490 externally

Because only one 15-pin D Sub HD socket respectively screw terminal strips for the power supply via cable glands are available for connecting the CLV490 to the CDB420, the number of signals which can be connected using the terminal strips in the CDB420 are limited.

[Fig. 5-1](#) shows the connection principle of the CDB420.

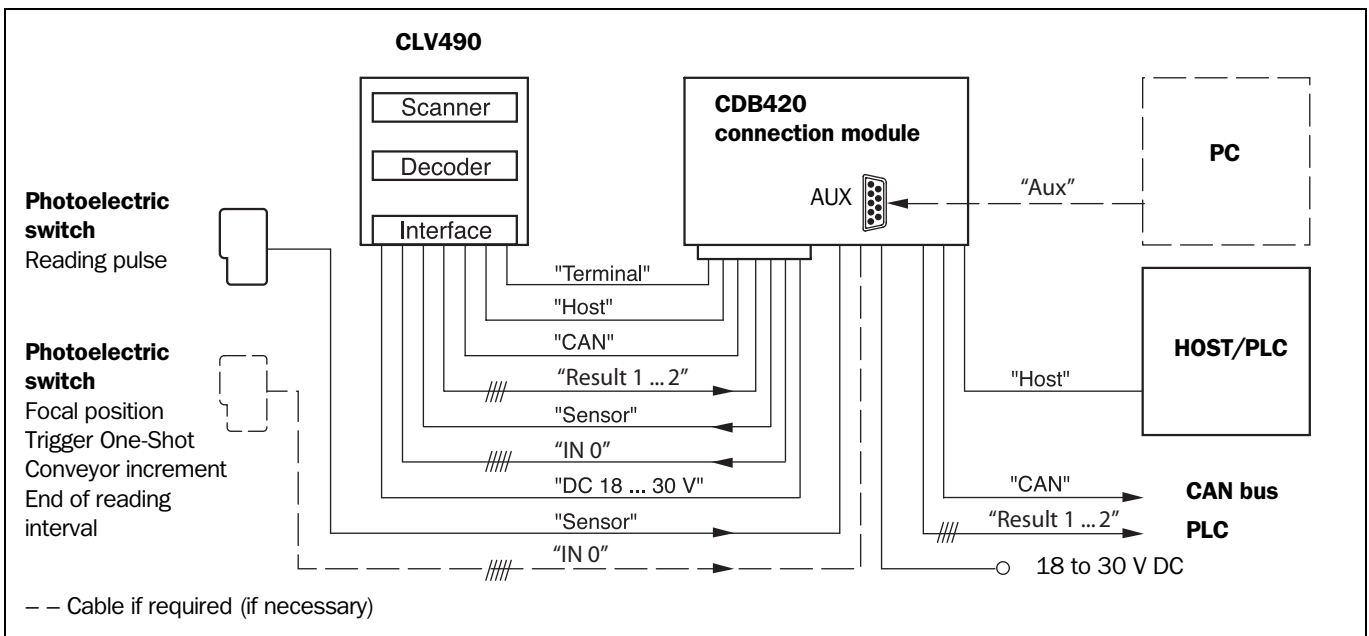

Fig. 5-1: Block diagram: Connection of the CLV490 to the CDB420 connection module



The procedures for connecting and configuring the connection module are described in the "CDB420 Connection Module" *Operating Instructions* (order no. 8010001, German/English).

Note Diagrams showing you how to connect the CDB420 Connection Module are also available in the "CLV Connect" PC program. This software is available on the "Manuals & Software" CD-ROM, which is included in the scope of delivery of the CLV490. The software can also be downloaded from the SICK home page (www.sick.com) at "Service&Support/Download-pool". It can be called up using a standard HTML browser (e. g. Internet Explorer™).

Connecting the CLV490 to the CDB420

a) CLV490 without heater

The following connection cables **with** connector cover for the CLV490 can be used:

No. 2027046 (3 m (3.84 ft)) or no. 2030023 (3 m (3.84 ft)).

The cables can be extended to 10 m (32.8 ft) (auxiliary interface: RS 232!).

b) CLV490 with heater:

The following connection cables **with** connector cover for the CLV490 can be used:

No. 2033126 (10 m (32.8 ft)) or no. 2033127 (15 m (49.2 ft), however not when the RS 232 host interface is used)).

The cables must **not** be extended! If longer cables are required, the entire power supply system (Pin 1/Pin 5) must be connected with a wire cross-section of at least 0.75 mm² (approx. 20 AWG) with a maximum length of 10 m (32.8 ft).

Note To avoid strain on the power supply lines when connecting the CLV490 with heater to the CDB420, please make sure to use the correct cable wire diameters for the incoming cables of the power supply to the CDB420 and to use corresponding fuses. Use only the screw terminals 1 to 4 for connecting the power supply. The input voltage connected to the screw terminals 1 and 2 is directly available on the screw terminals 3 and 4 for connecting the CLV490, independent of the S1 switch (Power).

Chapter 5.3 Connector pin assignment, Page 5-7 shows the pin assignments of the 15-pin plug and the open cable ends on the side of the CDB420.

5.2.4 Connections/cables for the CDM490 Connection Module

The CDM490 Connection Module is suitable for connecting **one CLV490 without/with heater** to peripherals (distribution function) and the power supply. The module can be used to establish a connection to the host (point-to-point), to integrate the device in a SICK CAN Scanner Network or in field bus systems. The module is available in one variant and can be operated without optional modules (see below) with an operating temperature to $-35\text{ }^{\circ}\text{C}$ ($-31\text{ }^{\circ}\text{F}$). For technical data see *Chapter 10.13.3 Accessories: Hoods, Page 10-75*.



Optional modules for building-in into the CDM490:

- CMP490 Power Supply Module in optional cover for supplying the CLV490 without heater directly from an AC power line
- CMC400 Connection Module Cloning for saving the parameters of the CLV490 externally
- CMD400 Connection Display Module in optional cover for representation of reading results and reading diagnosis data
- CMF400 Bus Modules (field bus gateways) for connecting the CLV490 to Profibus DP, DeviceNet or Ethernet TCP/IP

The CMP490 Power Supply Module can not be used if the CMD400 Display Module has always been built-in (or vice versa).

For detailed description of function and installation see the corresponding Fitting/Operating Instructions (see *Chapter , Page 10-84*).

Fig. 5-2 shows the connection principle of the CDM490.

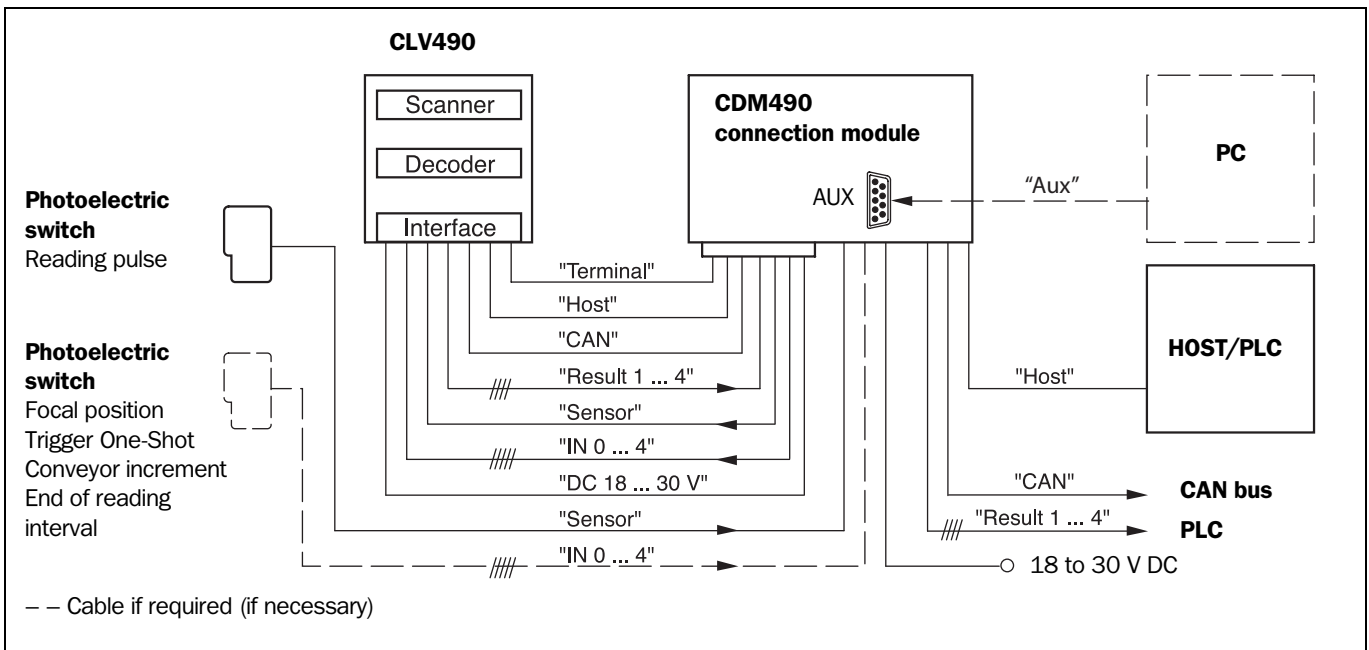

Fig. 5-2: Block diagram: Connection of the CLV490 to the CDM490 connection module



The procedures for connecting and configuring the connection module are described in the "CDM490 Connection Module" *Operating Instructions* (order no. 8010005, German/English).

Note Diagrams showing you how to connect the CDM490 Connection Module are also available in the "CLV Connect" PC program. This software is available on the "Manuals & Software" CD-ROM, which is included in the scope of delivery of the CLV490. The software can also

be downloaded from the SICK home page (www.sick.com) at "Service&Support/Download-pool". It can be called up using a standard HTML browser (e. g. Internet Explorer™).

Connecting the CLV490 to the CDM490

a) CLV490 without heater

The following connection cables **without** connector cover for the CLV490 can be used:

2 x no. 2020302 (3 m (3.84 ft)) or 2 x no. 2021815 (10 m (32.8 ft)).

Pin assignment identical to device connection of the CLV490.

The cables can be extended to 10 m (32.8 ft) (auxiliary interface: RS 232!).

The following connection cables **with** connector cover for the CLV490 can be used:

No. 2020307 (3 m (3.84 ft)).

b) CLV490 with heater:

The following connection cables **with** connector cover for the CLV490 can be used:

No. 2030065 (3 m (3.84 ft)) or no. 2031034 (10 m (32.8 ft)).

The cables must **not** be extended! If longer cables are required, the entire power supply system (Pin 1/Pin 5) must be connected with a wire cross-section of at least 0.75 mm² (approx. 20 AWG) with a maximum length of 10 m (32.8 ft).

Note To avoid strain on the power supply lines when connecting the CLV490 with heater to the CDM490, please make sure to use the correct cable wire diameters for the incoming cables of the power supply to the CDM490 and to use corresponding fuses. Use only the screw terminals 1 to 4 for connecting the power supply. The input voltage connected to the screw terminals 1 and 2 is directly available on the screw terminal 3 and 4 for connecting the CLV490, independent of the S1 switch (Power).

[Chapter 5.3 Connector pin assignment, Page 5-7](#) shows the pin assignments of the 15-pin plug connections and the open cable ends on the side of the CDM490.

5.2.5 Connections/cables for a non-SICK power pack

For connecting the CLV490 to a non-SICK power pack cables with open ends on the side of the power pack are available.

a) CLV490 without heater:

The following connection cables **without** connector cover for the CLV490 can be used:

No. 2020303 (3 m (3.84 ft)) and no. 2020264 (3 m (3.84 ft)).

Pin assignment identical to device connection of the CLV490.

The cables can be extended to 10 m (32.8 ft) (auxiliary interface: RS 232!).

The following connection cables **with** connector cover for the CLV490 can be used:

No. 2020981 (3 m (3.84 ft)) or no. 2021267 (3 m (3.84 ft)).

b) CLV490 with heater:

The following connection cables **with** connector cover for the CLV490 can be used:

No. 2021267 (3 m (3.84 ft)).

The cable can be used with temperatures up to max. -50 °C (-58 °F) if the CLV490 is stationary and the cables are not moved. If the cables are moved due to changes in the position of the CLV490, the temperature must not drop below max. -40 °C (-40 °F).

5.3 Connector pin assignment

5.3.1 Terminals on the CLV490

Device plug: "Host/Term" connection

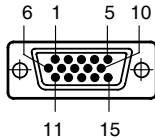

Pin	Signal	Function
1 ¹⁾	V _s	Supply voltage
2	RxD (RS 232), Auxiliary	Auxiliary interface (receiver)
3	TxD (RS 232), Auxiliary	Auxiliary interface (transmitter)
4	Term (RS 422/485)	Termination host interface
5	GND	Ground
6	RD+ (RS 422/485), Host	Host interface (receiver+)
7	RD- (RS 422/485), Host RxD (RS 232), Host	Host interface (receiver-)
8	TD+ (RS 422/485), Host	Host interface (transmitter+)
9	TD- (RS 422/485), Host TxD (RS 232), Host	Host interface (transmitter-)
10	CAN H	CAN interface 1 (IN/OUT)
11	Reserved	-
12	CAN2 H	CAN interface 2 (IN/OUT)
13	CAN2 L	CAN interface 2 (IN/OUT)
14	Reserved	-
15	CAN L	CAN interface 1 (IN/OUT)
Housing	-	Shield

1) Pin 1 is jumpered with Pin 1 of the "I/O" connection in the CLV490

Table 5-3: Pin assignment of the 15-pin D Sub HD "Host/Term" plug

Device socket: "I/O" connection

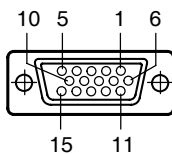

Pin	Signal	Function
1 ¹⁾	V _s	Supply voltage
2	IN 1	Switching input (trigger for focus control)
3	Sensor	Switching input (external reading pulse)
4	Result 1	Switching output, variable function
5	GND	Ground
6	IN 0	Switching input (trigger for focus control)
7	IN 2	Switching input (trigger for focus control)
8	Result 2	Switching output, variable function
9	INGND	Common ground for all inputs
10	Result 3	Switching output, variable function
11	IN 3	Switching input, variable function
12	IN 4	Switching input, variable function
13	I2C SDA	I2C Bus (for external parameter memory)
14	I2C SCL	I2C Bus (for external parameter memory)
15	Result 4	Switching output, variable function
Housing	-	Shield

1) Pin 1 is jumpered with Pin 1 of the "Host/Term" connection in the CLV490

Table 5-4: Pin assignment of the 15-pin D Sub HD "I/O" socket

CLV490 without heater on CDB420

**5.3.2 Cable no. 2027046 (connector cover)
Cable no. 2030023 (connector cover with parameter memory)**

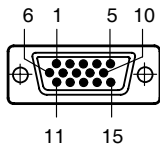
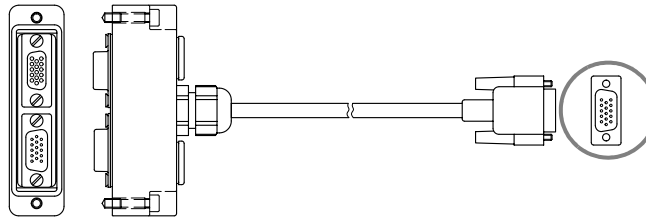

Pin assignment of 15-pin D Sub HD cable plug:

Signal	15-pin plug	Connector cover	
		15-pin plug	15-pin socket
V _s	1	–	1
RxD (RS 232), Aux	2	–	2
TxD (RS 232), Aux	3	–	3
IN 0 (Sensor 2)	4	6	–
GND	5	–	5
RD+ (RS 422/485), Host	6	–	6
RD– (RS 422/485), Host RxD (RS 232), Host	7	–	7
TD+ (RS 422/485), Host	8	–	8
TD– (RS 422/485), Host TxD (RS 232), Host	9	–	9
CAN H	10	–	10
CAN L	11	–	15
Result 1	12	4	–
Result 2	13	8	–
Sensor (Sensor 1)	14	3	–
INGND	15	9	–
Shield	Housing	Housing	

Table 5-5: Pin assignment: 15-pin D Sub HD plug of the cable no. 2027046/no. 2030023

The signals "IN 1" to "IN 4", "Result 3" to "Result 4" and "Term (RS-422/485)" are not available.

**CLV490 without heater
on CDM490**

5.3.3 Cable no. 2020307 (connector cover with parameter memory)

Pin assignment of 15-pin D Sub HD cable plug ("Host/Term" connection):

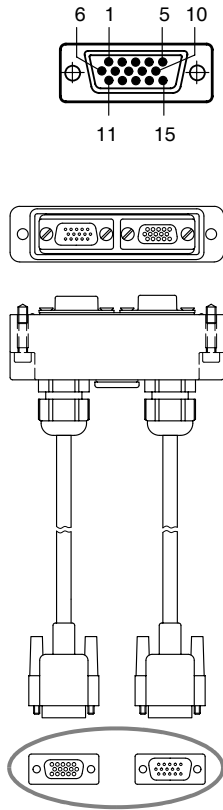

Signal	15-pin plug	Connector cover 15-pin socket
V _s	1	1
RxD (RS 232), Aux	2	2
TxD (RS 232), Aux	3	3
Term (RS 422/485)	4	4
GND	5	5
RD+ (RS 422/485), Host	6	6
RD- (RS 422/485), Host RxD (RS 232), Host	7	7
TD+ (RS 422/485), Host	8	8
TD- (RS 422/485), Host TxD (RS 232), Host	9	9
CAN H	10	10
Reserved	11	11
CAN2 H	12	12
CAN2 L	13	13
Reserved	14	14
CAN L	15	15
Shield	Housing	Housing

Table 5-6: Pin assignment: 15-pin D Sub HD plug of the cable no. 2020307

Pin assignment of 15-pin D Sub HD cable socket ("I/O" connection):

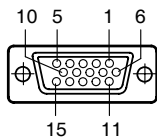

Signal	15-pin socket	Connector cover 15-pin plug
V _s	1	1
IN 1	2	2
Sensor	3	3
Result 1	4	4
GND	5	5
IN 0	6	6
IN 2	7	7
Result 2	8	8
INGND	9	9
Result 3	10	10
IN 3	11	11
IN 4	12	12
I2C SDA	13	–
I2C SCL	14	–
Result 4	15	15
Shield	Housing	Housing

Table 5-7: Pin assignment: 15-pin D Sub HD socket of the cable no. 2020307

CLV490 with heater on CDB420

5.3.4 Cable no. 2033126/2033127 (connector cover with parameter memory)

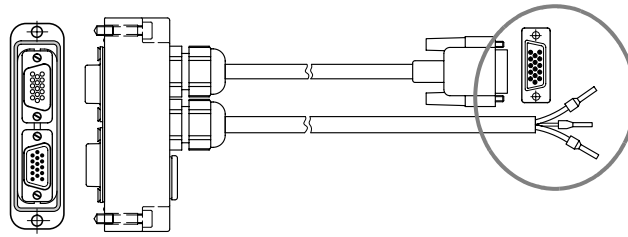

Pin assignment of 15-pin D Sub HD cable plug:

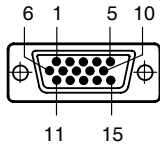

Signal	15-pin plug	Connector cover	
		15-pin plug	15-pin socket
V _s	1	–	–
RxD (RS 232), Aux	2	–	2
TxD (RS 232), Aux	3	–	3
IN 0 (Sensor 2)	4	6	–
GND	5	–	5
RD+ (RS 422/485), Host	6	–	6
RD– (RS 422/485), Host RxD (RS 232), Host	7	–	7
TD+ (RS 422/485), Host	8	–	8
TD– (RS 422/485), Host TxD (RS 232), Host	9	–	9
CAN H	10	–	10
CAN L	11	–	15
Result 1	12	4	–
Result 2	13	8	–
Sensor (Sensor 1)	14	3	–
INGND	15	9	–
Shield	Housing	Housing	

Table 5-8: Pin assignment: 15-pin D Sub HD plug of the cable no. 2033126/no. 2033127

Open end (power supply):

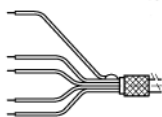

Signal	Wire	Ferrules	Connector cover	
			15-pin plug	15-pin socket
V _s	1	red	1	1
GND	2	black	5	5
Shield	3	grey	Housing	

Table 5-9: Pin assignment: open end of the cable no. 2033126/no. 2033127

The signals "IN 1" to "IN 4", "Result 3" to "Result 4" and "Term (RS-422/485)" are not available.

**CLV490 with heater
on CDM490**

5.3.5 Cable no. 2030065/2031034 (connector cover with parameter memory)

Pin assignment of 15-pin D Sub HD cable plug ("Host/Term" connection):

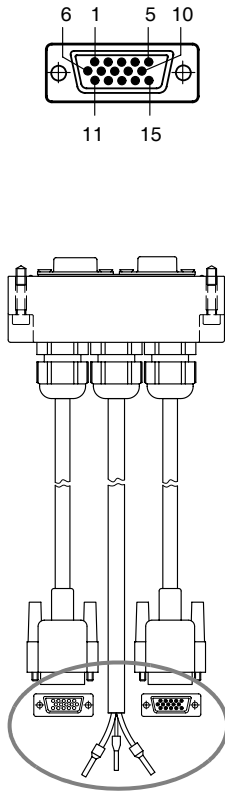

Signal	15-pin plug	Connector cover 15-pin socket
V _s	1	–
RxD (RS 232), Aux	2	2
TxD (RS 232), Aux	3	3
Term (RS 422/485)	4	4
GND	5	–
RD+ (RS 422/485), Host	6	6
RD– (RS 422/485), Host RxD (RS 232), Host	7	7
TD+ (RS 422/485), Host	8	8
TD– (RS 422/485), Host TxD (RS 232), Host	9	9
CAN H	10	10
Reserved	11	11
CAN2 H	12	12
CAN2 L	13	13
Reserved	14	14
CAN L	15	15
Shield	Housing	Housing

Table 5-10: Pin assignment: 15-pin D Sub HD plug of the cable no. 2030065/no. 2031034

Pin assignment of 15-pin D Sub HD cable socket ("I/O" connection):

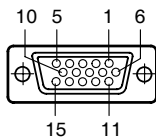

Signal	15-pin socket	Connector cover 15-pin plug
V _s	1	–
IN 1	2	2
Sensor	3	3
Result 1	4	4
GND	5	5
IN 0	6	6
IN 2	7	7
Result 2	8	8
INGND	9	9
Result 3	10	10
IN 3	11	11
IN 4	12	12
I2C SDA	13	–
I2C SCL	14	–
Result 4	15	15
Shield	Housing	Housing

Table 5-11: Pin assignment: 15-pin D Sub HD socket of the cable no. 2030065/no. 2031034

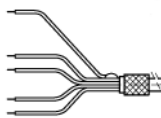
Open end (power supply):

Signal	Wire	Ferrules	Connector cover	
			15-pin plug	15-pin socket
V _s	1	red	1	1
GND	2	black	5	5
Shield	3	grey	Housing	

Table 5-12: Pin assignment: open end of the cable no. 2030065/no. 2031034

**CLV490 without heater
on power pack**

5.3.6 Cable no. 2020303

Pin assignment of 15-pin D Sub HD socket/open end ("Host/Term" connection):

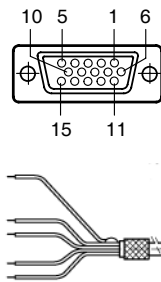

Signal	15-pin socket	Wire color
V _s	1	red
RxD (RS 232), Aux	2	white
TxD (RS 232), Aux	3	brown
Term (RS 422/485)	4	violet
GND	5	blue
RD+ (RS 422/485), Host	6	green
RD- (RS 422/485), Host RxD (RS 232), Host	7	yellow
TD+ (RS 422/485), Host	8	grey
TD- (RS 422/485), Host TxD (RS 232), Host	9	black
CAN H	10	grey-pink
Reserved	11	red-blue
CAN2 H	12	white-green
CAN2 L	13	brown-green
Reserved	14	white-yellow
CAN L	15	yellow-brown
Schirm	Housing	orange

Table 5-13: Pin assignment: 15-pin D Sub HD socket/wire colors of cable no. 2020303

**CLV490 without heater
on power pack**

5.3.7 Cable no. 2020264

Pin assignment of 15-pin D Sub HD plug/open end ("I/O" connection):

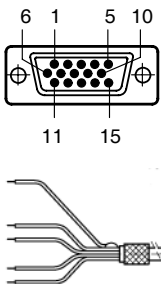

Signal	15-pin plug	Wire color
V _s	1	red
IN 1	2	white
Sensor	3	brown
Result 1	4	violet
GND	5	blue
IN 0	6	green
IN 2	7	yellow
Result 2	8	grey
INGND	9	black
Result 3	10	grey-pink
IN 3	11	red-blue
IN 4	12	white-green
I2C SDA	13	brown-green
I2C SCL	14	white-yellow
Result 4	15	yellow-brown
Shield	Housing	orange

Table 5-14: Pin assignment: 15-pin D Sub HD plug/wire colors of cable no. 2020264

**CLV490 without heater
on power pack**

5.3.8 Cable no. 2020981 (connector cover with parameter memory)

Cable 1, open end ("Host/Term" connection):

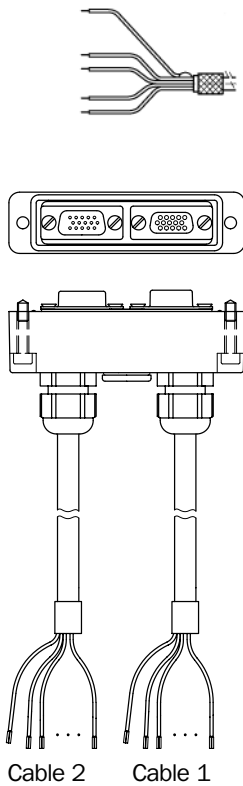

Signal	Wire color	Connector cover 15-pin socket
V _s	red and pink	1
RxD (RS 232), Aux	white	2
TxD (RS 232), Aux	brown	3
Term (RS 422/485)	violet	4
GND	blue and grey-brown	5
RD+ (RS 422/485), Host	green	6
RD- (RS 422/485), Host RxD (RS 232), Host	yellow	7
TD+ (RS 422/485), Host	grey	8
TD- (RS 422/485), Host TxD (RS 232), Host	black	9
CAN H	grey-pink	10
Reserved	red-blue	11
CAN2 H	white-green	12
CAN2 L	brown-green	13
Reserved	white-yellow	14
CAN L	yellow-brown	15
Shield	orange	Housing

Table 5-15: Wire colors of cable no. 2020981, cable 1 ("Host/Term" connection)

Cable 2, open end ("I/O" connection):

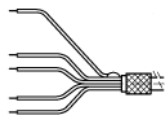

Signal	Wire color	Connector cover 15-pin plug
V _s	red and pink	1
IN 1	white	2
Sensor	brown	3
Result 1	violet	4
GND	blue and grey-brown	5
IN 0	green	6
IN 2	yellow	7
Result 2	grey	8
INGND	black	9
Result 3	grey-pink	10
IN 3	red-blue	11
IN 4	white-green	12
Reserved	–	13
Reserved	–	14
Result 4	yellow-brown	15
Shield	orange	Housing

Table 5-16: Wire colors of cable no. 2020981, cable 2 ("I/O" connection)

CLV490 with/without heater on power pack

5.3.9 Cable no. 2021267 (connector cover)

Cable 1, open end (connection for data and function interfaces):

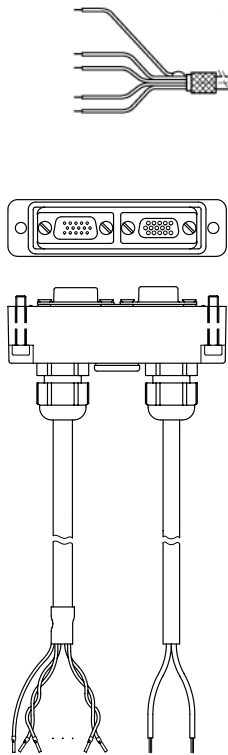

Cable 1 Cable 2

Signal	Wire color	Connector cover	
		15-pin plug	15-pin socket
IN 1	white	2	–
Sensor	brown	3	–
Result 1	green	4	–
IN 0	yellow	6	–
IN 2	grey	7	–
Result 2	pink	8	–
INGND	blue	9	–
Result 3	red	10	–
IN 3	black	11	–
IN 4	violet	12	–
Result 4	grey-pink	15	–
RxD (RS 232), Aux	red-blue	–	2
TxD (RS 232), Aux	white-green	–	3
Term (RS 422/485)	brown-green	–	4
RD+ (RS 422/485), Host	white-yellow	–	6
RD– (RS 422/485), Host RxD (RS 232), Host	yellow-brown	–	7
TD+ (RS 422/485), Host	white-grey	–	8
TD– (RS 422/485), Host TxD (RS 232), Host	grey-brown	–	9
Shield	orange	Housing	

Table 5-17: Wire colors of cable no. 2021267, cable 1 (connection for data and function interfaces)

Cable 2, open end (connection for power supply):

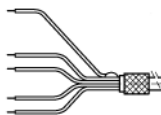

Signal	Wire color	Connector cover	
		15-pin plug	15-pin socket
V _s	red	–	1
GND	black	–	5

Table 5-18: Wire colors of cable no. 2021267, cable 2 (connection for power supply)

The signals of the CAN interface (CAN H, CAN L, CAN2 H, CAN2 L) are not available.

5.4 Preparations for electrical installation

5.4.1 Requirements for the host interface

The host interface of the CLV490 can be operated as an RS 422/485 or an RS 232 interface. [Table 5-19](#) shows the recommended maximum cable lengths as a function of the selected data transfer rate.

Interface type	Transfer rate	Distance from host
RS 232	Up to 19,200 bd 38,400 to 57,600 bd	Max. 10 m (32.8 ft) Max. 3 m (9.84 ft)
RS 422/485 ¹⁾	Max. 38,400 bd Max. 57,600 bd	Max. 1,200 m (3,936 ft) Max. 500 m (1,640 ft)

¹⁾ with suitable line termination according to specifications

Table 5-19: Maximum cable lengths between the CLV490 and host

- To prevent interference, do not lay the cables parallel with power supply and motor cables over long distances, e. g. in cable ducts.

5.4.2 Supply voltage

The CLV490 requires a supply voltage of 18 to 30 V DC for operation without a heater and 24 V DC +20 %/–10 % for operation with a heater (functional extra-low voltage in accordance with IEC 364-4-41). The functional extra-low voltage can be generated by using a safety transformer pursuant to IEC 742.

The power consumption of the individual types is as follows:

Type	Voltage	Scanning method	Heater	Power consumption ¹⁾	Connection module
CLV490-0010/-2010/-6010 CLV490-1010/-3010/-7010	18 to 30 V DC 18 to 30 V DC	Line scanner Line scanner with oscillating mirror	No No	11 W (typ.)/max. 16 W 13 W (typ.)/max. 18 W	CDB420 or CDM490
CLV490-0011/-2011/-6011 CLV490-1011/-3011/-7011	24 V DC +20 %/–10 %	Line scanner Line scanner with oscillating mirror	Yes Yes	75 W (typ.)/max. 90 W 75 W (typ.)/max. 100 W	CDB420 or CDM490

¹⁾ switching outputs not connected

Table 5-20: Power consumption of the CLV490

Via the CDB420 or CDM490 Connection Module the CLV490 without heater is supplied with 18 to 30 V DC, the CLV490 with heater is supplied with 24 V DC +20 %/–10 %. If the CMP 490 Power Supply Module in the CDM490 is used for the CLV490 without heater, the input voltage is 100 to 250 V AC/50 to 60 Hz.

Power-up delay

The selected device number (default: 1) affects the power-up delay of the device. This is useful if a large number of CLV490 (e. g. in the SICK CAN Scanner Network) are to be supplied from one power source. [Table 5-21](#) contains a list of the available intervals.

Device number GN	Power-up delay	Device number GN	Power-up delay
1; 11; 21; 31	0 ms	6; 16; 26	2,000 ms
2; 12; 22	400 ms	7; 17; 27	2,400 ms
3; 13; 23	800 ms	8; 18; 28	2,800 ms
4; 14; 24	1,200 ms	9; 19; 29	3,200 ms
5; 15; 25	1,600 ms	10; 20; 30	3,600 ms

Table 5-21: Power-up delay as a function of the device number GN



Tip The device number can be selected on the DEVICE CONFIGURATION tab in the "CLV-Setup" program.

5.4.3 Non-SICK Power supply unit/connections without the Connection Module

Power output

If an non-Sick Power supply unit is used, it must be capable of providing the following voltage and power values:

- For CLV490 without heater: 18 to 30 V DC, min. 20 W continuous power output
- For CLV490 with heater: 24 V DC +20 %/–10 %, min. 100 W

The non-Sick Power supply unit must provide the functional extra-low voltage in accordance with IEC 364-4-41.

The output circuit must be reliably electrically isolated from the input circuit. To do so, use a safety isolating transformer pursuant to IEC 742.

Wire cross-section

The wire cross-section for the power supply (Pin 1/Pin 5) should be at least 0.15 mm² (approx. 26 AWG) or 0.75 mm² (approx. 20 AWG) for CLV490 with heater, with a max. length of 10 m (32.8 ft).

5.5 Electrical installation procedure

5.5.1 Individual steps

- Connect the power supply
- Connect the host interface
- Connect the PC (connect the auxiliary interface)
- Connect the "Sensor" and "IN 0" to "IN 4" switching inputs
- Connect the "Result 1" to "Result 4" switching outputs

5.5.2 Tools

- Tool
- Digital measuring device (current/voltage measurement)

5.5.3 Connecting the supply voltage

a) SICK CDB420 or CDM490 Connection Module

If the CLV490 is powered via the SICK Connection Modules using the cables no. 2027046, no. 2030023 or no. 2020307 the supply voltage does not have to be wired separately.

Using the cables with open ends no. 2033126, no. 2033127, no. 2030065, or no. 2031034, the supply voltage must be wired separately at the screw terminal strips in the connection module.

Connecting the CLV490 without connector cover:

1. Make sure that the power supply to the connection module is switched off.
2. Connect the "Host/Term" and "I/O" connections on the CLV490 to the corresponding connections on the CDM490 Connection Module using two cables no. 2020302 or no. 2021815 and secure them tightly on both sides.

Connecting the CLV490 with connector cover/connector cover with parameter memory:

1. Connect the connector cover of the cable no. 2027046, no. 2030023, no. 2033126, or no. 2033127 to the "Host/Term" and "I/O" connections on the CLV490 and secure it tightly.
2. Connect the free 15-pin cable plug to the corresponding socket on the CDB420 Connection Module and secure them tightly.
For the cable no. 2033126 or no. 2033127, lead additionally the cable with open end through one of the cable glands and connect it to the screw terminals 3, 4, and 6.

– or –

1. Connect the connector cover of the cable no. 2020307, no. 2030065, or no. 2031034 to the "Host/Term" and "I/O" connections on the CLV490 and secure it tightly.
2. Connect the free 15-pin cable connections to the corresponding connections on the CDM490 Connection Module and secure them tightly.
For the cable no. 2030065 or no. 2031034, lead additionally the cable with open end through one of the cable glands and connect it to the screw terminals 3, 4, and 6.

The data and function interfaces of the CLV490 are connected to the Connection Module.



See also the Fitting Instructions for the "*Cold-resistant cable no. 2033126/no. 2033127*" (order no. 8010971, German/English) used for CDB420 respectively the Fitting Instructions for the "*Cold-resistant cable no. 2030065/no. 2031034*" (order no. 8010972, German/English) used for CDM490.

b) Power supply via non-SICK Power pack

Connecting the CLV490 without connector cover:

1. Connect the cable socket on cable no. 2020303 on the "Host/Term" connection and screw it tightly into position.
2. Connect the cable plug on the cable no. 2020264 to the "I/O" connection and screw it tightly into position.
3. Connect the power supply to the red wire (Pin 1, V_S) and blue wire (Pin 5, GND) on cable no. 2020303. See also [Table 5-13, Page 5-13](#)

Connecting the CLV490 with connector cover/connector cover with parameter memory:

1. Connect the connector cover of the cable no. 2020981 or no. 2021267 to the "Host/Term" and "I/O" connections on the CLV490 and secure it tightly.
2. For the cable no. 2020981 connect the power supply to the red/pink wire (Pin 1, VS) and the blue/grey-brown wire (Pin 5, GND) of cable 1. See also [Table 5-15, Page 5-14](#). For the cable no. 2021267 connect the power supply to the red wire (Pin 1, VS) and the black wire (Pin 5, GND) of cable 2. See also [Table 5-18, Page 5-15](#).

The CLV490 is connected to the supply voltage.

5.5.4 Connecting the host interface

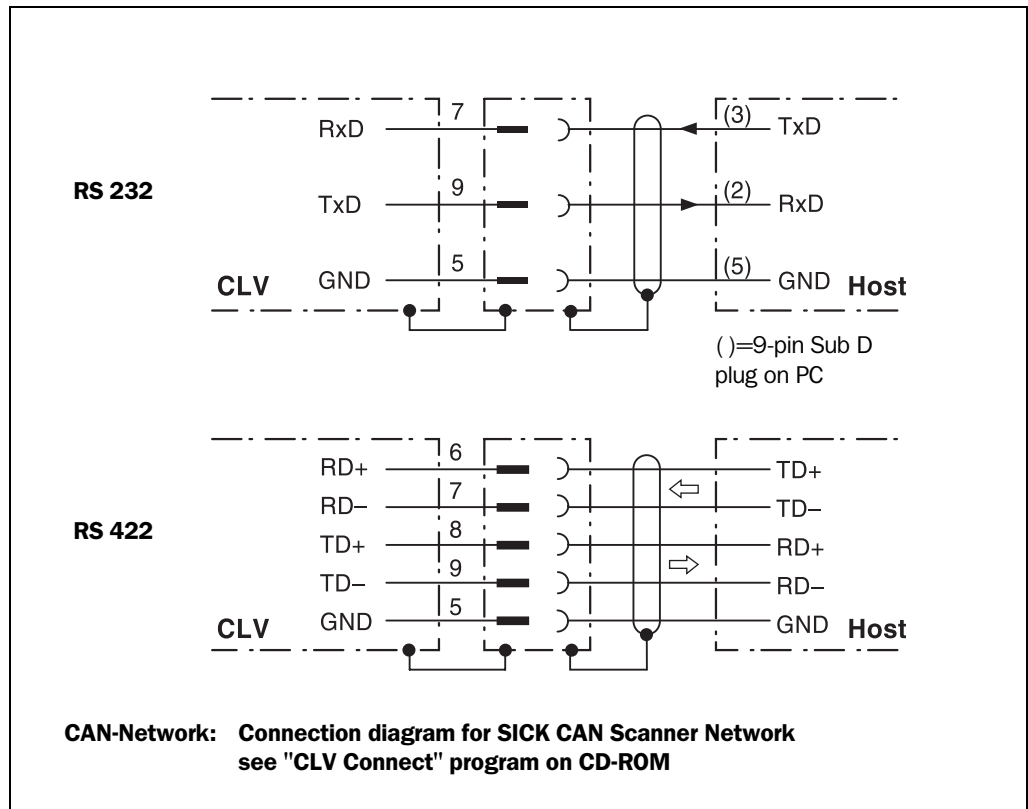

Fig. 5-3: Connecting the host interface



Risk of damage to the interface module

Electrical components in the CLV490 may be damaged if the host interface is connected incorrectly.

- Connect the host interface as shown in [Fig. 5-3](#).
- Check the connections carefully before you switch on the CLV490.
- Connect the host interface on the CLV490 to the host using shielded cables (EMC requirements). Ensure that the maximum cable lengths are not exceeded (see [Table 5-19, Page 5-16](#)).

Default In the default setting, the CLV490 communicates with the host via the host interface using the values shown in [Table 5-22](#).

Parameter	Value
Physical design	RS 422/485
Data transfer rate	9,600 bd
Data bits	8
Parity	None
Stop bits	1
Protocol	SICK (start character: STX, stop character: ETX, no request for repeat: none, timeout: 50 ms)

Table 5-22: Communication parameters for the host interface (default setting)



For connecting the host interface via the CDB420 or CDM490 Connection Module, see the Operating Instructions for the "CDB420 Connection Module" (no. 8010001, German/English) respectively the Operating Instructions for the "CDM490 Connection Module" (no. 8010005, German/English).

Terminating the RS 422 interface:

The interface can be terminated in the Connection Module. See the Operating Instructions for the "CDB420 or CDM490 Connection Modules".

Activating the RS 232 interface:



The RS 232 interface can be activated with the "CLV-Setup" program:

1. Choose the HOST INTERFACE tab.
2. Choose the RS 232 option from the HARDWARE drop-down list under DATA FORMAT.
3. Download the data to the CLV490 by clicking  in the toolbar.
The DOWNLOAD PARAMETERS dialog box is displayed.
4. Confirm the dialog box by choosing PERMANENT.
The CLV490 uses the RS 232 version of the host interface.

Tip The communication parameters can be changed, if necessary, on the HOST INTERFACE tab. To do so, change the values under DATA FORMAT and INTERFACE PROTOCOL.

5.5.5 Connecting the CAN interface

Connecting the CAN Interface 1 and configuring the CLV490 to use the device in the SICK-specific CAN Scanner Network or in a CANopen network see the Operating Instructions "Application of the CAN interface" (no. 8009180, English edition).

5.5.6 Connecting the PC

The CLV490 is operated and configured with the PC-based "CLV-Setup" program. In order to do so, you must connect the device to the PC via the auxiliary interface (auxiliary interface). Unlike the host interface, the auxiliary interface has a permanent data format and a fixed data transfer rate. Fig. 5-4 shows how the auxiliary interface is connected. The cable length should not be more than 10 m (32.8 ft).

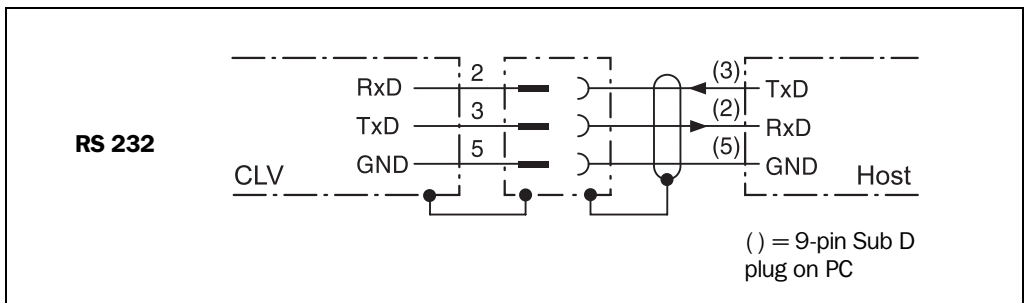

Fig. 5-4: Connecting the auxiliary interface

1. Switch off the PC and power supply to the CDB420 or CDM490 Connection Module.
2. Connect the PC to the internal, 9-pin "Aux" plug on the Connection Module.
To do so, use a 3-core RS 232 data cable (null modem cable), e. g. no. 2014054 (RxD and TxD crossed).

– or –

Without the SICK Connection Module:
Connect the PC as shown in Fig. 5-4.

3. Switch on the PC and power supply to the SICK Connection Module.
4. Set the communication parameters (see [Chapter 10.6.3 Starting CLV-Setup](#), [Page 10-46](#)).



Tip

In the default configuration, the auxiliary interface outputs the reading result in reading diagnosis mode.

You can change the operating mode to MONITOR HOST INTERFACE, to MONITOR HOST INTERFACE 2, AUXILIARY INPUT or EXTERNAL DATA STRING INPUT on the AUXILIARY INTERFACE tab in the "CLV-Setup" program.

5.5.7 Connecting the "Sensor" switching input

If a reading procedure is to be triggered on the CLV490 by an external sensor, the reading pulse sensor must be connected to the "Sensor" switching input. This trigger type is selected in the default setting of the CLV490. [Fig. 5-5](#) shows the connections for the "Sensor" switching input. [Table 5-23](#) contains the characteristic data for this input.

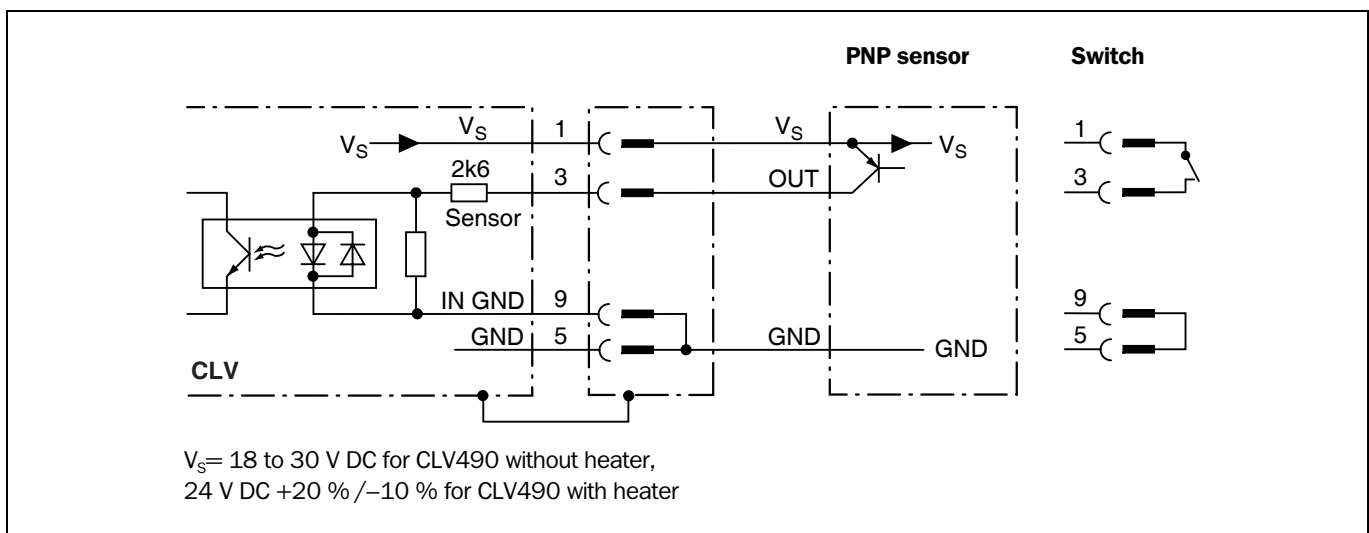

Fig. 5-5: Connections of the "Sensor" switching input

- Connect the reading pulse sensor as shown in [Fig. 5-5](#).

Switching mode	Current at the input starts the reading interval on the CLV490. (default: active high, debouncing: 20 to 30 ms (standard))
Properties	<ul style="list-style-type: none"> - optodecoupled, non-interchangeable - can be connected to PNP output on a sensor
Electrical values	Low: $-30 \text{ V} \leq V_i \leq +2 \text{ V}$ High: $+7 \text{ V} \leq V_i \leq +13 \text{ V}$

Table 5-23: Characteristic data of the "Sensor" switching input



Tip

You can change the switching mode (polarity, debouncing, response for first pulse after power-up) of the "SENSOR" switching input on the DEVICE CONFIGURATION tab in the "CLV-Setup" program.

- Click the READING TRIGGER PARAMETERS button. Enter the values in the dialog box displayed. Perform a download to the CLV490.



For connecting the switching input via the CDB420 or CDM490 Connection Module, see the Operating Instructions for the "CDB420 Connection Module" (no. 8010001, German/English) respectively the Operating Instructions for the "CDM490 Connection Module" (no. 8010005, German/English).

Note An external pulse is not required for Percentage Evaluation mode.

5.5.8 Connecting the "IN 0" to "IN 4" switching inputs

If the Autofocus function is not used and the CLV490 dynamic focus control function is to be triggered by external sensors, the sensors are connected to the five inputs "IN 0" to "IN 4". Together with the internal assignment table, these can be used to configure a maximum of 32 switching states for up to 8 distance configurations. The dynamic focus control function is selected for all inputs by default.

Additional function "IN 3":

The "IN 3" input can also be used as a trigger source for the One-Shot function of the oscillating mirror.

Additional function "IN 4":

The input "IN 4" can also be used as:

- A trigger source for the One-Shot function of the oscillating mirror
- An input for a belt increment signal in reading mode "Tracking" and/or for separating bar codes of the same symbology with identical content
- A trigger source for the end of reading interval

In this case, a maximum of 16 switching statuses can be used for dynamic focus control.

Fig. 5-6 shows the connections for the "IN 0" to "IN 4" switching inputs. Table 5-24 shows the pin assignment on the CLV490. Table 5-25 contains the characteristic data for these inputs. Table 5-26 shows the input combinations based on the distance configurations. The interaction of the switching input functions is shown in Table 5-27, Page 5-25

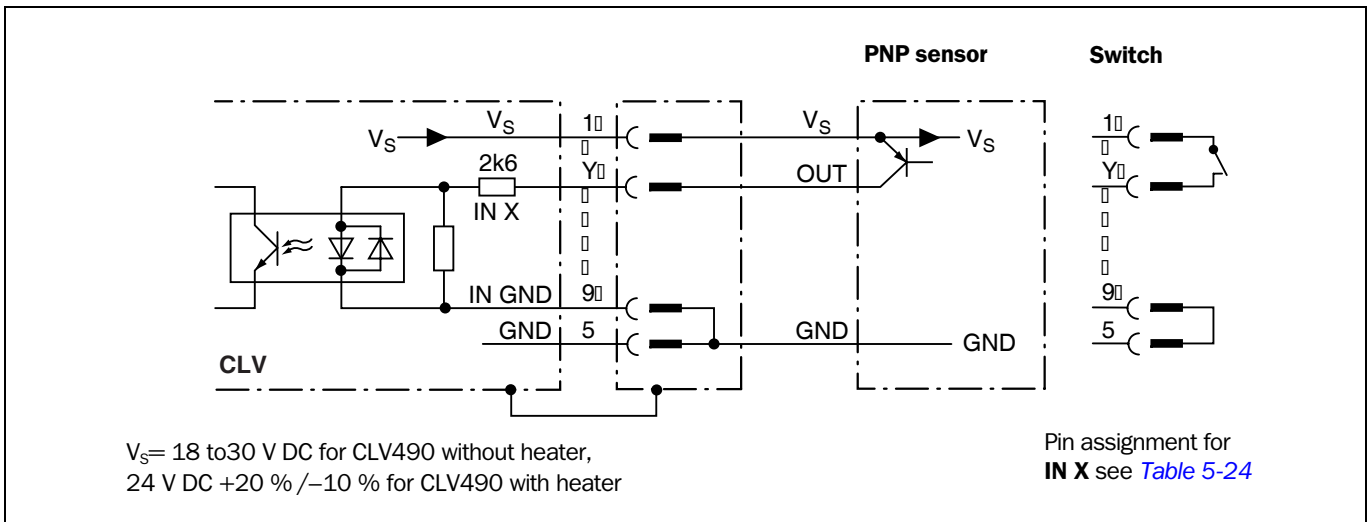

Fig. 5-6: Connections of the "IN 0" to "IN 4" switching inputs

Note In the **CDB420** Connection Module only the signals of the "Sensor" and "IN 0" switching inputs can be connected using the terminal strips.

Input "IN X"	CLV490 "I/O" connection Pin Y
IN 0	Pin 6
IN 1	Pin 2
IN 2	Pin 7
IN 3	Pin 11
IN 4	Pin 12

Table 5-24: Pin assignment for "IN 0" to "IN 4" switching inputs

- Connect the sensors as shown in [Fig. 5-6](#).



For connecting the switching inputs via the CDB420 or CDM490 Connection Module, see the Operating Instructions for the "CDB420 Connection Module" (no. 8010001, German/English) respectively the Operating Instructions for the "CDM490 Connection Module" (no. 8010005, German/English).

Function	Trigger source for dynamic focus control "IN 3" alternative: – trigger source for One Shot on oscillating mirror "IN 4" alternative: – trigger source for One Shot on oscillating mirror – belt increment input – trigger source for end of reading interval Default setting "IN 3" and "IN 4": dynamic focus control
Switching mode	Active when input energized (high)
Properties	– Optodecoupled, non-interchangeable – Can be connected to PNP output on a sensor
Electrical values	Low: $-30\text{ V} \leq V_I \leq +2\text{ V}$ High: $+7\text{ V} \leq V_I \leq +13\text{ V}$

Table 5-25: Characteristic data of the "IN 0" to "IN 4" switching inputs

Switching inputs		Content Assignment Table Distance Config. ²⁾	
Logic state ¹⁾ "IN 4" to "IN 0" inputs	Assignment table index	Default setting	Example: Photoelectric switches (bright switching)
0 0 0 0 0	N 1	DC 1	DC 6
0 0 0 0 1	N 2	DC 2	DC 5
0 0 0 1 0	N 3	DC 3	DC 4
0 0 0 1 1	N 4	DC 4	DC 4
0 0 1 0 0	N 5	DC 5	DC 3
0 0 1 0 1	N 6	DC 6	DC 3
0 0 1 1 0	N 7	DC 7	DC 3
0 0 1 1 1	N 8	DC 8	DC 3
0 1 0 0 0	N 9	DC 8	DC 2
0 1 0 0 1	N 10	DC 8	DC 2
0 1 0 1 0	N 11	DC 8	DC 2
0 1 0 1 1	N 12	DC 8	DC 2
0 1 1 0 0	N 13	DC 8	DC 2
0 1 1 0 1	N 14	DC 8	DC 2
0 1 1 1 0	N 15	DC 8	DC 2
0 1 1 1 1	N 16	DC 8	DC 2
1 0 0 0 0	N 17	DC 8	DC 1
1 0 0 0 1	N 18	DC 8	DC 1
1 0 0 1 0	N 19	DC 8	DC 1
1 0 0 1 1	N 20	DC 8	DC 1

Table 5-26: Dynamic focus control: switching inputs/distance configuration assignment table

Switching inputs		Content Assignment Table Distance Config. ²⁾	
Logic state ¹⁾ "IN 4" to "IN 0" inputs	Assignment table index	Default setting	Example: Photoelectric switches (bright switching)
1 0 1 0 0	N 21	DC 8	DC 1
1 0 1 0 1	N 22	DC 8	DC 1
1 0 1 1 0	N 23	DC 8	DC 1
1 0 1 1 1	N 24	DC 8	DC 1
1 1 0 0 0	N 25	DC 8	DC 1
1 1 0 0 1	N 26	DC 8	DC 1
1 1 0 1 0	N 27	DC 8	DC 1
1 1 0 1 1	N 28	DC 8	DC 1
1 1 1 0 0	N 29	DC 8	DC 1
1 1 1 0 1	N 30	DC 8	DC 1
1 1 1 1 0	N 31	DC 8	DC 1
1 1 1 1 1	N 32	DC 8	DC 1

1) 1 = energized (active); 0 = deenergized (inactive)
 2) Distance configuration (DC): data record for focus position

Table 5-26: Dynamic focus control: switching inputs/distance configuration assignment table (contd.)

Parameter settings of switching inputs		Effects
"IN 3"	"IN 4"	
Focus control ¹⁾	Focus control ¹⁾	"IN 3" switches the focus position in combination with "IN 0" to "IN 2" and "IN 4"
Focus control ¹⁾	One shot	"IN 4" triggers the one shot "IN 3" switches the focus position in combination with "IN 0" to "IN 2"
Focus control ¹⁾	Increment counter	"IN 4" receives increment signals "IN 3" switches the focus position in combination with "IN 0" to "IN 2"
Focus control ¹⁾	End of reading interval	"IN 4" triggers the end of reading interval "IN 3" switches the focus position in combination with "IN 0" to "IN 2"
One shot	Focus control ¹⁾	"IN 0" to "IN 2" switch the focus position "IN 3" triggers the one shot "IN 4" has no effect
One shot	One shot	"IN 4" triggers the one shot "IN 0" to "IN 2" switch the focus position "IN 3" has no effect
One shot	Increment counter	"IN 0" to "IN 2" switch the focus position "IN 3" triggers the one shot "IN 4" receives increment signals
One shot	End of reading interval	"IN 0" to "IN 2" switch the focus position "IN 3" triggers the one shot "IN 4" triggers the end of reading interval

1) depending on the assignment table

Table 5-27: Combination of the functions of the "IN 0" to "IN 4" switching inputs



Tip

The function assigned to the "IN 3" and "IN 4" input can be modified on the DEVICE CONFIGURATION tab in the "CLV-Setup" program.

- Click the FUNCTION IN 3 and FUNCTION IN 4 drop-down list and choose the required function.
Perform a download to the CLV490.

5.5.9 Connecting the "Result 1" to "Result 4" switching outputs

The four switching outputs can be assigned different functions for outputting result statuses independently of each other. If the assigned event occurs during the reading procedure, the corresponding switching output becomes live at the end of the reading pulse for the selected pulse duration. The pulse duration can be set individually for each output.

The "Read Result" LED is linked to the "Result 2" output and lights up in Reading mode for the selected pulse duration and function of the result status display (default: Good Read, 100 ms).

Fig. 5-7 shows the connections for the "Result 1" to "Result 4" switching outputs.

Table 5-28 shows the pin assignment on the CLV490. Table 5-29 contains the characteristic data for these outputs. The four outputs have the same characteristic data.

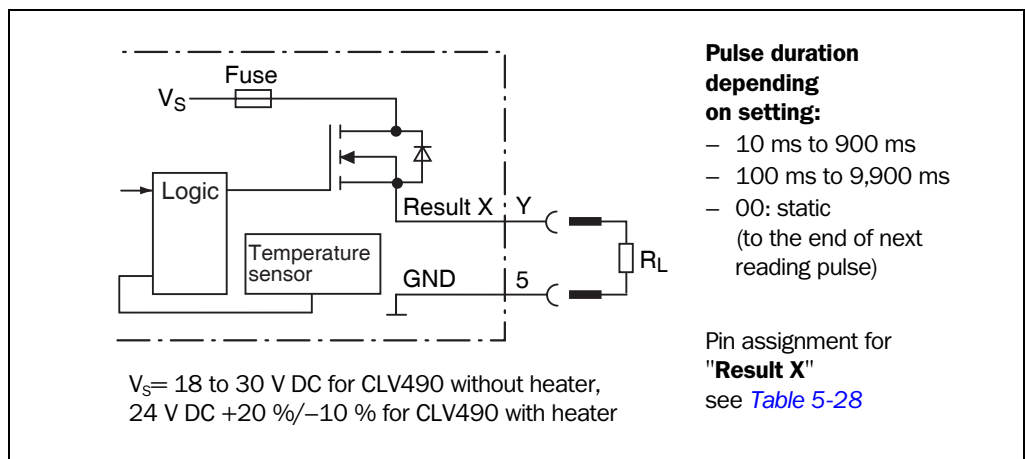

Fig. 5-7: Connections of the "Result 1" to "Result 4" switching outputs

Output "Result X"	CLV490 "I/O" connection Pin Y
Result 1	Pin 4
Result 2	Pin 8
Result 3	Pin 10
Result 4	Pin 15

Table 5-28: Pin assignment for "Result 1" to "Result 4" switching outputs

➤ Connect the outputs as shown in Fig. 5-7.

Note In the **CDB420** Connection Module only the signals of the "Result 1" and "Result 2" switching outputs can be connected using the terminal strips.

Switching mode	PNP-switching with respect to the supply voltage V_s
Properties	The current in the event of a short-circuit is limited to 0.7 A
Function assignment (default)	"Result 1": Device Ready (static), polarity: not inverted "Result 2": Good Read (100 ms), polarity: not inverted "Result 3": No Ready (100 ms), polarity: not inverted "Result 4": Match 1 (100 ms), polarity: not inverted
Electrical values	$0\text{ V} \leq V_o \leq 30\text{ V}$ Guaranteed: $V_o \leq V_s \leq 1.3\text{ V}$ with $I_o \leq 100\text{ mA}$ $I_o \leq 100\text{ mA}$

Table 5-29: Characteristic data of the "Result 1" to "Result 4" switching outputs

Note If the "Device Ready" function is chosen, the CLV490 outputs a static pulse in Reading mode.



For connecting the switching outputs via the CDB420 or CDM490 Connection Module, see the Operating Instructions for the "*CDB420 Connection Module*" (no. 8010001, German/English) respectively the Operating Instructions for the "*CDM490 Connection Module*" (no. 8010005, German/English).

**Tip**

The output function, pulse duration (timer), and polarity of the signals can be changed on the DEVICE CONFIGURATION tab in the "CLV-Setup" program.

- Click the RESULT OUTPUTS Parameter button.
Enter the values in the dialog box displayed.
Perform a download to the CLV490.

Recommendation

- To check the switching functions using a high-impedance digital voltmeter, connect a load to the outputs to prevent incorrect voltage values/switching statuses from being displayed.

Notes:

6 Operation

6.1 Overview of steps for starting up the CLV490

- Start up the CLV490 with the factory default settings (quick start).
With this configuration, the CLV490 can be operated without being connected to a PC.
- Connect the PC. See [Chapter 5.5.6 Connecting the PC, Page 5-21](#) and [Chapter 10.6 Installing and operating the "CLV-Setup" program, Page 10-43](#).
- Configure (parameterize) the CLV490 for the application.



6.2 Default settings

[Table 6-1, Page 6-2](#) and [Table 6-2](#) contain an overview of the factory default settings for the CLV490. The default parameters are such that the CLV490 can be put into operation either straight away or following a few minor adjustments. A PC does not need to be connected to start up the CLV490 with the default settings.

The default settings are stored permanently both in the ROM of the CLV490 and in the CLV-Setup database. They can be loaded to the RAM of the CLV490 at any time and displayed in the tabs of the "CLV-Setup" program.

Displaying and printing out a complete set of default settings in CLV-Setup:



1. To save the current settings in the parameter set:
Choose FILE and SAVE AS, and enter a file name in the dialog box that appears. CLV-Setup saves the current settings in a configuration file with the extension "*.scl".
2. Click  in the toolbar.
CLV-Setup loads the default settings from its internal database and displays them in the tabs.
3. Click  in the toolbar.
The PRINT FILE dialog box is displayed.
4. If desired, a comment can be entered in the input field for the header of the printout. Confirm the entry with OK. The PRINT dialog box for configuring the printer then is displayed.
5. Make the appropriate entries in the dialog box and confirm these with OK.
CLV-Setup prints out the complete set of default settings in the form of a table. The header contains the company and user names that were entered during the CLV-Setup installation routine.

6.2.1 Default settings of the line scanner CLV490 (all variants)

Parameter	Default setting
Decoder	SMART/standard
Active codes types	Code 39, 2/5 Interleaved, Code 128
Code length	Freely assignable (2/5 Interleaved: interval 4 to 50 characters)
Start/stop ratio	Automatic
Min./max. reading angle	5/ 95 RA
No. of multiple reads	3
Min./max. no. codes	1
Scanning frequency	800 Hz
Distance measurement	Active
Background	Default (2,200 mm (86.7 in) along entire distance profile)
Autofocus mode	Min. distance
Range	400 to 2,200 mm (15.8 to 86.7 in)
Scan angle	-27° to +27°
Focus control trigger	Autofocus, switchover immediately (synchronously)
Reading pulse source	Start: "Sensor" switching input (active: high); end: "Sensor" switching input
"IN 0" to "IN 4" switching inputs	Focus position changeover (without meaning for autofocus function)
"Sensor" switching input	Start and end of reading pulse (level: active high), debouncing 20 to 30 ms
Switching outputs	Not inverted; pulse duration: 100 ms
Status output function	Result 1: Device Ready (static); Result 2: Good Read; Result 3: No Read; Result 4: Match 1
CLV490 arrangement	Stand-alone
Read result output	Host interface
Device number	1
Start option	Load the parameter set of the external parameter memory
Host interface (type)	RS 422/485
Protocol	NAK; start character: STX, stop character: ETX
Transmission rate	9 600 bd
Data format	8 data bits, no parity, 1 stop bit
Output format	Good Read: Header: blank, Code Info/Separator: blank, Splitter: blank, Terminator: blank Reading data on No Read: output: yes, contents: Code Info/Separator and Error string Error string: NOREAD
Output sorting	In accordance with reading angle
Output time	Read result: end of the read interval Code Info/Separator: after code
Test string	Not activated
Auxiliary interface	RS 232, 9 600 bd, 8 data bits, no parity, 1 stop bit (values cannot be changed)
Function	Reading diagnosis

Table 6-1: Extract: Default parameter settings of the line scanner CLV490-0010/-0011

6.2.2 Default settings of the line scanner with oscillating mirror CLV490 (all variants)

Default settings as for line scanner CLV490, but with the following additional parameters:

Parameter	Default setting
Oscillating amplitude	±40 CW (corresponds to an angle of deflection of -20° to +20°)
Operating mode	Oscillating with fixed amplitude, mode independent of reading pulse trigger
Oscillating frequency	1 Hz
Fixed position	50 CW (corresponds to an angle of deflection of 105°)

Table 6-2: Extract: Default parameter settings of the line scanner with oscillating mirror CLV490

6.3 Quick start

A PC need not be connected when the CLV490 is operated with the factory default settings. Code 39, 2/5 Interleaved, and Code 128 are the default code types enabled (free code length, 2/5 Interleaved: interval 4 to 50 characters).

6.3.1 Starting up the CLV490 with the factory default settings

1. Connect the CLV490 as followed:
 CDB420 Connection Module: use the cable no. 2027046 (connector cover, IP 65).
 Alternatively, connect the CLV490 via the cable no. 2030023 (connector cover with external parameter memory, IP 65).
 CDM490 Connection Module: use two cables no. 2020302.
 Alternatively, connect the CLV490 via the cable no. 2020307 (connector cover with external parameter memory, IP 65).
2. Connect the reading pulse sensor (e. g. photoelectric reflex switch) to the "Sensor (1)" switching input of the CLV490 via the CDB420 or CDM490 (see [Chapter 5.5.7 Connecting the "Sensor" switching input, Page 5-22](#)).
3. Switch on the power supply of the CDB420 or CDM490.
 The CLV490 starts. The "Device Ready" LED lights up.
 The "Result 1" ("Device Ready") output switches.

CLV490 with external parameter memory in the connector cover connected :

If no **CMC400 parameter memory module** is available in the **CDB420 or CDM490 Connection Module** the CLV490 will operated as followed:

If an external parameter memory in the connector cover containing a corresponding parameter set is connected to the CLV490, the "Device Ready" LED blinks for 10 s when the device starts up correctly and then lights up constantly.

If the external parameter memory in the connector cover is empty, the CLV490 copies its parameter set to the external parameter memory. Then the "Device Ready" LED lights up. The CLV490 is ready for operation.

If a **CMC400** is available in the **CDB420 or CDM490** the CLV490 cancels the function of the external parameter memory in the connector cover. The CLV490 supports the CMC400 from firmware V 3.30 on.

Line scanner with oscillating mirror:

In the default setting, the CLV490 deflects the scan line around the position CW = 50 with a frequency of 1 Hz and an oscillating amplitude of $\pm 20^\circ$ (± 40 CW). 50 CW correspond to a deflection angle below 105° .

4. Start the reading pulse: block the light path of the photoelectric switch or close the switch. The "Sensor" LED lights up. The CLV490 switches the laser diode on and the red scan line appears.
5. Present the bar code pattern ([Fig. 6-1, Page 6-4](#)) to the CLV490 at the reading distance specified in [Table 6-3](#).
The scan line must not hit any object in a distance closer to the CLV490 than the represented bar code (default setting: autofocus mode "Minimum distance").
6. Align the bar code in such a way that the red scan line is almost at a 90° angle to the bars (line scanner) or that the red scan line sweeps the bars at a 90° angle when it is deflected (oscillating mirror).
7. End the reading pulse: unblock the light path of the photoelectric switch or open the switch. The "Sensor" LED is extinguished. The CLV490 switches the laser diode off. The CLV490 confirms that the bar code was read successfully (the "Read Result" LED lights

up for 100 ms). The "Result 2" ("Good Read") output is switched for a duration of 100 ms.

The CLV490 can now be operated with the factory default settings.

The device can be switched off without the configuration data being lost as no changes have been made to the parameter set.



Fig. 6-1: Bar code pattern (Code 39; module width 0.35 mm (11.8 mil); Print ratio 2:1)

Device type	Scanning method	Reading distance
CLV490 (all variants)	Line scanner	approx. 1,000 mm (39.4 in)
CLV490 (all variants)	Line scanner with oscillating mirror	approx. 1,000 mm (39.4 in)

Table 6-3: Reading distances for default settings

6.4 Configuring (parameterization) the CLV490

The CLV490 adapts to the reading situation locally with the configuration. The read, evaluation and output characteristics can, therefore, be parameterized as required on the basis of the factory default settings or an application-specific CLV490 parameter set that has already been created.

The CLV490 supports two different configuration methods:

- Configuration via the "CLV-Setup" program
(parameter values are set via the serial interface)
- Configuration via command strings
(parameter values are set via the serial interface).

See [Chapter 10.7 Configuring a CLV490 with command strings, Page 10-53](#).

In the Parameterization mode, the CLV490 outputs no reading result.



6.4.1 Configuring the CLV490 via the user interface of CLV-Setup

To be able to use CLV-Setup, a PC has to be connected and the program installed on it. The procedure for connecting the PC to the CLV490 is described in [Chapter 5.5.6 Connecting the PC, Page 5-21](#). The procedures for installing and starting the "CLV-Setup" program and for starting and operating the user interface are described in the Appendix ([Chapter 10.6 Installing and operating the "CLV-Setup" program, Page 10-43](#)).

Transferring a parameter set between CLV-Setup and the CLV490

Upload

When the CLV490 is being parameterized, CLV-Setup runs in the **offline mode**. To be able to modify the current parameter set of the CLV490, this first has to be loaded to CLV-Setup from the CLV490. This procedure is referred to as an **upload** ("Upload from CLV" in the CLV490 menu or [F3] key) during which CLV-Setup always loads a complete copy of the current CLV490 parameter set. This parameter set remains unchanged until it is overwritten by CLV-Setup.

With the help of the **context menu** (right mouse button), only the parameter just edited can be loaded ("Upload parameter") or from version 3.6 all parameters of one tab or one dialog box ("Upload parameters of this view") from the CLV490's memory (RAM).

Download

Changes made to the current parameter set in CLV-Setup do not take effect until the parameter set has been transferred to the CLV490. CLV-Setup always sends a copy of the complete parameter set to the CLV490, i. e. all of the existing parameter values in the CLV490 are overwritten. The procedure for transferring and saving the parameter values in the CLV490 is referred to as a **download** ("Download to CLV" in the CLV490 menu or [F4] key).

With the help of the **context menu** (right mouse button), only the parameter just edited ("Download parameter") or from version 3.6 all parameters of one tab or one dialog box ("Download parameters of this view") will be **temporarily** loaded into the CLV490's memory (RAM). To finish the parametrization done by this way all parameters must be download again to the CLV490 with the **"Permanent"** option.

Loading a complete CLV490 parameter set (upload)

- Click  in the toolbar or press [F3] key.
CLV-Setup loads the current CLV490 parameter set from the RAM of the CLV490 to its database and displays the values in the tabs.
The "Device Ready" LED is extinguished during the upload.

If the "CLV-Setup" program does not recognize parameters transferred during the upload, it outputs a warning message. Unknown parameters can be edited in the EXTRAS tab by following the conventions for command strings. When the parameter set is then saved, these parameters are also saved.

Transferring and saving a complete CLV490 parameter set (download)

1. Click  in the toolbar or press [F4] key.
The "Device Ready" LED is extinguished.
CLV-Setup copies the parameter set to the RAM of the CLV490. The DOWNLOAD PARAMETERS dialog box with the storage options is then displayed.
PERMANENT: CLV-Setup copies the parameter record to the RAM **and** to the EEPROM of the CLV490.
TEMPORARY: CLV-Setup copies the parameter record to the RAM only. The changes are lost when the CLV490 supply voltage is switched off.
2. Confirm the dialog box with the desired storage option.
The "Device Ready" LED lights up again.

The new parameter set is stored in the CLV490 either permanently or temporarily dependent of the selected option.

CLV490 with external parameter memory

If the parameter set was downloaded and stored **permanently**, CLV-Setup opens a further dialog box for adjusting the parameter set in the external memory, if the start option is set to START WITH EXTERNAL PARAMETERS.

- Choose the COPY NOW INTERNAL PARAMETER SET TO EXTERNAL MEMORY option.
CLV-Setup then instructs the CLV490 to copy the new parameter set to the external memory. The "Device Ready" LED lights up again.

The internal and external parameter sets are now identical.

See also [Chapter 10.3.5 Adjusting the parameter set in the external parameter memory \(connector cover\) after it has been downloaded to the CLV490, Page 10-37.](#)

Saving the parameter set in CLV-Setup

1. To save the modified parameter set as a new configuration file in CLV-Setup, or to overwrite an existing file, choose FILE and SAVE AS.
The SAVE AS ... dialog box is then displayed.
2. Enter the file name in the dialog box (file name extension "*.scl") and confirm the entry.
The new parameter set is now stored in CLV-Setup in the subdirectory "data".

6.4.2 Function of the tabs in CLV-Setup (overview)



Reading Configuration

This tab and further dialog boxes are used to set the following:

- Scanning frequency
- Start/stop ratio
- Reading area (reading angle limits or three-dimensional reading space when the conveyor is running)
- Autofocus mode (object distance measurement, preference focus distance, delay of focus change, depth of field optimization, autofocus space, delimitations, extent of deflection)
- Reading distance configurations for event-controlled focus control (focus position, evaluation range of the scan line, assignment table)
- Trigger source for the focus control
- Adjustment to bar code quality characteristics, background (scattered print) and relative module width



Device Configuration

This tab and further dialog boxes are used to set the following:

- Device number
- Source of the Reading trigger mode
- Laser timeout
- Output time of the Reading result referred to the start of the reading interval
- Scanner position parameters (the position of the CLV490 in the area)
- Tracking parameters
- Object polling parameters
- Output filter of the reading result (host interface)
- Physical arrangement for data output via the host interface (stand-alone, master/slave)
- Functional assignment of the "IN 3" and "IN 4" switching inputs
- Functional assignments of the "Result 1" to "Result 4" switching outputs
- Start option for accessing the parameter set
- Match code



Code Configuration

This tab and further dialog boxes are used to set the following:

- Type of active decoder (SMART and/or standard decoder)
- Evaluation routines for individual code types
- Number of identical reads (multiple reads)
- Minimum and maximum number of bar codes to be read/output
- Start/Stop recognition mode
- Activation of the comparison of the reading angle for the separation of identical bar codes
- Special parameters of the SMART decoder (e. g. for OTS mode)

Recommendation

To enhance the reading reliability with fast applications, only activate those code types and code lengths that are actually relevant.



Host Interface

This tab and further dialog boxes are used to set the following:

- Destination of the read result data strings (host interface or CAN interface)
- Active physical interface (RS 422/485 or RS 232)
- Data format and transmission rate
- Data transmission protocol
- Start and stop characters of the interface protocol



Data Strings

This tab and further dialog boxes are used to set the following:

- Data output format of the host interface (telegram format)
- Constants and reading diagnosis data in the "Header", "Code info/separator", "Splitter" and "Terminator" blocks
- Arrangement of the "Code info/separator" blocks in the data string
- Output format for no reads and contents of the error string
- Test string function
- Output sequence and sort criteria for reading more than one bar code per reading pulse
- Format mask and its structure
- Output format of an external data string forwarded as reading result



Auxiliary Interface

This tab and further dialog boxes are used to change the following:

- Operating mode of the auxiliary interface

CAN Interface

This tab and the further dialog windows are used to change the following:

- CAN interface operating mode
- Data transfer rate
- Type of logical data connection of the connected CLV490
- Usage of the switch inputs/outputs of the CLV490 as CANopen Digital I/O



Oscillating Mirror

This tab is used to set the following:

- Operating mode of the oscillating mirror
- Oscillating frequency
- Angle of deflection (oscillating amplitude)
- Start of oscillating mode
- Trigger source for One-Shot

Fieldbus Gateway

This tab (and additional dialog boxes) are used to set the following:

- Data interface of the CLV490 to be connected to the gateway in the CDM490
- Type of fieldbus
- Special fieldbus parameters

X Extras

This tab is used to edit parameters that were not recognized by CLV-Setup after an upload.

Note CLV-Setup Online Help contains a detailed description of the functions of the parameters and their valid entries (see [Chapter 10.6.8 Online help – CLV-Setup Help, Page 10-50](#) for calling up Help).

6.4.3 Parameterizing example

For a simple application in start/stop mode, [Chapter 10.10 Discussion of a parameterization example, Page 10-60](#) in the appendix shows an example of the recommended procedure when parameterizing the CLV490. Otherwise, the general guidelines in the next chapter provide orientation during adaptation to the individual reading situation.

6.4.4 Guide to parameterization menu

Overview of parameterization steps

- a) Configuring the reading area
- b) Selecting the focus control mode
- c) Configuring the focus control
- d) Adjusting the optical read properties of the scanner
- e) Optional: configuring the oscillating mirror functions
- f) Configuring the reading mode
- g) Adjusting the laser timeout
- h) Adjusting the decoder's evaluation properties
- i) Adjusting the output properties (data, result status)
- j) Specifying the auxiliary interface function (auxiliary interface)
- k) Configuring the source of the parameter set for starting up
(only with external parameter memory)

When the CLV490 is switched on for the first time, it is started with **the factory default** settings. The following parameters must then be set:

a) Parameterizing reading area

Irrespective of the type of focus control, the reading area defines the area along the scan line in which the CLV490 always evaluates bar codes. In combination with the multiple focus position switchover/autofocus, this produces a vertical plane relative to the CLV490 (or a tunnel in the case of object tracking in conveyor mode). During evaluation, the CLV490 rejects any bar codes detected outside the defined area.

Condition: reading from above with line scanner

- **Reading angle limits:**

Simple delimitation of the reading area (circle segment) by restricting the active scan angle range without reference to a point of origin (Fig. 6-2). The scan angle range is max. $\pm 30^\circ$ for a line scanner and max. $\pm 25^\circ$ for a line scanner with oscillating mirror.

- **Reading space:**

Sharp delimitation of the active reading area by defining the area through which the object must pass in the circle segment. This produces a rectangular reading space with reference to a point of origin. For use in conveyor systems where the conveyor belts are very close to each other and the scan line partly extends over adjacent belts because the CLV490 is installed above the belt.

The position of the CLV490 in relation to the defined reading space and the point of origin must also be parameterized (scanner position and angular position).

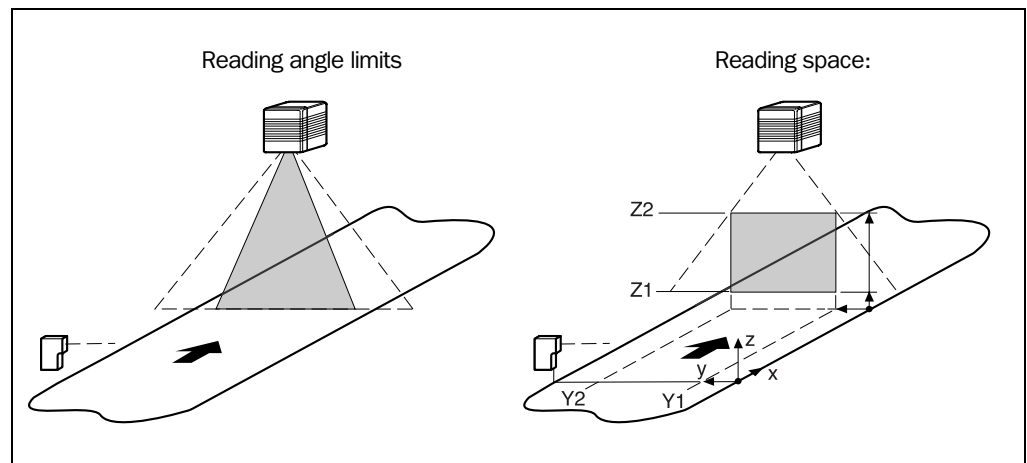

Fig. 6-2: Narrowing the reading space using limit values

Note In the case of the line scanner with oscillating mirror, the active deflection range of the oscillating mirror can also be restricted (CW value).

Action	Settings in CLV-Setup
Define reading angle limitations – and/or –	⇨ READING CONFIGURATION tab ⇨ READING AREA section ⇨ READING ANGLE LIMITS ⇨ DISTANCE CONFIGURATION button ⇨ DISTANCE CONFIGURATION tab – configuration 1: Minimum RA and Maximum RA <i>Oscillating mirror:</i> – additionally: Oscillating mirror amplitude CW
Define reading space	⇨ READING AREA section ⇨ READING AREA ⇨ READING SPACE PARAMETERS button – Right edge of conveyor (Y 1) – Left edge of conveyor (Y 2) – Level of conveyor (Z 1) – Maximum scanning height (Z 2) Define the CLV490 position referred to the reading space (point of origin): ⇨ DEVICE CONFIGURATION tab ⇨ SCANNER POSITION PARAMETERS button ⇨ ANGLES – alpha, beta and gamma ⇨ COORDINATES – x-, y- and z-coordinates

Table 6-4: Guide: Configuring the reading area

Note The minimum and maximum values for the active evaluation range of the scan line (reading angle limits) can be checked in the SHOW RA-LIMITS mode.
 See also [Chapter 6.5.5 Show RA-limits, Page 6-46](#).

Recommendation Don't configure the reading space if you use the free running mode in combination with a fixed focus position (fix focus mode). Restrict the reading space using the reading angle limits.

b) Selecting focus control mode

- Autofocus:**
 Using the periodic object distance measurement function, the CLV490 creates an up-to-date distance profile in its area of view with every 10th scan. From this profile, the CLV490 uses the selected autofocus mode, the parameterized limits of the autofocus area, and the taught-in background (optional) to automatically determine the required focus position for a detected object. The defined autofocus area should be within the limits of the parameterized reading area.
- Event-controlled focus control:**
 The CLV490 controls its focus position by means of object distance information, which it receives either externally via the switching inputs (reading from above: object height detection by means of photoelectric switches) and their assignment to parameterized distance configurations, or by means of command strings via the serial data interface (also with reference to distance configurations). In timer mode (search), the CLV490 changes its focus position step by step according to the parameterized number and sequence of distance configurations. The line scanner with oscillating mirror also uses – similar to the timer mode – its oscillating mirror reversal points at the maximum deflection points to trigger the switchover.

The time at which focusing occurs relative to the reading pulse can be selected for both types of focus control.

Action	Settings in CLV-Setup
Activate autofocus – or –	⇒ READING CONFIGURATION tab ⇒ FOCUS CONTROL section – Autofocus
Activate focus position switch-over (event-controlled) (selecting trigger source)	⇒ READING CONFIGURATION tab ⇒ FOCUS CONTROL section – Inputs/Serial <i>or</i> – Timer ⇒ TIMER <i>or</i> – Static/No trigger <i>Oscillating mirror:</i> – additionally: Oscillating mirror extrema

Table 6-5: Guide: Selecting the focus control mode

c) Parameterizing focus control

Autofocus

Condition: Reading from above

- Minimum distance:**
 Relative to its surroundings, the object is always located at the shortest distance from the CLV490. Example: object positioned directly on the conveyor belt without a container (tray, etc.) or interfering side boundaries
 Condition: only **one object** in the reading field during the reading interval.
- Differential background:**
 The background can be closer to the CLV490 than the object.
 Example: object in a container on the conveyor belt; the container wall is higher than the object (closer to the CLV490).
 Condition: only **one object** in the reading field during the reading interval.
- Differential background and tracking:**
 Same as the "Differential background" function, except that in each reading pulse **more than one object** can be located in the reading field at the same time. On the basis of the detected distances, the CLV490 assigns the required focus positions in its internal focus list to the objects and organizes the objects using a continuous increment in its object list. In this way, scanned bar-code information can be uniquely assigned to the individual objects. This is only available in the reading mode "Tracking" (internal tracking or reading mode "OTS trigger"), not in "Object polling" mode (one object only) of start/stop mode. For more detailed information, see also [Chapter A2. Tracking mode \(controlled by Increment\), Page 6-27.](#)

Explanation Background teach-in:

For autofocus modes "Differential background" and "Differential background and tracking", the CLV490 can also teach in the ambient background in its area of view (e.g. if interfering objects in the conveyor system project into the defined autofocus area) in order to improve the evaluation of the current distance profile. When doing so, the CLV490 adjusts – among other things – the measured background by 100 mm (3.9 in) in its direction to compensate any measurement inaccuracies.

The default background at a distance of 2,200 mm (86.7 in) is used in all other cases and, if necessary, the autofocus area is limited by means of the appropriate parameters. In this

case, CLV490 measurement inaccuracies must be taken into account when the rectangular autofocus space is defined.

Oscillating mirror:

When the background is being taught in, the behavior of the oscillating mirror depends on the selected mode (see [Chapter 6.5.4 Background teach-in, Page 6-44](#)).

Action	Settings in CLV-Setup
<p>1. Select autofocus mode</p> <p>– or –</p> <p>– or –</p>	<p>⇒ READING CONFIGURATION tab</p> <p>⇒ AUTOFOCUS section</p> <p>⇒ MODE</p> <p>– Minimum distance</p> <p>See also overview in Table 6-7, Page 6-15.</p> <hr/> <p>⇒ MODE</p> <p>– Differential background</p> <p>Define the scanner position referred to the conveyor belt: see Table 6-4, Page 6-11, reading space, scanner position</p> <p>Limit autofocus area: Define limit values and /or a rectangular autofocus area. Optionally teach in the background.</p> <p>⇒ Limit values and autofocus space: see 2. „Configure autofocus“, AUTO FOCUS LIMITS tab</p> <p>⇒ Teach in the background: see 3. „Teach-in background (optional)“</p> <p>See also overview in Table 6-7, Page 6-15.</p> <hr/> <p>⇒ MODE</p> <p>– Differential background and tracking</p> <p>Define the scanner position referred to the conveyor belt: see Table 6-4, Page 6-11, reading space, scanner position</p> <p>Limit autofocus area: Define limit values and /or a rectangular autofocus area. Optionally teach in the background.</p> <p>⇒ Limit values and autofocus space: see 2. „Configure autofocus“, AUTO FOCUS LIMITS tab</p> <p>⇒ Teach in the background: see 3. „Teach-in background (optional)“</p> <p>See also overview in Table 6-7, Page 6-15.</p>
<p>2. Configure autofocus</p>	<p>⇒ AUTOFOCUS PARAMETERS button</p> <p>⇒ AUTOFOCUS PARAMETERS tab</p> <p>⇒ AUTOFOCUS PREFERENCES tab</p> <p>– Default focus distance¹⁾ (default setting)</p> <p>⇒ AUTOFOCUS LIMITS PARAMETERS button</p> <p>⇒ AUTOFOCUS LIMITATION section</p> <p>– Min. and max. value</p> <p>⇒ SCAN ANGLE LIMITATION section</p> <p>– Min. and max. value</p> <p><i>Oscillating mirror:</i></p> <p>⇒ additionally: OSCILLATING ANGLE LIMITATION section</p> <p>– Min. and max. value</p>
<p>1) Typical for reading from above. The focus position is located slightly above the smallest object. In this way, if the CLV490 is mounted with its reading window opposite the conveying direction, it can continuously adjust (raise) the focus position on the front of approaching objects that are larger than the smallest object.</p>	

Table 6-6: Guide: Configuring the autofocus function (part 1)

Action	Settings in CLV-Setup
2. Configure autofocus	Additionally for autofocus mode "Differential background" and „Differential background and tracking“: <ul style="list-style-type: none"> ⇒ AUTOFOCUS SPACE section <ul style="list-style-type: none"> – Right edge of conveyor (Y 1) – Left edge of conveyor (Y 2) – Level of conveyor (Z 1) – Maximum scanning height (Z 2) ⇒ AUTOFOCUS OPTIMIZATION PARAMETERS button <ul style="list-style-type: none"> ⇒ DELAY OF FOCUS CHANGE section <ul style="list-style-type: none"> – Timeout – Hysteresis ⇒ DEPTH OF FIELD OPTIMIZATION section <ul style="list-style-type: none"> – Offset at minimum – Offset at maximum ⇒ "Distance measurement" section (default setting) <ul style="list-style-type: none"> – active – Source of distance information: internal/external – Smooth filter: active, length 3
3. Teach-in background (optional)	For autofocus mode "Differential background" and „Differential background and tracking“: <ul style="list-style-type: none"> ⇒ Menu CLV490 ⇒ DEVICE FUNCTIONS <ul style="list-style-type: none"> ⇒ Background <ul style="list-style-type: none"> – Teach-in Check taught-in background: <ul style="list-style-type: none"> ⇒ READING CONFIGURATION tab ⇒ AUTOFOCUS section <ul style="list-style-type: none"> ⇒ SHOW BACKGROUND²⁾ button Displaying online the actual background profile with focus level points: <ul style="list-style-type: none"> ⇒ Menu CLV490 <ul style="list-style-type: none"> ⇒ BACKGROUND ANALYSIS <ul style="list-style-type: none"> – Analysis: Autofocus
4. Select focus position switchover (referred to the start of the reading interval)	<ul style="list-style-type: none"> ⇒ READING CONFIGURATION tab ⇒ FOCUS CONTROL section <ul style="list-style-type: none"> ⇒ INPUTS/SERIAL/AUTOFOCUS <ul style="list-style-type: none"> – immediate or synchronous (default setting) or – latched
2) The CLV490 displays the taught-in background with the internal correction of 100 mm (3.9 in) but not the parameterized limits of the autofocus space.	

Table 6-6: Guide: Configuring the autofocus function (part 1) (contd.)

Note At a scanning frequency of 1,000 Hz, the typical response time for focus adjustment is 20 ms, or 30 ms if the entire range (between min. and max. focus position) is traversed. The CLV490 does not switch over the focus until the defined timeout has elapsed and the new focus position exceeds the parameterized hysteresis value relative to the old focus position. If the new focus position is within the hysteresis, the CLV490 does not switch over the focus.

Depth-of-field optimization with respect to the object and the purpose of depth-of-field optimization are described in [Chapter 3.2.1 Autofocus function, Page 3-7](#).

Overview: Autofocus functions

Parameter	Autofocus mode		
	Minimum distance	Differential background	Differential background and tracking
<i>Condition</i>	Only one object in the reading field during reading interval	Only one object in the reading field during reading interval	Several objects in the reading field during reading interval
1. Limitation values: autofocus limitation	✘	○	○
2. Limitation values: scan angle limitation	✘	○	○
<i>Oscillating mirror:</i> 3. Limitation values: oscillating angle limitation	✘	✘	✘
4. Limitation values: autofocus space	–	○	○
5. Teach-in background	–	○	○
6. Scanner position parameters: angle alpha, beta, gamma	–	✘	✘
7. Scanner position parameters: coordinates x, y, z	–	✘	✘
8. Tracking: Configure the mode (OTS trigger or internal tracking)	–	–	✘
9. Tracking parameters: Focus release point	–	–	✘
10. More than one bar code per object: Min. and max. number of codes	–	–	✘

✘: required ○: optional –: not required

Table 6-7: Configuring the autofocus function (part 2)

Fig. 6-3 shows a 3D example of how the autofocus area of the CLV490 is adjusted using the parameters "Limit values: scan angle limitation" and "Limit value: autofocus space".

Note If the required focus positions determined by the CLV490 are outside the defined autofocus area limits, the focus positions are not switched over (not even to the limit values).

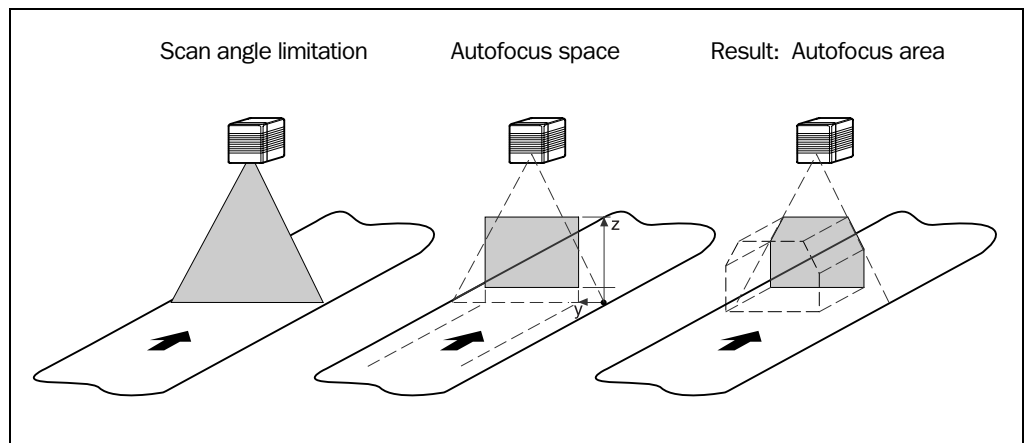

Fig. 6-3: Narrowing the autofocus range using limit values

Event-controlled focus position switchover (alternative)

Event-controlled focus position switchover can be used if the autofocus function does not provide the expected accuracy for the application. Event-controlled focus position switchover is required in the following cases, for example:

- Conveyed material with a black surface (e.g. vehicle tires)
The laser light emitted by the CLV490 is absorbed by the surface of the material, which means that the distance measurement may no longer be sufficiently accurate.
- Conveyed material with highly reflective surfaces (e.g. anti-static bags)
- Conveyed material with bar codes on the front edge in the conveying direction. At high conveyor speeds, the CLV490 can no longer adjust the focus in time.

Action	Settings in CLV-Setup
1. Set up distance configurations	<ul style="list-style-type: none"> ⇒ READING CONFIGURATION tab ⇒ READING AREA section ⇒ DISTANCE CONFIGURATION button <ul style="list-style-type: none"> ⇒ DISTANCE CONFIGURATION tab – Focus position <i>Oscillating mirror:</i> <ul style="list-style-type: none"> – additionally: Oscillating mirror amplitude CW ⇒ ASSIGNMENT TABLE tab <ul style="list-style-type: none"> – Index – Valid configurations <p>To restrict the reading area for all valid distance configurations proceed as described in Table 6-4, Page 6-11, reading angle limits</p>
2. Select focus position switchover (referred to the start of the reading interval)	<ul style="list-style-type: none"> ⇒ READING CONFIGURATION tab ⇒ FOCUS CONTROL sections <ul style="list-style-type: none"> ⇒ INPUTS/SERIAL/AUTOFOCUS <ul style="list-style-type: none"> – immediate or synchronous (default setting) or – latched (special application)
3. INPUTS/SERIAL trigger source: select function for "IN 3" and "IN 4" switching inputs	<ul style="list-style-type: none"> ⇒ DEVICE CONFIGURATION tab ⇒ ASSIGNMENT OF INPUTS section ⇒ IN 3 <ul style="list-style-type: none"> – Focus control ⇒ IN 4 <ul style="list-style-type: none"> – Focus control

Table 6-8: Guide: Configuring focus position switchover

d) Parameterizing optical reading characteristics

- Scanning frequency ⇒ READING CONFIGURATION tab ⇒ READING PARAMETERS section
- Blank zone ⇒ READING CONFIGURATION tab ⇒ READING PARAMETERS/START/STOP RATIO section
- Poor quality bar code print (e.g. small contrast or scattered print) ⇒ READING CONFIGURATION tab ⇒ CODE LABEL/BACKGROUND CHARACTERISTICS section
- If reading bar codes with small height (bar length) using the SMART decoder ⇒ CODE CONFIGURATION tab ⇒ DECODER section/SMART PARAMETERS button

e) Parameterizing oscillation mirror functions (optional)

Action	Settings in CLV-Setup
1. Choose "Oscillating with fixed amplitude" mode (identical amplitude for all distance configurations with event-controlled focus control) – or –	⇨ OSCILLATING MIRROR tab ⇨ OSCILLATING MIRROR section – Oscillating with fixed amplitude ⇨ OSCILLATING section – Frequency
2. Choose "Oscillating with variable amplitude" mode (amplitude can be chosen for each distance configuration with event-controlled focus control) – or –	⇨ OSCILLATING MIRROR tab ⇨ OSCILLATING MIRROR section – Oscillating with variable amplitude ⇨ OSCILLATING MODE section – Frequency ⇨ READING CONFIGURATION tab ⇨ AUTOFOCUS PARAMETERS button respectively Distance Configurations – Oscillating mirror amplitude CW
3. Choose "Fixed Position" mode – or –	⇨ OSCILLATING MIRROR tab ⇨ OSCILLATING MIRROR section – Fixed Position ⇨ FIXED POSITION section – Stationary Position (CW)
4. Choose "One-Shot" mode	⇨ OSCILLATING MIRROR tab ⇨ OSCILLATING MIRROR section – One-Shot ⇨ ONE-SHOT section ⇨ PHASE 1 – Mirror Speed – Start Position (CW) – Distance Configuration (no.) ⇨ PHASE 2 – Mirror Speed – Start Position (CW) – Distance Configuration (no.)
5. With One-Shot: choose trigger source	⇨ OSCILLATING MIRROR tab ⇨ ONE-SHOT section ⇨ TRIGGER MODE – Reading Trigger Pulse or – Switching input or – Serial interface
6. With One-Shot and trigger source "IN 3" or "IN 4": Choose function for switching input "IN 3" or "IN 4"	⇨ DEVICE CONFIGURATION tab ⇨ ASSIGNMENT OF INPUTS ⇨ IN 3 – One Shot or ⇨ IN 4 – One Shot ⇨ see also Table 5-27, Page 5-25
7. Choose activity of oscillating mode "Oscillating with ..."	⇨ OSCILLATING MIRROR tab ⇨ OSCILLATING MIRROR ACITVE section – Continuous or – during reading interval

Table 6-9: Guide: Configuring oscillating mirror functions

Note The OSCILLATE WITH VARIABLE AMPILTUDE operating mode can only be selected from amplitudes of min. ± 10 CW and an oscillating frequency of 0.4 Hz or higher.

The scan line must always sweep the neutral position (CW = 50). This means that oscillation is not possible in the range 60 CW to 80 CW, for example, but is possible in the range 40 CW to 80 CW.

Explanation of oscillating mirror functions

1. "Oscillating with fixed amplitude" mode

The oscillating mirror deflects the scan line up to the maximum angle of deflection of ± 40 CW (corresponds to $\pm 20^\circ$). Fig. 6-4 illustrates this mode when a bar code is read from above.

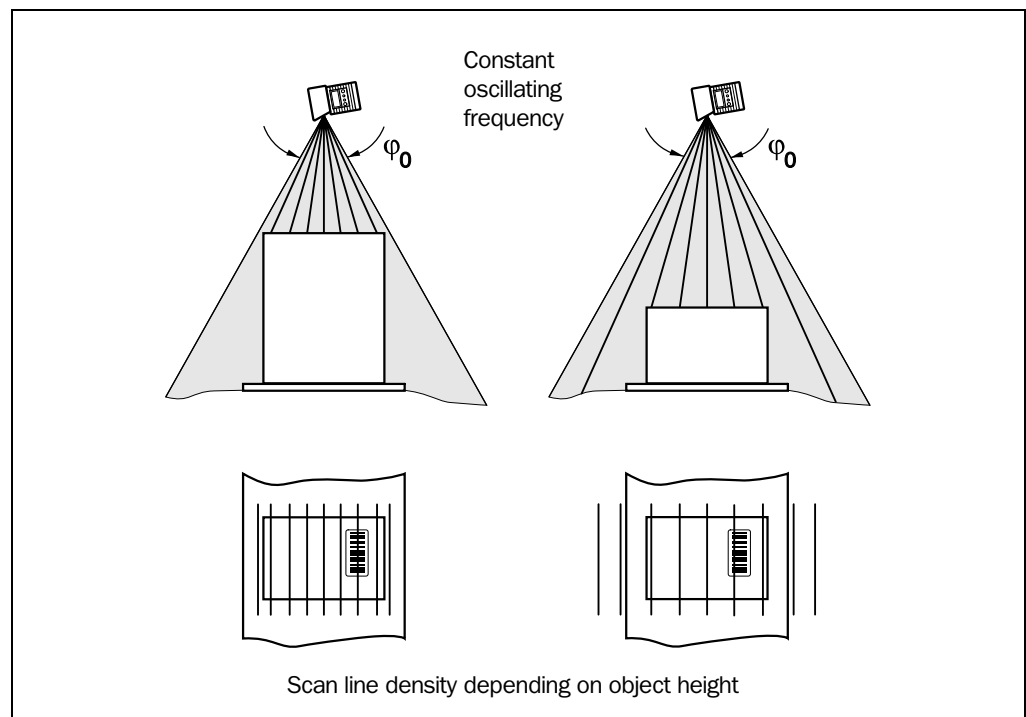

Fig. 6-4: Oscillating mirror: "Oscillating with fixed amplitude" mode

2. "Oscillating with Variable Amplitude" mode

The deflection range can be parameterized separately for each of the maximum of 8 distance configurations/focus positions. The minimum/maximum values that can be set for the deflection range for fast applications ensure that the scan line only sweeps areas that contain bar codes during the time available. This also ensures that the scan line density on the object is, for the most part, constant. Fig. 6-5 illustrates this mode when a bar code is read from above.

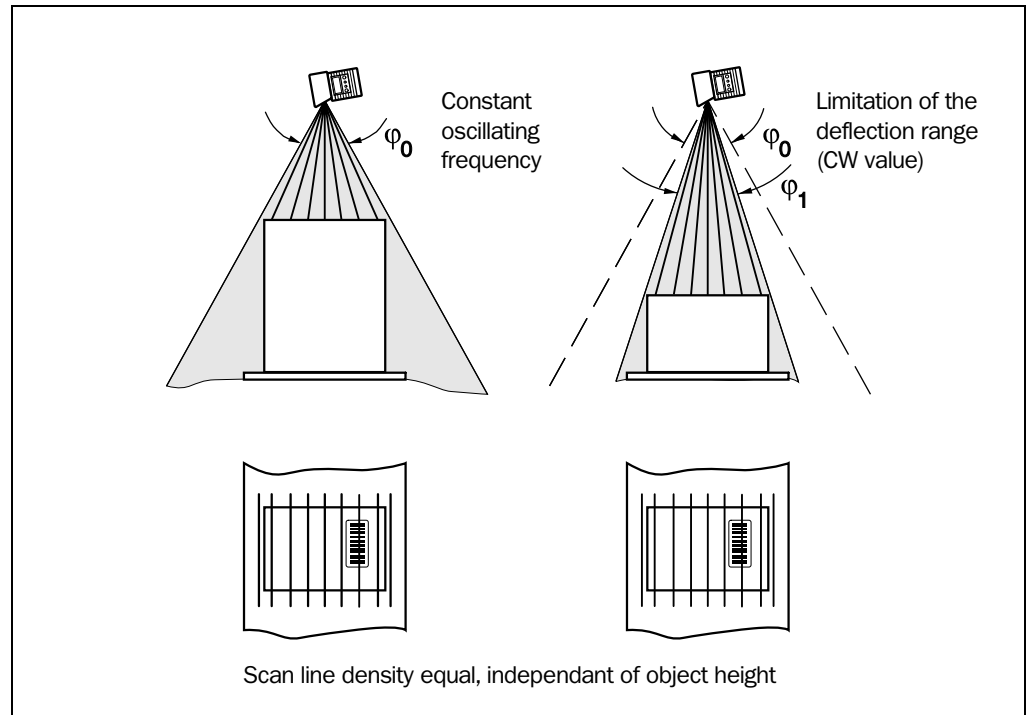

Fig. 6-5: Oscillating mirror: "Oscillating with variable amplitude" mode

3. "Fixed Position" mode

The CLV490 parks the oscillating mirror at the desired position. 10 CW corresponds to -20° , and 90 CW to $+20^\circ$ (see [Fig. 4-8, Page 4-6](#)). In the default setting, the fixed position is set to 50 CW (corresponds to an angle of deflection below 105°). The Oscillating mode is switched off.

4. "One-Shot" mode

In the "One-Shot" mode, the oscillating mirror only performs one specific oscillating movement per reading interval. This movement consists of a forward phase and a return phase. The start position of the scan line, the mirror speed and the valid distance configuration can be parameterized separately for each phase. The end position of the one phase forms the start position of the other phase. [Fig. 6-6](#) illustrates this mode with object tracking. During the forward phase, the front of the object that moves towards the oscillating mirror is swept once by the scan line from top to bottom in accordance with the conveyor speed. Multiple focus position switchovers are not necessary as the required reading range (DOF) is much smaller than with the line scanner. [Fig. 10-42, Page 10-57](#) explains how the start position and mirror speed are calculated for a given conveyor speed.

Possible trigger sources for One-Shot:

- "IN 3" or "IN 4" switching input
- Command string (via serial interface)
- Start of the reading interval

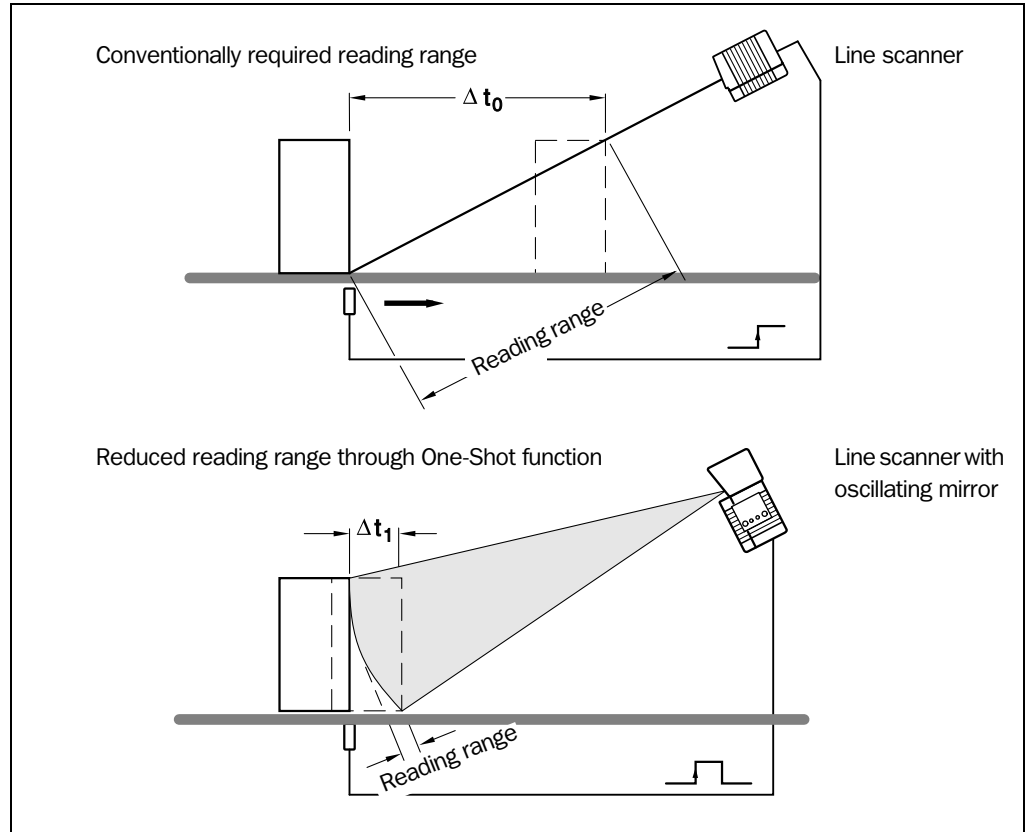

Fig. 6-6: One-Shot: Object tracking (bar code read from front)

f) Parameterizing reading mode

The selected reading mode depends on the number of objects that are simultaneously in the reading field of the CLV490 during each reading interval. This is independent of the number of bar codes on the actual object. [Table 6-10](#) shows an overview of the configurations and applications.

Configuration	Application	See Page
A. Stand-alone	Start/stop mode <ul style="list-style-type: none"> • One object in reading field per reading interval, reading one side 	6-21
	Tracking mode (controlled by increment) <ul style="list-style-type: none"> • Max. 10 objects in reading field per reading interval, reading one side, with internal object tracking 	6-27
B. Used in Omni Portal System (arrangement with OTS400 and other CLVs)	Start/stop modes <ul style="list-style-type: none"> • One object in reading field per reading interval, CLV490 involved in reading one side or more sides, master/slave arrangement with OTC400 controller 	6-30
	Tracking mode (controlled by increment) <ul style="list-style-type: none"> • Max. 20 objects in reading field per reading interval, CLV490 involved in reading one side or more sides, with object tracking by the OTC400 controller 	6-33

Table 6-10: Overview: CLV490 applications in stand-alone configuration or in arrangement with OTS400

A. CLV490 in stand-alone configuration

A1. Start/stopp mode

- **One object** in the reading field per reading interval, reading one side

Possible reading triggers:

- One external sensor (e. g. photoelectric reflex switch)
- Two external sensors
- Command strings
- Free-running mode
- Object polling (Autofocus mode "Minimum distance" or "Differential background")

Further preparations:

- Configuring reading area: see [Chapter a\) Parameterizing reading area, Page 6-10](#).
- Selecting focus control mode: see [Chapter b\) Selecting focus control mode, Page 6-11](#).
- Configuring focus control: see [Chapter c\) Parameterizing focus control, Page 6-12](#).
- Configuring oscillating mirror (optional): see [Chapter e\) Parameterizing oscillation mirror functions \(optional\), Page 6-17](#).
- Configuring no. of bar codes to be read: see [Chapter h\) Parameterizing the evaluation characteristics, Page 6-36](#).

Note The size of the reading field is determined by the distance between the start and stop sensors in conveying direction (see [Fig. 3-5, Page 3-9](#)). In object polling mode, the CLV490 detects automatically an object entering or leaving the reading field.

To separate bar codes of the same type with identical contents, connect an incremental encoder and activate the "Separate codes dependent on reading angle" function. See also [Chapter Separation of identical bar codes \(same code type/identical contents\), Page 6-36](#).

Parameterizing reading trigger in the CLV490:

Action	Settings in CLV-Setup
Parameterize reading trigger: one external sensor – or –	⇨ DEVICE CONFIGURATION tab Start: ⇨ READING TRIGGER SOURCE section – Sensor Input (Active High) <i>or</i> – Sensor Input (Active Low) ⇨ READING TRIGGER PARAMETERS button ⇨ DEBOUNCING SENSOR section – Standard <i>or</i> – Fast <i>or</i> – Time controlled: value <i>or</i> – Track controlled: value (with connected increment encoder) ⇨ FIRST TRIGGER SENSOR section – Edge <i>or</i> – Level Stop: ⇨ END OF READING INTERVAL section – generated by Trigger Source <i>or</i> – Timer: Timeout (referred to beginning of reading interval) Output of reading result referred to beginning of reading interval: ⇨ DEVICE CONFIGURATION tab ⇨ OUTPUT ON GOOD READ section – End of reading gate <i>or</i> – Immediate <i>or</i> – End of Label ⇨ Using End of label: READING TRIGGER PARAMETERS button ⇨ END OF LABEL/FREE-RUNNING section ⇨ Timeout Note: Connect the external sensor to "Sensor" switching input!

Table 6-11: Guide: Parameterizing the reading trigger for start/stopp mode in stand-alone configuration

Action	Settings in CLV-Setup
Parameterize reading trigger: two external sensors – or –	⇨ DEVICE CONFIGURATION tab Start (sensor 1): ⇨ READING TRIGGER SOURCE section – Sensor Input (Active High) <i>or</i> – Sensor Input (Active Low) ⇨ READING TRIGGER PARAMETERS button ⇨ DEBOUNCING SENSOR section (also for sensor 2 on IN 4) – Standard <i>or</i> – Fast <i>or</i> – Time controlled: value ⇨ FIRST TRIGGER SENSOR section – Edge <i>or</i> – Level Stop (sensor 2): ⇨ END OF READING INTERVAL section – generated by IN 4 ⇨ DEVICE CONFIGURATION tab ⇨ ASSIGNMENT OF INPUTS section ⇨ IN 4 – Reading Trigger Stop (Active High) <i>or</i> – Reading Trigger Stop (Active Low) Output of reading result referred to beginning of reading interval: ⇨ OUTPUT ON GOOD READ section – End of reading gate <i>or</i> – Immediate <i>or</i> – End of Label ⇨ Using End of label: READING TRIGGER PARAMETERS button ⇨ END OF LABEL/FREE-RUNNING section – Timeout Note: Connect external sensor 1 (start) to "Sensor" switching input and sensor 2 (stop) to "IN 4" switching input!

Table 6-11: Guide: Parameterizing the reading trigger for start/stopp mode in stand-alone configuration (contd.)

Action	Settings in CLV-Setup
Parameterize reading trigger: command strings – or –	⇨ DEVICE CONFIGURATION tab Start: ⇨ READING TRIGGER SOURCE section – Serial Interface Stop: ⇨ READING TRIGGER PARAMETERS button ⇨ END OF READING INTERVAL section – generated by Trigger Source <i>or</i> – Timer: Timeout (referred to beginning of reading interval) Trigger characters: ⇨ SERIAL INTERFACE section – Standard Trigger <i>or</i> – Single character ⇨ Using single character: start and stop characters ⇨ Echo on/off Output of reading result referred to beginning of reading interval: ⇨ DEVICE CONFIGURATION tab ⇨ OUTPUT ON GOOD READ section – End of reading gate <i>or</i> – Immediate <i>or</i> – End of Label ⇨ Using End of label: READING TRIGGER PARAMETERS button ⇨ END OF LABEL/FREE-RUNNING section ⇨ Timeout
Parameterize reading trigger: free-running – or –	⇨ DEVICE CONFIGURATION tab Start: ⇨ READING TRIGGER SOURCE section – Free-running with Timeout: Timeout Stop (generated by reading trigger source): ⇨ READING TRIGGER PARAMETERS button ⇨ END OF LABEL/FREE-RUNNING section ⇨ Timeout Output of reading result referred to beginning of reading interval: ⇨ DEVICE CONFIGURATION tab ⇨ OUTPUT ON GOOD READ section – End of reading gate <i>or</i> – Immediate Note: No laser timeout function (defined switching off of laser diode due to too long active reading gate) available in this trigger mode.

Table 6-11: Guide: Parameterizing the reading trigger for start/stopp mode in stand-alone configuration (contd.)

Action	Settings in CLV-Setup
<p>Parameterize reading trigger: Object polling</p>	<p>⇒ DEVICE CONFIGURATION tab</p> <p>Activating object polling:</p> <p>Start:</p> <p>⇒ READING TRIGGER SOURCE section</p> <ul style="list-style-type: none"> - Object polling <p>Stop:</p> <p>⇒ READING TRIGGER SOURCE section</p> <ul style="list-style-type: none"> ⇒ END OF READING INTERVAL section - generated by Trigger Source <i>or</i> - Timer: Timeout (referred to beginning of reading interval) <i>or</i> - generated by IN 4 <p>⇒ Using IN 4: DEVICE CONFIGURATION tab</p> <ul style="list-style-type: none"> ⇒ ASSIGNMENT OF INPUTS section ⇒ IN 4 - Reading Trigger Stop (Active High) <i>or</i> - Reading Trigger Stop (Active Low) <p>Configuring object polling:</p> <p>⇒ OBJECT POLLING PARAMETERS button</p> <ul style="list-style-type: none"> ⇒ POLLING PROPERTIES section - Search time - Pause time - Minimum object recognition - Minimum object width <p>⇒ OBJECT DETECT SPACE section</p> <ul style="list-style-type: none"> - Right edge of conveyor (Y 1) - Left edge of conveyor (Y 2) - Level of conveyor (Z 1) - Maximum scanning height (Z 2) <p>⇒ SCAN ANGLE LIMITATION section</p> <ul style="list-style-type: none"> - Min. and max. angle <p><i>Oscillating mirror:</i></p> <p>⇒ additionally: OSCILLATING ANGLE LIMITATION section</p> <ul style="list-style-type: none"> - Min. and max. value <p>Define scanner position referred to the conveyor belt:</p> <p>⇒ see Table 6-4, Page 6-11, reading space, scanner position</p> <p>Online diagnosis of configured object detection space:</p> <p>⇒ Menu CLV490</p> <ul style="list-style-type: none"> ⇒ Background analysis - Analysis: object detection <p>Output of reading result referred to beginning of reading interval:</p> <p>⇒ DEVICE CONFIGURATION tab</p> <ul style="list-style-type: none"> ⇒ OUTPUT ON GOOD READ section - End of reading gate <i>or</i> - Immediate <i>or</i> - End of Label <p>⇒ Using End of label: READING TRIGGER PARAMETERS button</p> <ul style="list-style-type: none"> ⇒ END OF LABEL/FREE-RUNNING section - Timeout <p>Note:</p> <p>No laser timeout function (defined switching off of laser diode due to too long active reading gate) available in this trigger mode.</p>

Table 6-11: Guide: Parameterizing the reading trigger for start/stopp mode in stand-alone configuration (contd.)

Explanation Object polling

The process of setting up this automatic reading pulse control (object detection space, scan angle, and oscillating angle limitation) is not the same as that for defining the focus control (reading space and autofocus area) and has to be performed separately. The object detection space should include the rectangular autofocus space.

Object polling begins once the system has been started. To prevent incorrect triggering, the system does not return to reading mode from a different operating function or terminate a diagnosis function until a 5 second delay has elapsed.

The CLV490 can carry out object polling in autofocus mode with the "Minimum distance" and "Differential background" modes. The periodic object distance measurement is also used for object detection in the parameterizable search interval. The autofocus, however, is only active during the reading gate. To ensure reliable object detection, the CLV490 must detect an object of the defined minimum width within a preset time in every distance profile (line scanner with oscillating mirror: in at least 3 distance profiles over at least 500 ms). This time is used to debounce the object detection prior to automatic starting of the internal reading gate. Only **one object** should be in the reading field at any one time.

Blanking: the smallest parameterizable object width required for an object to be detected and the reading gate to be started is 100 mm (3.94 in). The minimum object width when the object leaves the reading field (end of reading gate) is 50 mm (1.97 in) (fixed). The object width here is not dependent on the distance between the object distance and the CLV490. After an active reading gate, the pause interval must be at least 70 ms. If the parameterized pause interval is any shorter, the CLV490 searches for objects continuously with its laser diode permanently switched on. This reduces the service life of the laser diode. In this pulse mode, the oscillating mirror can oscillate permanently or only during the active reading gate.

A2. Tracking mode (controlled by Increment)

- Max. **10 consecutive objects** in conveyor direction simultaneously in the reading field, reading one side with internal object tracking

Conditions:

- Minimum object gap between two objects in conveyor direction: **50 mm (1.97 in)**
- Size of reading field = distance between sensor for beginning/end of object and object release point parameterized (data output)
- Autofocus mode "Differential background and tracking", see [Table 6-6, Page 6-13](#) or event-controlled focus position switchover
- Incremental encoder connected to "IN 4" switching input

Possible reading triggers:

- One external sensor (e. g. photoelectric reflex switch)
- Command strings

Further preparations:

- Configuring reading area: see [Chapter a\) Parameterizing reading area, Page 6-10](#).
- Selecting focus control mode: see [Chapter b\) Selecting focus control mode, Page 6-11](#).
- Configuring focus control: see [Chapter c\) Parameterizing focus control, Page 6-12](#).
- Configuring oscillating mirror (optional): see [Chapter e\) Parameterizing oscillation mirror functions \(optional\), Page 6-17](#).
- Configuring no. of bar codes to be read: see [Chapter h\) Parameterizing the evaluation characteristics, Page 6-36](#)

Note To separate bar codes of the same type with identical contents, connect an incremental encoder and activate the "Separate codes dependent on reading angle" function. See also [Table 6-24, Page 6-36](#).

Activating and parameterizing internal object tracking:

Action	Settings in CLV-Setup
1. Parameterize internal object tracking	⇨ DEVICE CONFIGURATION tab ⇨ INTERNAL TRACKING section – active ⇨ DISTANCE PER ENCODER PULSE section – Value: according to encoder resolution ⇨ TRACKING PARAMETERS button ⇨ RELEASE POINTS section – Focus release point – Object release point/End of reading field/Output data ⇨ LABEL ASSIGNMENT TOLERANCE section – Automatic (default setting) <i>or</i> – Fix Tolerance: value ⇨ READING CONFIGURATION tab ⇨ AUTOFOCUS PARAMETERS button ⇨ AUTOFOCUS PARAMETERS tab – CODE BASED FOCUS RELEASE IF... section – Number of codes equals Minimum <i>or</i> – Number of codes equals Maximum <i>or</i> – Number of codes exceeds Maximum

Table 6-12: Guide: Parameterizing internal object tracking

Action	Settings in CLV-Setup
1. Parameterize internal object tracking – <i>contd.</i> –	<ul style="list-style-type: none"> ⇒ DEVICE CONFIGURATION tab ⇒ ASSIGNMENT OF INPUTS section ⇒ IN 4 <ul style="list-style-type: none"> – Conveyor increment <p>Note: Connect external incremental encoder to "IN 4" switching input!</p>
2. Define scanner position referred to the reading field	<ul style="list-style-type: none"> ⇒ DEVICE CONFIGURATION tab ⇒ SCANNER POSITIONS PARAMETERS button ⇒ ANGLES section <ul style="list-style-type: none"> – Angles: alpha, beta and gamma ⇒ COORDINATES section <ul style="list-style-type: none"> – x-, y- and z-coordinates
3. Teach-in background (optional)	<ul style="list-style-type: none"> ⇒ Menu CLV490 ⇒ DEVICE FUNCTIONS <ul style="list-style-type: none"> ⇒ Background <ul style="list-style-type: none"> – Teach-in <p>Check taught-in background:</p> <ul style="list-style-type: none"> ⇒ READING CONFIGURATION tab ⇒ AUTOFOCUS section <ul style="list-style-type: none"> – SHOW BACKGROUND button <p>Display actual background profile:</p> <ul style="list-style-type: none"> ⇒ Menu CLV490 ⇒ BACKGROUND ANALYSIS

Table 6-12: Guide: Parameterizing internal object tracking (contd.)

Explanation Internal object tracking

Internal object tracking can be used in autofocus mode with "Differential background and tracking" mode or with event-controlled focus position switchover (e.g. by means of height-control photoelectric switches at switching inputs "IN 0" to "IN 3"). If the reading pulse is started via an external sensor, fast debouncing (≤ 5 ms) is used for the "Sensor" switching input irrespective of the parameter settings. The CLV490 receives the signals from the incremental encoder via switching input "IN 4". At a constant conveyor speed, the increment can be triggered via an internal timer increment (100 Hz) (set the value for "Path per increment encoder pulse" to 0), which means that an encoder does not need to be connected to IN 4.

With object tracking, the reading field length corresponds to the distance in conveying direction between the sensor for starting the reading pulse and the parameterized object release point (see [Fig. 3-5, Page 3-9](#)). The focus release point is before the object release point. The CLV490 uses the internal object management system and its object list to track the objects passing through the reading field, whereby the object instance measurement enables objects to be detected and the corresponding focus positions in the focus list to be assigned. The increment management system continuously locates the current position of the objects in the reading field in the conveying direction. The focus list acts as a circular buffer, whereby the oldest entry determines the current focus position. If the CLV490 calculates that the end of an object being conveyed through the reading field has passed the parameterized focus release point, the CLV490 switches to the next focus position and deletes the object from the focus list. The reading result for an object is not output until the object has left the object release point.

Parameterizing reading trigger in the CLV490:

Action	Settings in CLV-Setup
Parameterize reading trigger: one external sensor	⇨ DEVICE CONFIGURATION tab Start: ⇨ READING TRIGGER SOURCE section – Sensor Input (Active High) <i>or</i> – Sensor Input (Active Low) ⇨ READING TRIGGER PARAMETERS button ⇨ DEBOUNCING SENSOR section – Fast ⇨ FIRST TRIGGER SENSOR section – Edge <i>or</i> – Level Stop: generated by object release point Output of reading result referred to beginning of reading interval: ⇨ DEVICE CONFIGURATION tab ⇨ TRACKING PARAMETERS button ⇨ RELEASE POINTS section – Object release point/End of reading field/Output data Note: Connect the external sensor to "Sensor" switching input!
Parameterize reading trigger: command strings	⇨ DEVICE CONFIGURATION tab Start: ⇨ READING TRIGGER SOURCE section – Serial interface Stop: generated by object release point Output of reading result referred to beginning of reading interval: ⇨ DEVICE CONFIGURATION tab ⇨ TRACKING PARAMETERS button ⇨ RELEASE POINTS section – Object release point/End of reading field/Output data Trigger characters: ⇨ SERIAL INTERFACE section – Standard Trigger <i>or</i> – Single character ⇨ Using single character: start and stop characters ⇨ Echo on/off

Table 6-13: Guide: Parameterizing the reading mode for tracking mode in stand-alone configuration

B. CLV490 integrated in OTS400 Omni Tracking System (mechanical construction called "reading gate")

B1. Start/stop mode

Conditions:

- **One object** in the reading field per reading interval
Example: Omni-directional 2-side reading with CLVs (slaves) und OTC400 Controller (master)
- Minimum object distance > size of reading field
(size of reading field = distance between sensor for start and stop of reading trigger)
- Autofocus/focus position switchover in the CLV490 according to application:
 - with OTS height information via CAN bus for reading from top
 - one distance configuration (fixed focus) for e. g. reading from side and sufficient depth of field (DOF)
- Autofocus mode "Minimum distance" or "Differential background",
see [Table 6-6, Page 6-13](#)
- Two reading sensors connected to OTC400 (start and stop)
- Height detection photo reflex switches connected to OTC400 (optional)
- Master/slave arrangement using the CAN interface

Possible reading triggers in the CLV490:

- OTS trigger

Further preparations for each CLV490:

- Configuring reading area: see [Chapter a\) Parameterizing reading area, Page 6-10](#).
- Selecting focus control mode: see [Chapter b\) Selecting focus control mode, Page 6-11](#).
- Configuring focus control: see [Chapter c\) Parameterizing focus control, Page 6-12](#).
- Configuring oscillating mirror (optional): see [Chapter e\) Parameterizing oscillation mirror functions \(optional\), Page 6-17](#).
- Configuring no. of bar codes to be read: see [Chapter h\) Parameterizing the evaluation characteristics, Page 6-36](#).

Note To separate bar codes of the same type with identical contents, connect an incremental encoder and activate the "Separate codes dependent on reading angle" function. See also [Table 6-24, Page 6-36](#).

Parameterizing focus control in the CLV490:

Action	Settings in CLV-Setup
Use distance information of OTC400 (master) or other CLV – or –	⇒ READING CONFIGURATION tab ⇒ FOCUS CONTROL section – OTS height information
Select and parameterize autofocus function or –	see Table 6-6, Page 6-13

Table 6-14: Guide: Parameterizing focus control in CLV490 for master/slaves arrangement with OTC400

Action	Settings in CLV-Setup
Select fixed focus and parameterize one distance configuration	see Table 6-8, Page 6-16
Forwarding distance informations (optional)	<ul style="list-style-type: none"> ⇒ READING CONFIGURATION tab ⇒ FOCUS CONTROL section <ul style="list-style-type: none"> ⇒ AUTOFOCUS PARAMETERS button <ul style="list-style-type: none"> – AUTOFOCUS OPTIMIZATION PARAMETERS button – OBJECT HEIGHT PASSING IN OTS MODE section – Active

Table 6-14: Guide: Parameterizing focus control in CLV490 for master/slaves arrangement with OTC400

Parameterizing reading trigger in the CLV490:

Action	Settings in CLV-Setup
Parameterize reading trigger	<ul style="list-style-type: none"> ⇒ DEVICE CONFIGURATION tab <ul style="list-style-type: none"> ⇒ READING TRIGGER SOURCE section <ul style="list-style-type: none"> – OTS trigger

Table 6-15: Guide: Parameterizing reading trigger in the CLV490 for master/slave arrangement with OTC400

Parameterizing slave mode in the CLV490:

Action	Settings in CLV-Setup
1. Enable slave mode in CLV490 for OTC400 (master)	<ul style="list-style-type: none"> ⇒ DEVICE CONFIGURATION tab ⇒ TRACKING PARAMETERS button <ul style="list-style-type: none"> ⇒ RELEASE POINTS section <ul style="list-style-type: none"> – Object release point/End of reading field/Output data: 0 mm! – Control box "Master/slave via OTC" active
2. Forwarding reading results to the CAN interface	<ul style="list-style-type: none"> ⇒ HOST INTERFACE tab <ul style="list-style-type: none"> ⇒ DESTINATION OF RESULT DATA STRINGS section <ul style="list-style-type: none"> – CAN interface
3. Parameterize CAN interface	<ul style="list-style-type: none"> ⇒ CAN INTERFACE tab <ul style="list-style-type: none"> ⇒ CAN INTERFACE FUNCTION section <ul style="list-style-type: none"> – OTS slave ⇒ CAN DATA RATE section <ul style="list-style-type: none"> – 500 kBit/s

Table 6-16: Guide: Parameterizing slave mode in the CLV490 for arrangement with OTC400 (master)

Note When in slave mode, the CLV490 receives the trigger signals for the reading pulse (start and stop) from the OTC400 via the CAN bus along with (depending on the parameter settings) the distance information required for focus position switchover/autofocus. The distance information can be generated, for example, by the OTC400 by means of height-control photoelectric switches or can originate from another CLV490, which forwards its distance measurements.

The CLV490 sends the reading result (bar code contents) to the OTC400 via the bus as soon as the bar code(s) have been successfully read. The OTC400 compiles the results received from all the slaves and evaluates them accordingly before sending them to the host.

OTC400 Controller:

Beside other functions parameterize the following function in the OTC400:

Action	Settings in CLV-Setup
Parameterize operation mode in the OTC400 (master)	⇒ DEVICE CONFIGURATION tab ⇒ READING TRIGGER PARAMETERS button ⇒ OPERATING MODE section – Time controlled (master/slave) output at end of reading gate or – Time controlled (master/slave) output immediate if...

Table 6-17: Guide: Parameterizing operation mode in the OTC400 for master/slaves arrangement



For further function to be parameterized in the OTC400 see the "*OTS400 Omni Tracking System*" Operating instructions (order no. 8008869, English edition).

B2. Tracking mode (controlled by increment)

Note SICK AG can design and preconfigure more complex omni-portal systems to fulfill the customer's reading requirements and then provide appropriately trained personnel to install, test and put these systems into operation.

An overview of the parameterization steps for an example situation is given below (the overview does not include all available parameterization options).

Conditions:

- **Max. 20 consecutive objects** in conveyor direction simultaneously in the reading field.
Example: Omni-directional 3-side reading with groups of CLV490 (slaves) and OTC400 Controller (master) for object tracking
- Minimum object gap between two objects in conveyor direction: **50 mm (1.97 in)**
- Size of reading field = distance between sensor for beginning/end of object and object release point parameterized in the OTC400 (data output)
- Autofocus/focus position switchover in the CLV490 according to application:
 - with OTS height information via CAN bus for reading from top
 - one distance configuration (fixed focus) for e. g. reading from side and sufficient depth of field (DOF)
- Autofocus mode "Differential background and tracking", see [Table 6-6, Page 6-13](#)
- Sensor for beginning/end of object and incremental encoder connected to the OTC400
- Master/slave arrangement using the CAN interface

Possible reading triggers:

- via OTS

Further preparations for each CLV490:

- Configuring reading area: see [Chapter a\) Parameterizing reading area, Page 6-10](#).
- Selecting focus control mode: see [Chapter b\) Selecting focus control mode, Page 6-11](#).
- Configuring focus control: see [Chapter c\) Parameterizing focus control, Page 6-12](#).
- Configuring oscillating mirror (optional): see [Chapter e\) Parameterizing oscillation mirror functions \(optional\), Page 6-17](#).
- Configuring no. of bar codes to be read: see [Chapter h\) Parameterizing the evaluation characteristics, Page 6-36](#)

Note To separate bar codes of the same type with identical contents, connect an incremental encoder and activate the "Separate codes dependent on reading angle" function. See also [Table 6-24, Page 6-36](#).

Parameterizing focus control in the CLV490:

Action	Settings in CLV-Setup
Use distance information of OTC400 (master) or other CLV490 – or –	⇒ READING CONFIGURATION tab ⇒ FOCUS CONTROL section – OTS height information
Select and parameterize autofocus function – or –	see Table 6-6, Page 6-13

Table 6-18: Guide: Parameterizing focus control in CLV490 for object tracking mode with OTC400

Action	Settings in CLV-Setup
Select fixed focus and parameterize one distance configuration	see Table 6-8, Page 6-16
Forwarding distance informations (optional)	<ul style="list-style-type: none"> ⇒ READING CONFIGURATION tab ⇒ FOCUS CONTROL section <ul style="list-style-type: none"> ⇒ AUTOFOCUS PARAMETERS button <ul style="list-style-type: none"> – AUTOFOCUS OPTIMIZATION PARAMETERS button – OBJECT HEIGHT PASSING IN OTS MODE section – Active

Table 6-18: Guide: Parameterizing focus control in CLV490 for object tracking mode with OTC400

Parameterizing reading trigger in the CLV490:

Action	Settings in CLV-Setup
Parameterize reading trigger	<ul style="list-style-type: none"> ⇒ DEVICE CONFIGURATION tab <ul style="list-style-type: none"> ⇒ READING TRIGGER SOURCE section <ul style="list-style-type: none"> – OTS trigger

Table 6-19: Guide: Parameterizing reading trigger in the CLV490 for object tracking mode with OTC400

Parameterizing tracking in the CLV490:

Action	Settings in CLV-Setup
1. Define scanner position referred to conveyor belt	<ul style="list-style-type: none"> ⇒ DEVICE CONFIGURATION tab ⇒ SCANNER POSITIONS PARAMETERS button <ul style="list-style-type: none"> ⇒ ANGLES section <ul style="list-style-type: none"> – Angles: alpha, beta and gamma ⇒ COORDINATES section <ul style="list-style-type: none"> – x-, y- and z-coordinates
2. Parameterize scale factor for incremental pulse	<ul style="list-style-type: none"> ⇒ DEVICE CONFIGURATION tab <ul style="list-style-type: none"> ⇒ DISTANCE PER ENCODER PULSE section <ul style="list-style-type: none"> – Value (in agreement with incremental encoder and OTC400)
3. Define release points	<ul style="list-style-type: none"> ⇒ DEVICE CONFIGURATION tab ⇒ TRACKING PARAMETERS button <ul style="list-style-type: none"> ⇒ RELEASE POINTS section <ul style="list-style-type: none"> – Focus release point: value – Object release point/End of reading field/Output data: value
4. Define label assignment tolerance for object gaps	<ul style="list-style-type: none"> ⇒ DEVICE CONFIGURATION tab ⇒ TRACKING PARAMETERS button <ul style="list-style-type: none"> ⇒ LABEL ASSIGNMENT TOLERANCE section <ul style="list-style-type: none"> – Automatic <i>or</i> – Fixed Tolerance: value

Table 6-20: Guide: Parameterizing tracking in the CLV490 for object tracking mode with OTC400

Explanation Object tracking takes place in every CLV490 in the system. For this purpose, each CLV490 continuously compiles an internal object list. When in slave mode, the CLV490 receives the required tracking information for the objects in the reading field from the OTC400 via the CAN bus.

As soon as a successful reading has been made, the CLV490 sends the reading result to the OTC400 via the CAN bus. The OTC400 then compiles the results with the same name

(identical bar-code contents) received from all the slaves and sends this filtered overall reading result for each object to the host at a defined output time during the reading process. The object release point (data output) parameterized in the OTC400 marks the end of the reading field. The object release point parameterized in the CLV490 must always be smaller than that of the OTC400. The parameter setting for the focus release point depends on whether the CLV490 is used as part of a group and on its position relative to the conveyor belt. The focus release point is the point in the reading field at which the CLV490 permits a new focus switchover when the tracked object has passed this point, even if the number of bar codes to be read has not yet been reached.

Parameterizing slave mode in the CLV490:

Action	Settings in CLV-Setup
Parameterize CAN interface	⇒ CAN INTERFACE tab ⇒ CAN INTERFACE FUNCTION section – OTS slave ⇒ CAN DATA RATE section – 500 kBit/s

Table 6-21: Guide: Parameterizing slave mode in the CLV490 for object tracking mode with OTC400

OTC400 Controller:

Beside other functions parameterize the following function in the OTC400:

Action	Settings in CLV-Setup
Parameterize operation mode in the OTC400 (master)	⇒ DEVICE CONFIGURATION tab ⇒ READING TRIGGER PARAMETERS button ⇒ OPERATING MODE section – Increment controlled (Tracking)

Table 6-22: Guide: Parameterizing tracking mode in the OTC400



For further function to be parameterized in the OTC400 see the "*OTS400 Omni Tracking System*" Operating instructions (order no. 8008869, English edition).

g) Parameterizing laser timeout (for trigger source "Sensor input"/"Ser. interface")

Action	Settings
1. Choose laser timeout duration – or –	⇒ DEVICE CONFIGURATION tab ⇒ READING TRIGGER PARAMETERS button ⇒ LASER TIMEOUT section – Duration
2. Deactivate laser timeout (The laser diode is always active, independent of the pulse duration)	⇒ LASER TIMEOUT section – Click (deactivate) the control box INTERVAL ACTIVE

Table 6-23: Guide: Parameterizing the laser timeout

h) Parameterizing the evaluation characteristics

- Choose decoder type ⇒ CODE CONFIGURATION tab ⇒ DECODER section
- Activate code types for evaluation ⇒ CODE CONFIGURATION tab ⇒ SYMBOLOGIES section and EDIT button
- Activate code comparison ⇒ DEVICE CONFIGURATION tab ⇒ MATCH CODE PARAMETERS button

Separation of identical bar codes (same code type/identical contents)

Number of bar codes per object	Stationary conveyor object	Moving conveyor object
Number n > 1: – Same code type – Contents different or identical	⇒ CODE CONFIGURATION tab ⇒ CODE POSITION section – Activate "Seperate codes dependent on reading angle" – Min. distance between labels ⇒ NUMBER OF CODES section – Minimum – Maximum	⇒ CODE CONFIGURATION tab ⇒ CODE POSITION section – Activate "Seperate codes dependent on reading angle" – Min. distance between labels ⇒ NUMBER OF CODES section – Minimum – Maximum ⇒ DEVICE CONFIGURATION tab ⇒ SCANNER POSITION PARAMETERS button ⇒ ANGLES section – Angle alpha ⇒ DISTANCE PER ENCODER PULSE section – value

Table 6-24: Guide: Parameterizing the separation of identical bar codes

Note If the number $n > 1$, minimum distances must be provided between the bar codes on the object, if

- the SMART decoder is to read bar codes that originate from the same code type and have identical or different data contents
- the standard decoder is to read and distinguish bar codes with the same name (identical code type and data content)

The necessary calculations are provided in [Chapter 10.8.3 Calculating the necessary capture area for the bar code if several bar codes are read on each object, Page 10-58.](#)

i) Parameterizing the output characteristics

Result status: swichting outputs/ "Read Result" LED:

- Define function of result status output of "Result 1" to "Result 4" switching outputs ("Read Result" LED): DEVICE CONFIGURATION tab ⇒ RESULT OUTPUT PARAMETERS button

Main Data Interface general:

- Destination result data strings ⇒ HOST INTERFACE tab ⇒ DESTINATION OF RESULT DATA STRINGS section
- Filter reading result ⇒ DEVICE CONFIGURATION tab ⇒ ODETTE FILTER section
- Sort reading result ⇒ DATA STRINGS tab ⇒ OUTPUT SEQUENCE SORT section
- Mask reading result ⇒ DATA STRINGS tab ⇒ FORMAT MASK section

Host Interface:

- Arrangement in data network ⇒ DEVICE CONFIGURATION tab ⇒ SCANNER ARRANGEMENT section
- Physical interface ⇒ HOST INTERFACE tab ⇒ DATA FORMAT section
- Communication parameters ⇒ HOST INTERFACE tab ⇒ DATA FORMAT section
- Protocol ⇒ HOST INTERFACE tab ⇒ INTERFACE PROTOCOL section

Function of the CAN interface (alternative):



See the operating instructions "*Application of the CAN interface*" (no. 8009180, English edition)

Data output string of host interface:

- Choose contents of "Header", "Code Info/Separator", "Splitter" and "Terminator" blocks ⇒ DATA STRINGS tab ⇒ OUTPUT FORMAT section
- Position of "Code Info/Separator" blocks in data output string ⇒ DATA STRINGS tab ⇒ POSITION OF CODE INFO/SEPARATOR section
- Set wrong read format ⇒ DATA STRINGS tab ⇒ READING DATA IN CASE OF ERROR section, CHARACTER COUNT section and ERROR STRING section
- If necessary, parameterize/activate test string ⇒ DATA STRINGS tab ⇒ TEST STRING section
- Parameterize special functions ⇒ DATA STRINGS tab ⇒ SPECIALS button
- Output external data string as reading result ⇒ DATA STRINGS tab ⇒ EXTERNAL DATA STRING PARAMETERS button

j) Parameterizing the auxiliary interface mode (auxiliary interface)

- AUXILIARY INTERFACE tab

k) Defining the start option for accessing the parameter set

- DEVICE CONFIGURATION tab ⇒ START WITH ... section

6.5 Operating modes and outputting the reading result

The following CLV490 operating modes/functions (and more) can be selected in CLV-Setup:

Standard operating mode:

- Reading mode

For setup:

- Percentage evaluation
- Adjusting mode

For adapting the device to the application at hand:

- Configuring (parameterizing) the CLV490.
See [Chapter 6.4.1 Configuring the CLV490 via the user interface of CLV-Setup, Page 6-5](#)
- Background teach-in
- Show background
- Show RA-limits

For monitoring purposes/trouble shooting:

- Background analysis
- I/O monitor in incremental pulse
- Display and edit operating data
- Reading diagnosis
- Monitor host interface
- Auxiliary input
- Self-test

6.5.1 Reading mode (standard operating mode)

The CLV490 performs a self-test after it has been switched on. It switches to Reading mode ("Device Ready" LED lights up). In the default setting the "Sensor" switching input is the (external) trigger source of the reading pulse. The reading result is output by the CLV490 at the end of the reading pulse via the host interface (default setting) and auxiliary interface.

Depending of the configuration, the "Result 1" to "Result 4" switching outputs become live for the predefined pulse length when defined events occur during the reading process (e. g. Good Read).

The reading result of the **auxiliary interface** can be displayed in the CLV-Setup Terminal Emulator. The CLV490 auxiliary interface must be set to the Reading Diagnosis mode for this purpose. This mode is selected for the default setting. The reading result of the auxiliary interface has a fixed, invariable format.

The Reading mode can be called up by choosing VIEW in the menu bar or via the Terminal Emulator.

Line scanner with oscillating mirror:

In the Reading mode the CLV490 deflects (by default) the scan line about the position $CW = 50$ at a frequency of 1 Hz and a maximum angle of $\pm 20^\circ$. 50 CW corresponds to an angle of deflection of 105° .



Displaying the reading result in the Terminal Emulator:

1. Click  in the toolbar.
The Terminal Emulator window is then displayed.
2. In the DEVICE MODE section, choose READING MODE.
3. Present the bar code pattern from [Fig. 6-1, Page 6-4](#) to the CLV490 and activate the reading pulse.
The scan line must not hit any object in a distance closer to the CLV490 than the represented bar code (default setting: autofocus mode "Minimum distance").
The "Sensor" LED lights up and the red scan line appears.
4. Ending the reading pulse.
The CLV490 displays the reading result in the output window of the Terminal Emulator.
The "Read Result" LED lights up for a duration of 100 ms (default setting).

[Fig. 6-7](#) shows two examples of the output of a reading result: "Good Read" and "No Read". The reading result comprises the data contents of the bar code(s) and the reading diagnosis data. [Fig. 6-8](#) explains the structure and function of the reading diagnosis data for "Good Read", and [Fig. 6-9](#) for "No Read".

Note The CLV490 only outputs several bar codes in the reading result of the **host interface** if the parameterized minimum and maximum number of bar codes is > 1 , and several bar codes have been presented to it. The number of bar codes to be read/output for each reading interval can be selected in the CODE CONFIGURATION tab in the NUMBER OF CODES section. The reading result of the **host interface** can also be displayed. [Chapter 6.5.10 Monitor Host Interface, Page 6-54](#) describes the procedure for this and the structure of the reading result in the default setting.

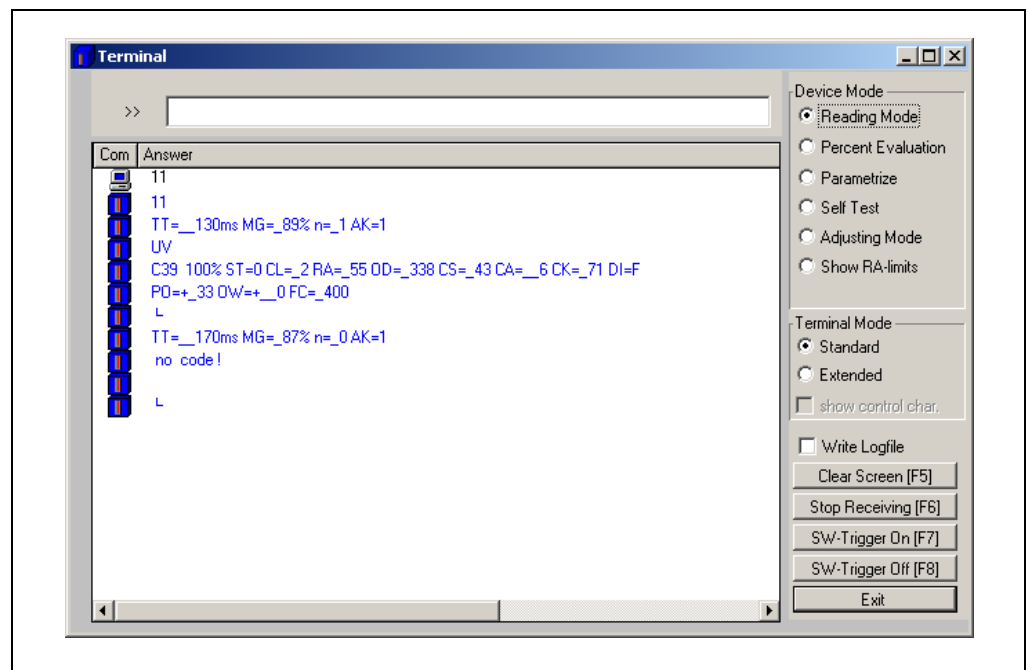

Fig. 6-7: CLV-Setup: Displaying the reading result of the terminal interface in the Terminal Emulator

Good Read:

TT=_130 ms MG=_89 % n=_1 AK=1
 UV
 C39 100% ST=0 CL=_2 RA=_55 OD=_338 CS=_43 CA=_6 CK=_71 DI=F
 PO=_33 OW=+_0 FC=_400

With:

1st. line :	TT	=	Duration of the reading interval (ms)
	MG	=	Temporal mean value of the identification quality (%)
	n	=	Number of detected bar codes
	AK	=	No. of the used distance configuration ¹⁾
2nd. line:	UV	=	Data contents of the bar code
3rd. line:	C39	=	ID: Code type Code 39 along
	100%	=	Identification quality (%)
	ST	=	Read status (ST = 0: Good Read)
	CL	=	Code length (number of characters)
	RA	=	Reading angle
	OD	=	Object distance, radial measured (mm)
	CS	=	Code reliability
	CA	=	Scan effort
	CK	=	Code continuity
	DI	=	Decoding direction (F = in scanning direction, R = against scanning direction)
4th line	PO	=	Exact reading angle (3-digit, in °)(unit 0,1°)
	OW	=	Exact oscillating angle (3-digit, in °)(unit 0,1°)
	FC	=	Current focus position (4-digit)
	ON	=	Consecutive object number

1) not relevant for autofocus function

Fig. 6-8: Reading result of the auxiliary interface: structure for "Good Read"

No Read:

TT=_170 ms MG=_87 % n=_0 AK=1
 no code!

1st. line :	TT	=	Duration of the reading interval (ms)
	MG	=	Temporal mean value of the identification quality (%)
	n	=	Number of codes detected
	AK	=	No. of the distance configuration used ¹⁾
2nd. line:	no code!	=	No bar codes found!

1) not relevant for autofocus function

Fig. 6-9: Reading result of the auxiliary interface: structure for "No Read"



Triggering the reading pulse via the Terminal Emulator

In the default setting the "Sensor" switching input is the (external) trigger source of the reading pulse. The reading pulse can also be triggered directly via the Terminal Emulator of CLV-Setup for test purposes. To do so, a different trigger source must be selected temporarily in the CLV490.

1. Choose DEVICE CONFIGURATION tab.
2. In the READING TRIGGER MODE section click the SERIAL INTERFACE option.
3. Perform a download to the CLV490.
To do so, click the SERIAL INTERFACE option again with the right mouse button and choose DOWNLOAD PARAMETER in the context menu.
CLV-Setup copies the parameter to the CLV490 temporarily.
The serial interface has been activated as the trigger source of the reading pulse and is ready to receive appropriate commands (until the CLV490 is switched off).
4. Click  in the toolbar.
The Terminal Emulator window is then displayed.
The CLV490 is in the Reading mode.
5. Click the SW-TRIGGER ON button or press [F7].
CLV-Setup sends a start command to the CLV490.
The "Sensor" LED lights up and the red scan line appears.
6. Present the bar code pattern from [Fig. 6-1, Page 6-4](#) to the CLV490.
7. Click the SW-TRIGGER OFF button or press [F8].
CLV-Setup sends a stop command to the CLV490. The "Sensor" LED is extinguished.
The CLV490 switches off the laser diode. The CLV490 displays the reading result in the output window of the Terminal Emulator. The "Read Result" LED lights up for a duration of 100 ms (default setting).

6.5.2 Percentage evaluation



In the Percentage evaluation mode, the quality of the reading function is assessed (no conveyor movement).

The CLV490 performs continuously 100 scans in the free running mode and evaluates the reading quality. It outputs the reading result every 2 s via the **auxiliary interface**. The reading results can be displayed in the Terminal Emulator of CLV-Setup. The "Result 1" to "Result 4" switching outputs do not become live in the Percentage evaluation mode.

The **standard decoder** has to be set temporarily for the percentage evaluation.

The Percentage evaluation mode can be called up by choosing VIEW in the menu bar, as a device function via CLV490 (interactively), or via the Terminal Emulator.

Note *Autofocus mode:*

If the CLV490 operates with autofocus in stand-alone configuration, the Percentage evaluation mode can only be started in the Autofocus mode "Minimum distance" or "Differential background". The CLV490 fixes the timeout of the automatic focus position switchover to 30 ms, the preferred focus position is set to the last recognised object. If the CLV490 operates with autofocus in OTS mode ("Differential background and tracking"), the CLV490 switches automatically to the autofocus mode "Differential background" during the the Percentage evaluation mode.

Line scanner with oscillating mirror:

In the Percent Evaluation mode, the CLV490 behaves in the following manner:

- in "Oscillating" mode (basic setting: oscillating with a fixed amplitude), the CLV490 shuts off oscillation and positions the scan line under the angle $CW = 50$ (corresponds to a deflection angle below 105°). This position cannot be altered.
- in "One-Shot" mode, the CLV490 positions the scan line under the angle $CW = 50$ as well.
- in "Fixed position" mode, however the scan line's selected position remains unchanged.

1. Choose the CODE CONFIGURATION tab.

2. In the DECODER section, choose STANDARD.

3. Perform a download to the CLV490.

To do so, click the STANDARD option again with the right mouse button and choose DOWNLOAD PARAMETER in the context menu.

CLV-Setup copies the parameter to the CLV490 temporarily.

The CLV490 then operates with the standard decoder (until the CLV490 is switched off).

4. Click  in the toolbar.

The Terminal Emulator window is displayed. The CLV490 is in the Reading mode.

5. In the DEVICE MODE section, choose PERCENTAGE EVALUATION

The dialog box for choosing the distance configuration is then displayed.

6. Choose the appropriate distance configuration for the reading distance:

- with autofocus mode the distance configuration no. 1
- with event-controlled focus control the distance configuration that corresponds to the reading distance of the object (default setting: no. 1, focus position $F1 = 1,200$ mm (47.3 in)).

7. Confirm the dialog box with OK.

The "Device Ready" LED is extinguished. The CLV490 initiates the percentage evaluation and outputs the reading results continuously. An example shows [Fig. 6-10](#).

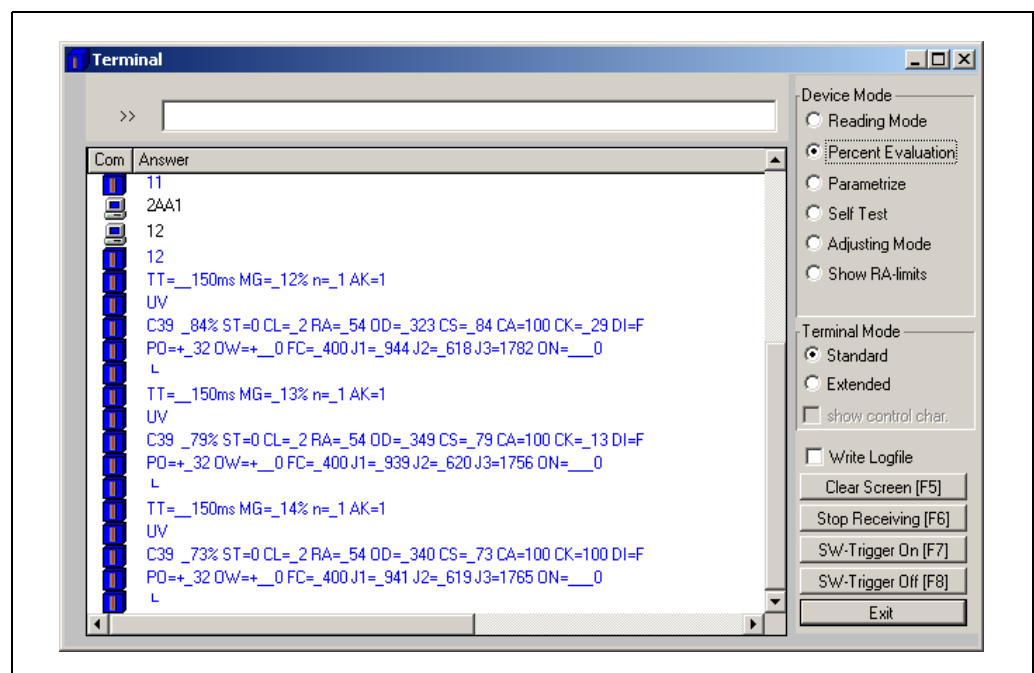

Fig. 6-10: CLV-Setup: Displaying the percentage evaluation in the Terminal Emulator

8. Present the bar code pattern from [Fig. 6-1, Page 6-4](#) and monitor the reading results in the Terminal Emulator window.

Note In default setting, the CLV490 operates in the autofocus mode "Minimum distance". As a result, the CLV490 focuses on the object that is nearest in Percentage Evaluation mode. The view on the object with the scan line must be unobstructed, i. e. any other objects must not protrude into the autofocus space. If they do so, the autofocus mode "Differential background" must be selected. Alternatively a fixed focus position can be set. See [Chapter c\) Parameterizing focus control, Page 6-12](#).

The output format of the reading result is the same as that of the Reading mode. [Fig. 6-8, Page 6-40](#) explains the structure and function of the reading diagnosis data

The "Read Result" LED also provides information on the reading quality:

- The LED is extinguished if reading quality is < 30 %
- The LED blinks twice per second if the reading quality is 30 % to 70 %
- The LED blinks five times per second if the reading quality is 70 % to 90 %
- The LED is lit continuously if the reading quality is > 90 %

6.5.3 Adjusting mode



The Adjusting mode enables the center of the scan line to be optimally positioned on the bar code. [Chapter 4.3.3 Adjusting mode, Page 4-10](#) describes the procedure for going about this after the Adjusting mode has been called up. The CLV490 does not output a reading result in this mode. The "Result 1" to "Result 4" switching outputs do not become live.

The Adjusting mode can be called up by choosing VIEW in the menu bar, as a device function via CLV490 (interactively), or via the Terminal Emulator.

Line scanner with oscillating mirror:

In the "Adjusting" mode, the CLV490 behaves in the following manner:

- In "Oscillating" mode (default setting: oscillating with a fixed amplitude), the CLV490 shuts off oscillation and positions the scan line under the angle $CW = 50$ (corresponds to an angle of deflection below 105°). This position cannot be altered.
- In "One-Shot" mode, the CLV490 positions the scan line under the angle $CW = 50$
- In "Fixed Position" mode, the scan line's selected position remains unchanged.

1. Click  in the toolbar.
The Terminal Emulator window is then displayed. The CLV490 is in the Reading mode.
2. In the DEVICE MODE section, choose ADJUSTING MODE.
The "Device Ready" LED is extinguished. The CLV490 cancels the Reading mode and blanks the red scan line as of reading angle $RA = 50$ to reading angle $RA = 100$.
3. Choose READING MODE to exit the Adjusting mode.
The CLV490 returns to the Reading mode and the "Device Ready" LED lights up.

6.5.4 Background teach-in

If the Autofocus function is used in the "Differential Background" or "Differential Background and Tracking" mode, the CLV490 must first learn the **ambient background** in its reading field to narrow the reading field even further. When the internal distance profile is set, the reading field of the CLV490 must **not contain any objects**. In this mode, the CLV490 does not output any reading results.

The Background teach-in function can be started as a device function via CLV490 (interactively), or press the [F2] key.

Line scanner with oscillating mirror:

In the "Background teach-in" mode, the CLV490 behaves in the following manner:

- in "Oscillating" mode (default setting: oscillating with a fixed amplitude), the CLV490 shuts off oscillation and positions the scan line under the angle $CW = 50$ (corresponds to an angle of deflection below 105°). This position cannot be altered.
- in "One-Shot" mode, the CLV490 positions the scan line under the angle $CW = 50$.
- in "Fixed Position" mode, the scan line's selected position remains unchanged.



Starting the background teach-in:

1. Mount the CLV490 at the reading station and align it with an object containing a bar code.
2. Remove the object so that the CLV490 has an unobstructed view of the background.
3. Choose CLV490, DEVICE FUNCTIONS, BACKGROUND, TEACH-IN

– or –

press the [F2] key.

The EXECUTE DEVICE FUNCTIONS window opens.

Choose BACKGROUND, TEACH-IN in the EXECUTE menu.

The "Device Ready" LED extinguishes. The CLV490 then scans its background and learns the ambient background so that it can create a suitable distance profile.

The CLV490 outputs a message once the teach-in procedure has been successfully completed (see [Fig 6-11](#)).

The CLV490 has then learned the ambient background.



Fig. 6-11: CLV-Setup: Dialog window for running the background teach-in

4. Choose CLOSE to close the window.
If the parameters in the CLV490 were modified as a result of the teach-in procedure, CLV-Setup asks you whether you want to copy and display the modified parameter set by uploading it from the CLV490.
5. Confirm the query with YES.
The dialog box closes automatically.
The CLV490 resumes Reading mode and the "Device Ready" LED lights up.

Displaying the taught-in background:

The new background distance profile can be uploaded and displayed in CLV-Setup via the auxiliary interface of the CLV490. CLV-Setup displays the background without any parameterized limitations ("Autofocus space").

1. Choose the READING CONFIGURATION tab.
2. In the AUTOFOCUS section, click the SHOW BACKGROUND button.
The SHOW BACKGROUND dialog box appears.
An example of a distance profile is shown in [Fig. 6-12](#).

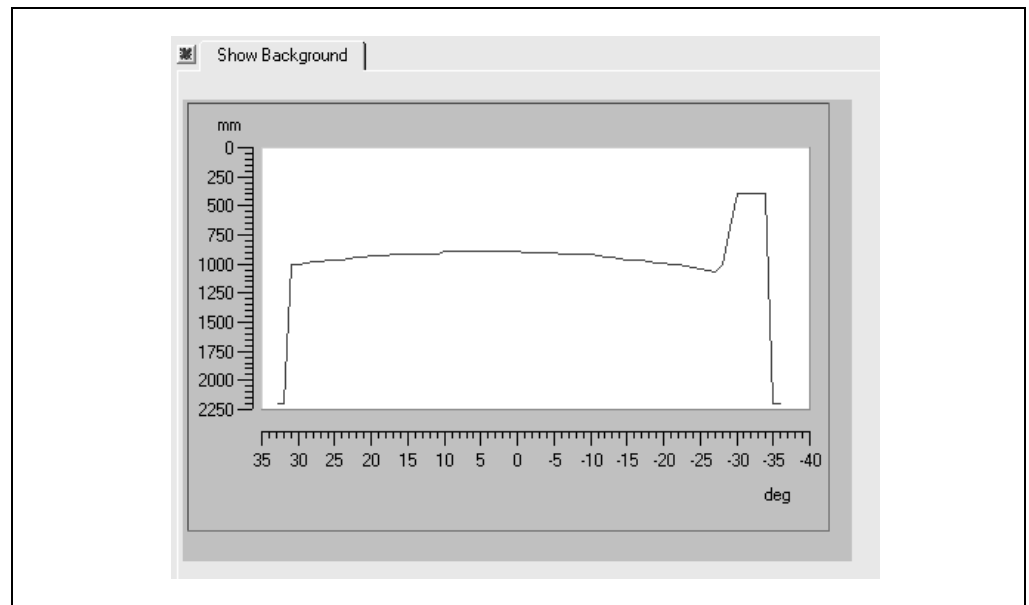

Fig. 6-12: CLV-Setup: Display of the learned background

Note The CLV490 adjusts the entire profile of the taught-in background by minus 100 mm (3.94 in), that is, the entire background curve is moved toward the CLV490 by this amount (also in the display in CLV-Setup) to compensate measurement inaccuracies. The parameterized limits of the applicable autofocus space are not corrected. The CLV490 also shifts the edges of the measured profile toward the center by 2 angular elements. If no background has been taught in, the CLV490 uses the default background (2,200 mm (86.7 in) across the entire distance profile).

6.5.5 Show RA-limits

In this mode, the CLV490 blanks certain parts of the red scan line so that any limit values defined for the active evaluation range of the scan line can be checked directly during parameterization. The restricted active evaluation range shortens the evaluation time for fast applications, for example, because the evaluation routine only has to take account of unblanked parts of the scan line. The range is restricted by entering appropriate values for MINIMUM READING ANGLE and MAXIMUM READING ANGLE in the DISTANCE CONFIGURATION tab.

The CLV490 does not output a reading result in this mode.

Show RA-limits enables you to check whether

- The visible range of the CLV490 has been defined accordingly for the selected setting in autofocus mode (restriction is independent of reading distance and always the same)
- The restriction has been adapted for each active distance configuration in event-controlled dynamic focus control ("Christmas tree" effect)

Show RA-limits can be called up via VIEW in the menu bar, as a device function via CLV490 (interactively), or via the Terminal Emulator.

Line scanner with oscillating mirror:

In "Show RA-limits" mode, the CLV490 behaves in the following manner:

- in "Oscillating" mode (default setting: oscillating with a fixed amplitude), the CLV490 shuts off oscillation and positions the scan line under the angle $CW = 50$ (corresponds to an angle of deflection below 105°). This position cannot be altered.
- in "One-Shot" mode, the CLV490 positions the scan line under the angle $CW = 50$.
- in "Fixed Position" mode, the scan line's selected position remains unchanged.

The CLV490 blanks the scan line alternately as of the set value for RA_{min} and as of the set value for RA_{max} . Fig. 6-13 shows an example of this. The switchover is made continuously at intervals of 1 second. The part of the scan line that remains active for the reading procedure is the section between RA_{min} and RA_{max} .

Example:

Default setting: $RA_{min} = 5$ to $RA_{max} = 95$.

The CLV490 blanks the line as of $RA_{min} = 5$ (short scan line) and as of $RA_{max} = 95$ (long line).

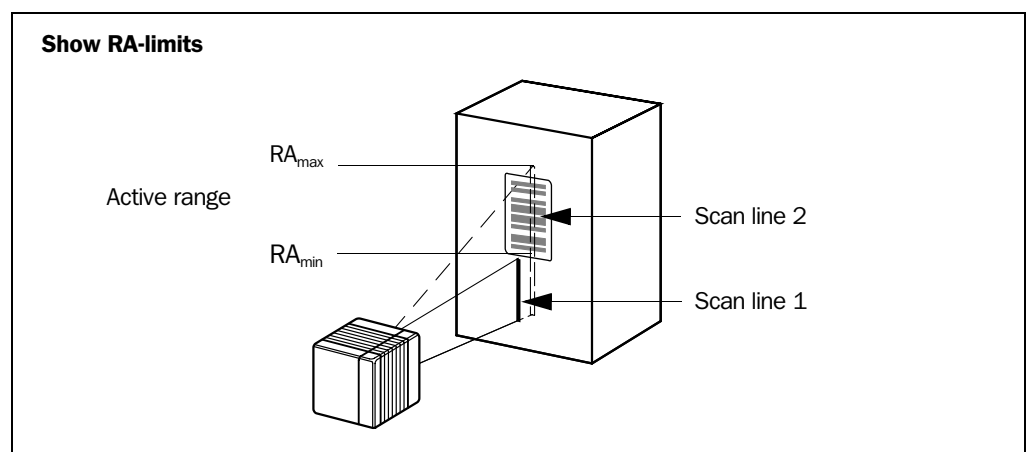



Fig. 6-13: Appearance of scan line in the "Show RA-limits" mode



Proceed as follows to check the restricted evaluation range:

1. Click  in the toolbar.
The Terminal Emulator window is then displayed. The CLV490 is in the Reading mode.
2. In the DEVICE MODE section, choose SHOW RA-LIMITS.
The dialog box for the distance configuration is then displayed.
3. Click the distance configuration for which the active evaluation range of the scan line has been restricted (DC-specific). The "Device Ready" LED is extinguished. The CLV490 cancels the Reading mode and blanks the red scan line alternately (as described above) as of RA_{min} and RA_{max} .
4. Check *Step 2 and 3* for each active distance configuration to determine whether the bar code is in the center of the range between the end of the shorter scan line (RA_{min}) and the end of the longer scan line (RA_{max}) or, if there are several bar codes, to determine whether the center of the field of all the codes is within the range.
5. If necessary, correct RA_{min} and RA_{max} accordingly. Perform a download to the CLV490!
6. Choose READING MODE to exit the Show RA-limits mode. The CLV490 returns to the Reading mode and the "Device Ready" LED lights up.

Note In the Reading mode, the CLV490 does not actually blank the scan line visually, but instead takes the values specified for the restricted evaluation range into account when the data contents are decoded.

6.5.6 Background Analysis

In this mode, CLV-Setup shows online how the CLV490 interprets the object distance measurement of its visual range. This function provides information on the gradient of the current detected background (current distance profile), the background which was corrected via parameterizing/Background Teach-in and the points in the distance profile focused on by the CLV490. The object distance measurement must be activated for this (default setting).

- Click  or choose CLV490, BACKGROUND ANALYSIS in the menu bar.
The BACKGROUND ANALYSIS dialog box is displayed and shows the values in the plot diagram. The red line shows the current distance profile, the blue line shows the corrected background.

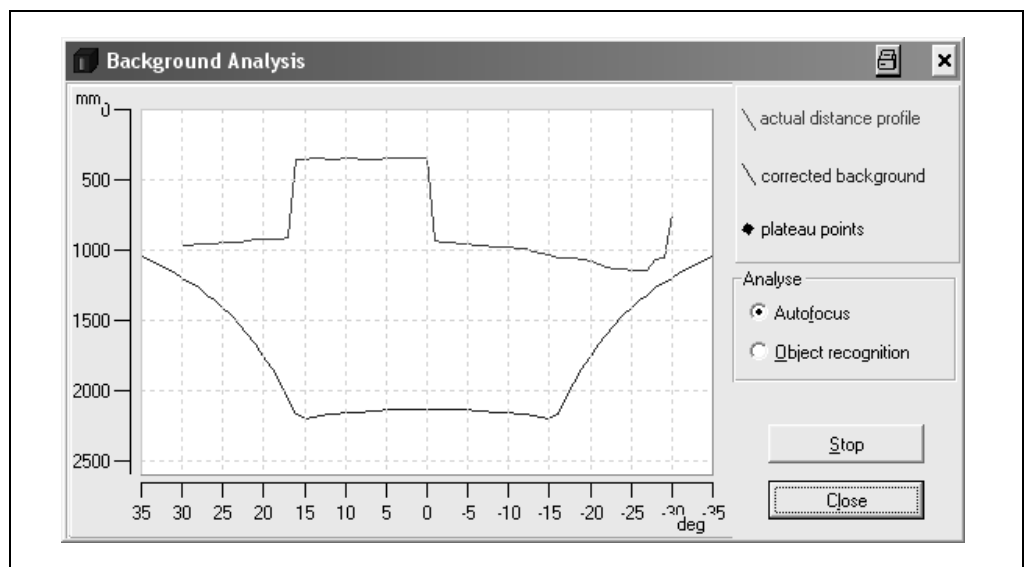

Fig. 6-14: CLV-Setup: Example of output in the "Background Analysis" dialog box

Choosing displayed curves

- To check the parameterization of the autofocus function of the CLV490, activate the AUTOFOCUS checkbox in the ANALYSE section.
We recommend that just the background without object be viewed with the function first, and then check whether the CLV490 has correctly focused on the object after it is brought into the foreground.
- To check the parameterization of the object polling function of the CLV490, activate the OBJEKT RECOGNITION checkbox in the ANALYSE section.
If the CLV490 detects a current object, the diagram displays an object detection marker (rhombi).
Test: Remove the object. The CLV490 must not focus, also not to the background.

Starting/Stopping updating

CLV-Setup polls the CLV490 once per second for the current distance profile (red) of the scan line in order to update the display.

1. To "freeze" the curves temporarily for viewing, click the STOP button.
CLV-Setup interrupts the updating process.
2. To continue, click the START button.
CLV-Setup continues updating.

The curves for the corrected background (blue) are static and are only polled once when the dialog box is opened.

Zooming in on area of plot diagram

Any area of the plot diagram can be enlarged (zoomed in) by selecting it with the mouse (hold down the left mouse button and drag the cursor to form a rectangle). Pressing the right mouse button returns to the plot diagram at the normal output size.

6.5.7 I/O monitor in increment trigger

Function of the **auxiliary interface**. In this mode, CLV-Setup displays the conditions of the various switching inputs/outputs of the CLV490 and any data transfer via the host interface. This is done in a dialog box and is time-independent of the increment trigger. Increment signals to the switching input "IN 4" of the CLV490 in the "Tracking" reading mode are required here. The display is continuous; the monitored signals are recorded. After the monitor is called up, the display is started by the next data output from the CLV490.

The display function in CLV490-Setup can be used for troubleshooting when starting up or when malfunctions occur during operation, as it supplies a convenient overview of the system condition at each moment. The function itself has no effect on the CLV490, apart from the temporary change of the auxiliary interface operating mode.

The inputs, outputs and direction of data transfer which is to be monitored can be selected. The display sequence of the signals in the plot diagram can be changed. Up to 15 signals can be displayed one under the other at the same time. The contents of the data output or data reception of the host interface is displayed separately without protocol characters in two output fields. The configured signal selection/sequence remains until CLV-Setup is ended so that the monitor can be called up again without needing to be reconfigured.

Configuring and calling up I/O monitor for display



1. In the symbol bar, click  or select CLV490, I/O MONITORING in the menu bar. The SIGNAL CHOICE dialog box is then displayed (Fig. 6-15).
2. Select the desired input, output or data transfer direction for each selection (entry) on the left side in one of the drop-down lists.
3. Click the ADD button.
The previously selected entry appears at the end of the list in the SIGNALS TO PLOT field to the right.
4. Repeat for other entries. A signal cannot be selected twice.
5. If necessary, delete undesired inputs, outputs or a data transfer direction from the list. Select the relevant entry and click the REMOVE button. Several entries can be chosen selectively by holding down the [CTRL] key and selecting with the left mouse button. A block selection is done by holding down the [SHIFT] key and selecting with the left mouse button.
6. If the sequence in the list is to be changed, select the desired entry and move it to the preferred location using the "up arrow" and "down arrow" buttons. Several entries can be moved selectively or as a block at the same time here as well.

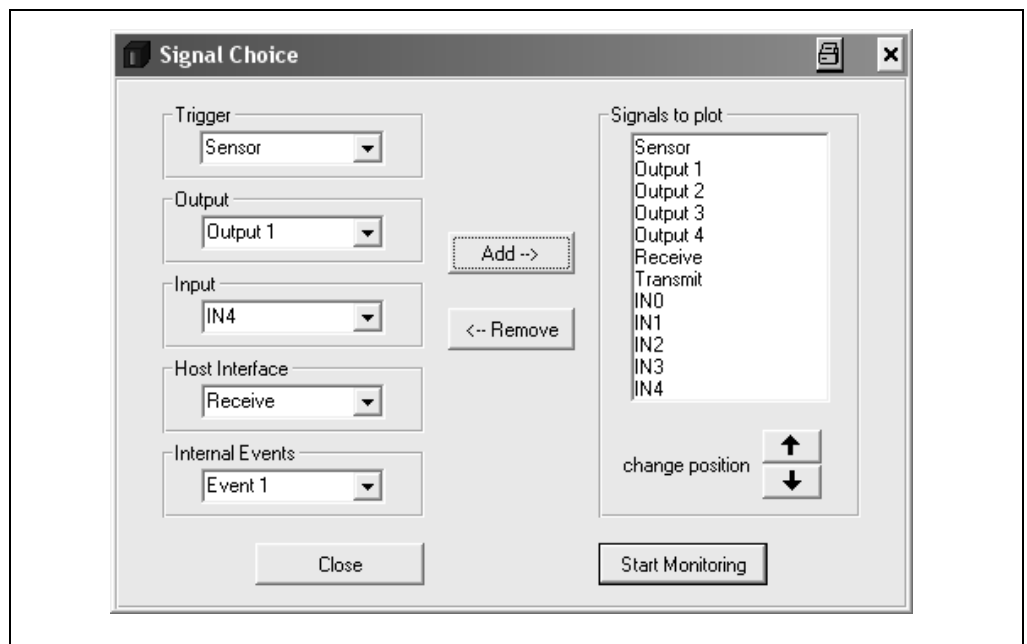

Fig. 6-15: CLV-Setup: Selection of the signals to be displayed in I/O Monitoring

7. After configuration is complete, click START MONITORING.
CLV-Setup begins with the display of the switching statuses/data output in the I/O MONITORING dialog box as soon as data is output from the CLV490. An example is shown in Fig. 6-16.
8. To cancel the display, click CLOSE in the I/O MONITORING dialog box and exit the SIGNAL CHOICE dialog box by clicking CLOSE.

– or –

Click EXIT in the I/O MONITORING dialog box.

CLV-Setup resets the operating mode of the auxiliary interface to its original function. This also applies when the SIGNAL CHOICE dialog box is exited with CLOSE without having started the I/O Monitor.

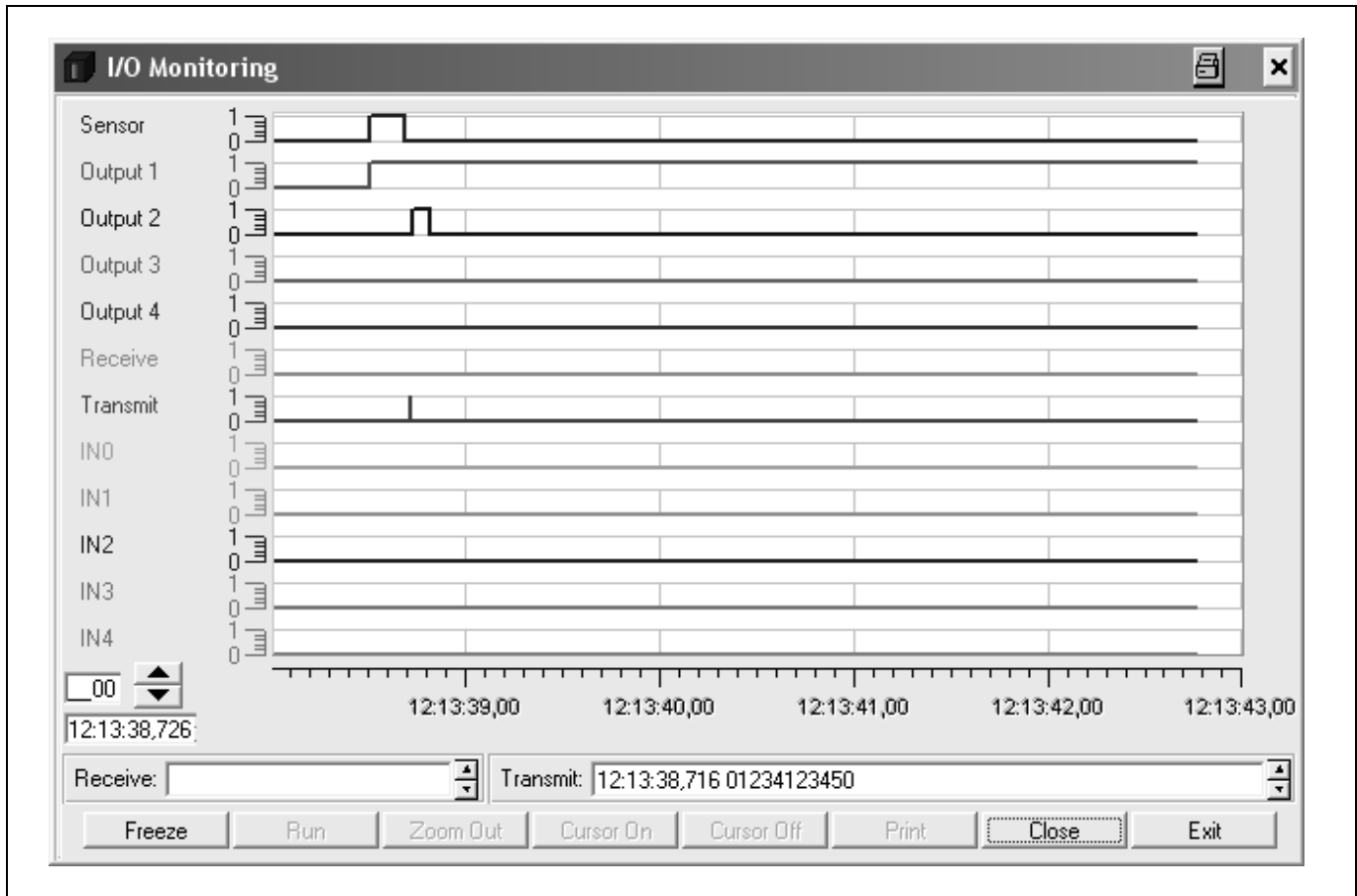

Fig. 6-16: CLV-Setup: Example of output in the "I/O Monitoring" dialog box

a) RUN mode

After opening, the dialog box automatically displays the switching conditions (high, low), their result-dependent changes and the data communication of the host interface as a marker in the plot diagram. This is done continuously. The selected signals and potentials (1 = high, 0 = low) are listed on the y axis, and the current time down to the 10 ms is listed on the x axis. When the recording reaches the right edge of the window, the screen is scrolled to the right 30 %.

The current increment status is located on the bottom, left-hand side next to the arrow buttons. The time stamp of the last time at which an event occurred is located below this. In the RECEIVE output field, CLV-Setup displays the contents of the data string which was last received via the host interface by the CLV490. A time stamp is displayed next to this. The TRANSMIT output field identifies the contents of the data string which was last sent by the CLV490. A time stamp is displayed next to this. Other functions are not possible in this mode of just the display.

b) STOP mode

This mode is used for the selective display and printing of events and measurement.

- Click the STOP button.
CLV-Setup cancels the continuous display in the plot diagram and the fields, but continues to record in the background.
A small table for displaying measured values appears.

Scrolling through events:

A scroll bar will appear to allow scrolling to previous events in the plot diagram which are not visible in the display. The large arrow buttons on the bottom, left-hand side also enable scrolling through the events (down arrow: backward in time, up arrow: forward in time). The arrows next to both output fields control the display of data strings.

Zooming in on area of plot diagram:

Using the XY cursor, selected areas of the plot diagram can be enlarged (zoomed in).

1. Click the CURSOR ON button.
The XY cursor appears.
2. Position the XY cursor anywhere in the plot diagram and, holding down the left mouse button, drag the cursor to form a rectangle containing the area to be enlarged.
3. Release the mouse button.
The selected area is enlarged and adjusted to fit the dialog box. In addition, a vertical scroll bar appears on the right side of the dialog box. A section can be enlarged with up to six levels of magnification. The signal names remain unchanged; the colors can be used to differentiate between the conditions in the plot diagram.
4. To reduce the zoom factor to the output level, click the ZOOM OUT button as many times as is needed.
5. Click the CURSOR OFF button to hide the XY cursor.

Calling up a specific event and accompanying data:

Clicking the left mouse button in the plot diagram causes CLV-Setup to display the event which is closest to the x position of the cursor in all output fields (exception: measured value table). This allows the accompanying data of a data string to be called up selectively to the Receive or Transmit output field. The time and increment status of a rising or falling signal edge can be called up as well.

If the mouse pointer is located directly between two events when clicked, the event which occurred first is displayed.

Measuring increment status and time differential in plot diagram

Using the measured value table which appears, measurements can be made within the visible range of the plot diagram. Two measurement cursors are available for this purpose. They are activated/deactivated with the right mouse button.

1. Place the mouse pointer over the plot diagram and press the right mouse button.
The first measurement cursor appears.
2. Place the measurement cursor on an edge of one of the signals.
The corresponding time and the increment status of the first event are displayed in the output fields INCREMENT 1 and TIME 1 of the table.
3. Press the right mouse button again.
The second measurement cursor appears.
4. Place the measuring cursor to the right of the first measuring cursor on an edge of the same signal or of another angle which you are interested in.
The corresponding time and the increment status of the second event are displayed in the output fields INCREMENT 2 and TIME 2 of the table.
In addition, the time differential and the increment differential are displayed in the DELTA INC and DELTA TIME output fields.

Pressing the right mouse button again or scrolling through the display clears both measuring cursors, and the table disappears.

Placing the second measurement cursor to the left (previous point in time) of the first measurement cursor is not permitted. If this is attempted, the first measurement cursor which was set and the table contents are cleared. A cursor cannot be placed outside the visible range of the plot diagram. An event which cannot be seen can appear in the measured value table, however.

Printing contents of window:

This function enables the signal conditions which were just displayed in the window to be printed out as a window with the designations of the plot diagram axes. The printout also contains the corresponding values of the increment status, time stamp, measured value table and contents of the data strings of both output fields.

1. Click the PRINT button.
The dialog box for printing is displayed.
2. Activate the relevant entries and confirm with OK.

Returning to RUN mode:

- Click the START button.
CLV-Setup returns to the continuous display of the signal conditions. Any enlargements of areas of the plot diagram are undone.

6.5.8 Displaying and editing operating data



This function enables statistical operating data, which the CLV490 maintains in the form of counters during the reading procedure, to be displayed and reset.

The CLV490 does not output a reading result in this mode.

1. Click  in the tool bar.
The CLV490 cancels the Reading mode and the "Device Ready" LED is extinguished. The OPERATING DATA dialog box appears (Fig. 6-17).
2. After checking/resetting the desired counters, click OK to confirm any changes made. The CLV490 then returns to the Reading mode and the "Device Ready" LED lights up.

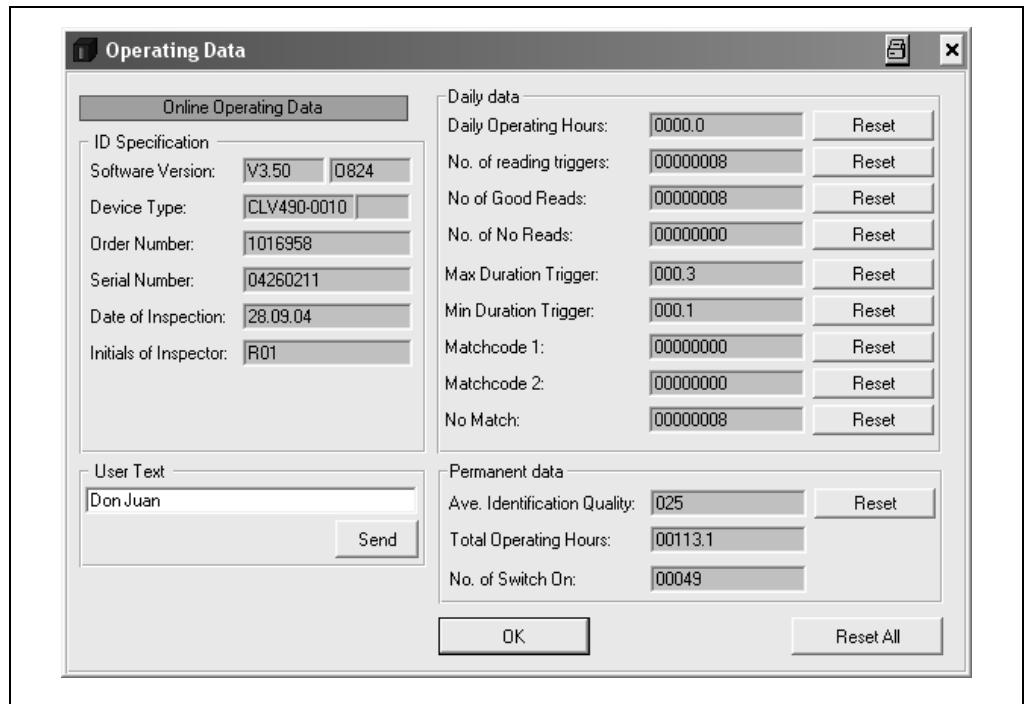

Fig. 6-17: CLV-Setup: "Operating Data" dialog box

6.5.9 Reading diagnosis

Function of the **auxiliary interface**. In this mode, the CLV490 outputs the data contents of all the bar codes that were read – including those that, according to the evaluation criteria, were not read properly and were thus incorrect – together with the associated reading diagnosis data via the auxiliary interface. The number of bar codes output can, therefore, be higher than the number of those that were sent via the host interface in the reading result. In the default setting, this mode is selected for the auxiliary interface.

Fig. 6-8, Page 6-40 shows the output format of the auxiliary interface.

In the default setting, the CLV490 does not output any reading diagnosis data via the host interface.

If the reading diagnosis is to remain inactive, this can be set via the AUXILIARY INTERFACE tab.



1. In the AUXILIARY INTERFACE drop-down list, choose READ DIAGNOSTICS.
2. Perform a download to the CLV490 by clicking  in the toolbar. The DOWNLOAD PARAMETERS dialog box is then displayed.
3. Choose the PERMANENT storage option in the dialog box.

The auxiliary interface is now set to the "Read Diagnostics" mode.

6.5.10 Monitor Host Interface

Function of the **auxiliary interface**. In this mode, the CLV490 outputs the data traffic of its host interface via the auxiliary interface. Protocol driver handshakes and protocol-specific data, such as start and stop characters, are suppressed here. Each data string is displayed on a separate line on the screen. Two monitoring modes are available that differ with regard to the data output format (*Table 6-25*).

Mode	Direction of data	Output format	Representation on screen
"Monitoring host interface"	CLV490 receives from host CLV490 sends to host	<STX> I Data <CR> <LF> <ETX> <STX> O Data <CR> <LF> <ETX>	I Data O Data
"Monitoring host interface 2"	CLV490 receives from host CLV490 sends to host	<STX> Data <ETX> <STX> Data <ETX>	Data Data

Table 6-25: "Monitor Host Interface" function



The MONITOR HOST INTERFACE or MONITOR HOST INTERFACE 2 function is activated via the AUXILIARY INTERFACE tab.

1. In the AUXILIARY INTERFACE drop-down list, choose MONITOR HOST INTERFACE or MONITOR HOST INTERFACE 2.
2. Perform a download to the CLV490.
To do so, click the desired option in the list again with the right mouse button and choose DOWNLOAD PARAMETER in the context menu.
CLV-Setup copies the parameter to the CLV490 temporarily.
The auxiliary interface then operates in the choosed "Monitor Host Interface" mode until the CLV490 is switched off again.

Note On good read, the CLV490 only outputs the number of read bar codes being defined for maximum on the CODE CONFIGURATION tab, in the NUMBER OF CODES section.



Displaying the data traffic of the host interface in the Terminal Emulator:

The data traffic of the host interface can be displayed in the Terminal Emulator of CLV-Setup. Fig. 6-18 shows an example of how the reading result can be output.

1. Choose the serial interface as the external trigger source for the reading pulse. See [Chapter 6.5.1 Reading mode \(standard operating mode\)](#), Page 6-38.
2. Click  in the toolbar. The Terminal Emulator window is then displayed. The CLV490 is in the Reading mode.
3. Click on the SW-TRIGGER ON button or press [F7]. The red scan line then appears.
4. Present the bar code pattern from [Fig. 6-1, Page 6-4](#).
5. Click the SW-TRIGGER OFF button or press [F8]. CLV-Setup outputs the reading result in the Terminal Emulator. Example: "O 0123412345".

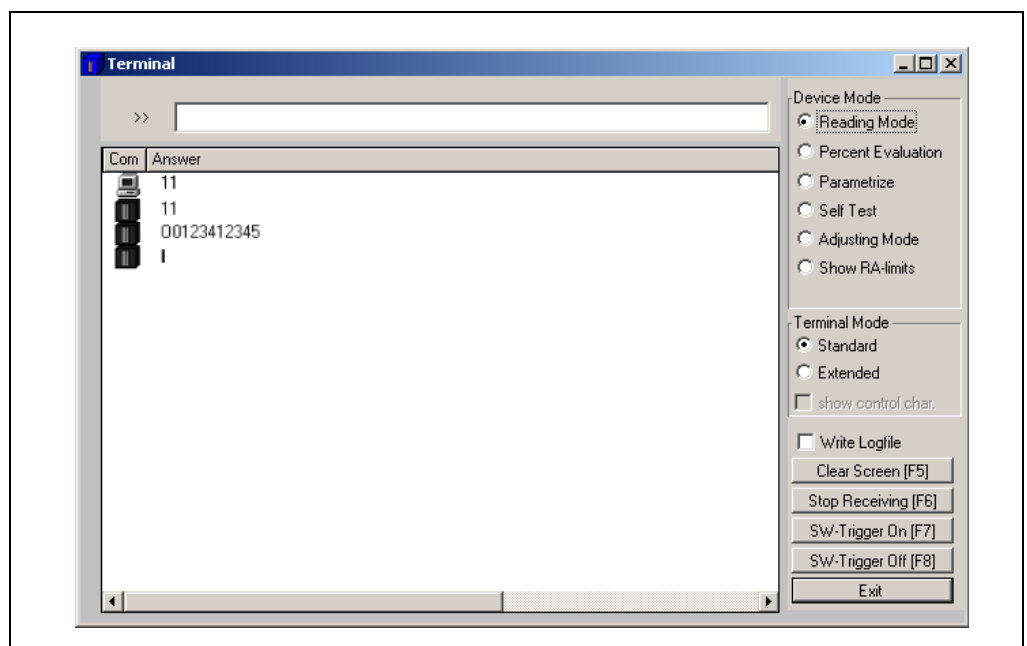

Fig. 6-18: CLV-Setup: Displaying the reading result of the host interface in the Terminal Emulator with direction identifier at the beginning (in this case: O = Output)

Note If a large amount of data is being read in at high speed and with a high transmission rate, the host interface's data trafficking may no longer be completely displayed on the auxiliary interface (display "..."). This is due to the slower transmission rate of the auxiliary interface (9,600 bd).

In the default setting, the CLV490 sends the following in the data output string of the host interface:

- On Good Read: Data content of one bar code
- On No Read: Character string "NOREAD"

The "Header", "Code-Info/Separator", "Splitter" und "Terminator" blocks are blank.

**Tip**

The structure of the data output string of the host interface can be configured via the DATA STRINGS tab.

- Up to 10 elements, consisting of constants (letters, digits, control characters) and/or reading diagnosis data, can be entered in the "Header", "Code-Info/Separator", "Splitter" und "Terminator" blocks.
 - Up to 5 elements, consisting of constants (letters, digits, control characters) can be entered in the "Splitter" blocks.
 - The position of the "Code-Info/Separator" block can be chosen before or after the code.
1. Choose the DATA STRINGS tab.
 2. Click the HEADER field.
The EDIT PARAMETER: TFH dialog box is then displayed.
 3. Click the desired constants or placeholders for the reading diagnosis data.
The selected elements appear in the text box at the top of the dialog box in the sequence in which they were selected.
 4. Confirm the entries made by clicking OK.
 5. Repeat this procedure for the "Code-Info/Separator", "Splitter" und "Terminator" blocks.
 6. Perform a download to the CLV490 by clicking  in the toolbar.
The DOWNLOAD PARAMETERS dialog box is then displayed.
 7. Choose the PERMANENT storage option in the dialog box.
The CLV490 outputs the selected elements in the data output string of the host interface with the next reading result.

6.5.11 Auxiliary input

Function of the **auxiliary interface**. In this mode, the CLV490 accepts a bar code entered at the auxiliary interface (via the keyboard or hand-held scanner with decoder). It sends the bar code to the host in a separate data string via its host interface. No reads can, therefore, be corrected by transmitting missing bar codes subsequently.

[Chapter 10.11.1 Auxiliary input via auxiliary interface, Page 10-69](#) describes this function and the associated procedure in greater detail.

6.5.12 Code statistics for RDT400

Function of the **auxiliary interface**. The CLV490 outputs a data string with statistic information of the reading situation in this mode.



For an deailed description of the functions and applications of the Remote Diagnostic Tools RDT 400, see the *RDT400 Operating Instructions* (no. 8009385, English edition).



"Code statistics for RDT400" is activated via the AUXILIARY INTERFACE tab.

1. Select the Code Statistics option for RDT400 on the AUXILIARY INTERFACE tab.
2. Perform a download to the CLV490.
To do so, click the RDT400 option again with the right mouse button and choose DOWNLOAD PARAMETER in the context menu.
CLV-Setup copies the parameter to the CLV490 temporarily.
The auxiliary interface then operates in "Code statistics for RDT400" mode until the CLV490 is switched off again.

6.5.13 Self-test

After the CLV490 has been switched on, it performs a self-test before it is initialized with the parameter set. The test can be called up explicitly at any time via CLV-Setup. During the self-test, the CLV490 checks that its hardware components are functioning correctly. A final message via the auxiliary interface provides information on the test result. The CLV490 does not output a reading result during the test routine.



1. Click  in the toolbar.
The Terminal Emulator window is then displayed. The CLV490 is in the Reading mode.
2. In the DEVICE MODE section, choose SELF TEST.
The "Device Ready" LED is extinguished. The CLV490 cancels the Reading mode and starts the test routine.
After a few seconds, the CLV490 outputs the encoded test result in the form of a code number (Fig. 6-19).
3. To return to the Reading mode, click READING MODE or close the Terminal Emulator.
The CLV490 then returns to the Reading mode and the "Device Ready" LED lights up.

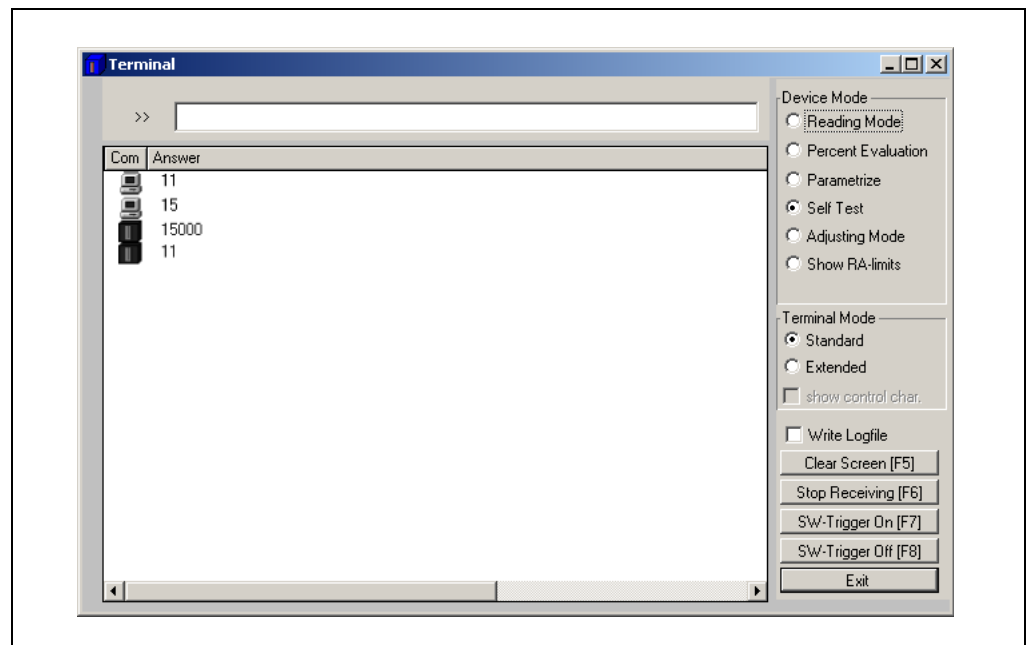

Fig. 6-19: CLV-Setup: Displaying the self-test result in the Terminal Emulator

The code number "15000" means that the self-test was completed successfully and that no faults were diagnosed. [Chapter 8.3.1 CLV490 without external parameter memory, Page 8-2](#), lists the error keys together with the associated corrective measures.

6.5.14 Executing CLV490 functions interactively

CLV-Setup enables a number of CLV490 functions to be executed interactively. CLV-Setup prompts the user to carry out specific actions and provides information on the progress of the function being executed.

The following functions are available:

- Background teach-in/reset (to default)
- Percentage evaluation
- Show RA-limits
- Adjustment mode
- Copy parameter memory (internal -> external, external -> internal)
- Analyze CAN Scanner Network
- Activate factory defaults in device

➤ Choose CLV490, DEVICE FUNCTIONS and the desired function

– or –

press the [F2] key.

The EXECUTE DEVICE FUNCTIONS dialog box is then displayed.

Choose the desired function in the EXECUTE menu in the menu.

CLV-Setup starts the function and, where appropriate, prompts the user to carry out the necessary actions.

6.6 CLV490 messages

The CLV490 outputs encoded system and error messages via the auxiliary interface to report user actions or events in the reading process. When the system is started, the CLV490 also outputs system messages in plain text (English). If configured accordingly, the CLV490 transfers the error status ST in the data output string of the host interface.

6.6.1 Displaying messages

In the 4th field from the left in the status bar at the bottom of the screen, CLV-Setup displays system and error messages that occur at the auxiliary interface of the CLV490. These are recorded in a file, which is continuously updated. The messages have the following format:

- System message: "CLV SYS-Message: xxx"
- Error message: "CLV SYS-Failure: xxx"

The additional system messages in plain text can be displayed in the terminal emulator if CLV-Setup and the terminal emulator are started before the CLV490 is connected.

Additional messages:

When the system is started, these system messages inform the user whether the starting process was successful. No further measures are normally required.

[Chapter 10.5 System messages, Page 10-42](#) explains the meaning of the messages.

6.6.2 Error messages

Error messages indicate the following types of error:

- a device defect
- incorrect parameter settings
- errors during data transmission to the host

[Chapter 8.3 Error messages, Page 8-2](#) lists the messages with the associated corrective measures.

Note To call up the most recent error to occur in the CLV490, enter command "2?SF" in the command line of the terminal emulator.

6.7 Switching off the CLV490

1. If the parameter set was modified in CLV-Setup or was only stored temporarily in CLV490 via a download ("Temporaray" option or via context menu (right mouse button)), the parameter set must be stored permanently in the CLV490 by choosing the PERMANENT storage option.
2. Save the parameter set as a configuration file "*.scl" in CLV-Setup.
3. Switch off the power supply of the CDM490 or unplug both of the CLV490's connecting cables from the connection module.

The last parameter set stored permanently in the CLV490 remains valid.

Archiving the parameter set:

We recommend that you print out the configuration file in order to archive the parameter set.

1. Click  in the toolbar.
The PRINT FILE dialog box is then displayed.
2. Enter a comment in the input field in order to assign the printout to the CLV490.
Confirm your entry with OK.
The PRINT dialog box for configuring the printer is then displayed.
3. Make the necessary entries in the dialog box and confirm these.
CLV-Setup prints out the current configuration file in the form of a table.

7 Maintenance

7.1 Maintenance during operation

The CLV490 functions maintenance free. Regular maintenance is not required to guarantee laser class 2 of the CLV490.

Note **Don't open the device. The warranty will be forfeited if the device is opened.**

The CLV indicates any faults or malfunctions by outputting coded system and error messages (e. g. "CLV SYS-Failure: 081") via its auxiliary interface. The messages are displayed in the "CLV-Setup" program window in the fourth field from the left on the bottom, in the status line (see also [Chapter 8.3 Error messages, Page 8-2](#)). CLV-Setup logs the messages in a file.

7.2 Cleaning the CLV490

Recommendation In order to make use of the full optical reading capacity of the CLV490, the reading window should be checked regularly (e. g. weekly) for soiling. This is especially recommended when operating the device in harsh conditions (dust, abrasion, humidity, finger prints, etc.).

7.2.1 Cleaning the front window



Laser beam can cause blindness.

The CLV490 uses a class 2 red-light laser. Looking directly at the laser beam can seriously damage your eyesight.

- Never look directly into the path of the beam (similar to sunlight).
- Switch off the device while it is being cleaned.
- Never look directly into the reading window while the device is in operation.



Damage on the reading window

The reading window is made of glass. Scratches and streaks on the window will reduce the reading performance.

- Do not use aggressive cleaning agents.
- Do not use cleaning agents which cause increased abrasion (e. g. powder).
- Avoid cleaning motions at the reading window which could cause scratches or abrasion

Cleaning the reading window:

Note Electrostatic charges cause dust particles to stick to the reading window. This effect can be combated by using anti-static SICK synthetic cleaner (no. 5600006) in combination with a SICK lens cloth (no. 4003353).

- Use a clean, soft brush to free the reading window ([Fig 7-1, Page 7-2](#)) from dust.
- If necessary, additionally clean the reading window with a clean, damp, lint-free cloth and a mild, anti-static window cleaning fluid.

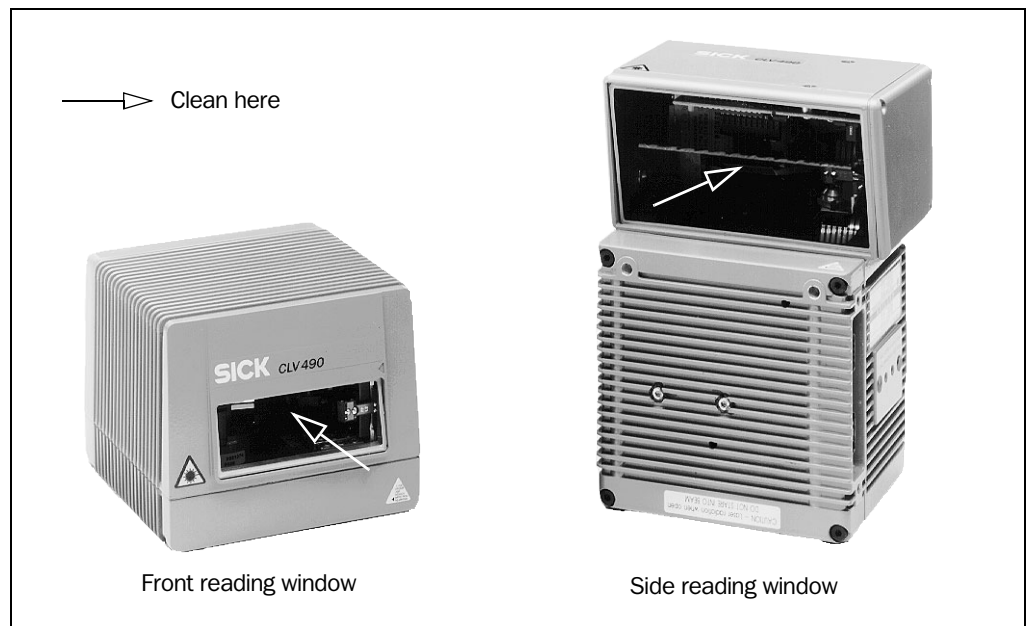

Fig. 7-1: Cleaning the reading window

If the reading window is scratched or damaged (cracked, broken), it must be replaced. Please contact the SICK Service.

Cleaning the housing

In order to ensure sufficient cooling for the CLV490, make sure that the housing is always clean.

- Use a soft brush to free the housing from dust.
- If necessary, clean the LEDs on the rear of the device.

7.2.2 Cleaning other optical surfaces

If an external reading pulse generator and/or object-height detection sensors are used (e.g. photoelectric reflex switches), further sensors with optical effective surfaces can be installed. Soiling of these surfaces can cause incorrect switching behaviour.

- In order to prevent incorrect switching behaviour, remove soiling from the optical effective surfaces of the external sensors.

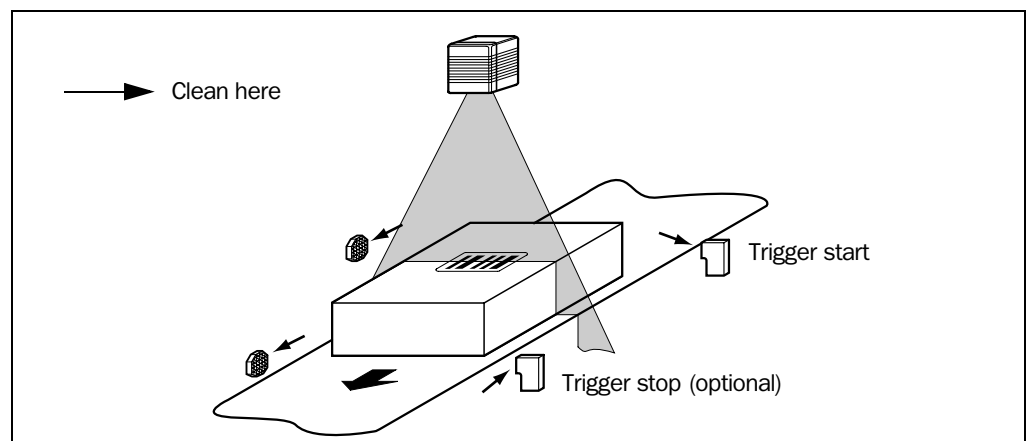

Fig. 7-2: Cleaning the external optical sensors (reading pulse generator, object-height detector)

7.3 Checking the incremental encoder

If an incremental encoder is used, check the correct position on the conveyor.

- Ensure that the incremental encoder always contact the conveyor so that the friction wheel turns without slipping.

7.4 Disposal

Irreparable devices or devices that are no longer required must be disposed of in an environmentally-friendly manner:

1. Always observe the applicable national waste disposal regulations.
2. Remove the CLV490 housing.
3. Remove the electronic modules.
4. Send the chassis and cover (aluminium) to be recycled.
5. Send the electronic modules for disposal as problem waste.

At present, SICK AG does not accept any unusable or irreparable devices.

Notes:

8 Troubleshooting

8.1 Overview of possible errors and malfunctions

8.1.1 Mounting errors

- CLV490 aligned incorrectly with the object carrying the bar code (e. g. blanking)
- Reading pulse sensor positioned incorrectly (e. g. internal reading interval starts too soon or too late)
- With event-controlled focus control: sensors for object height detection positioned incorrectly

8.1.2 Electrical installation errors

- Interfaces on the CLV490 connected incorrectly (wiring error in CDB420 or CDM490)

8.1.3 Parameter errors

- Functions not adjusted to local conditions, e. g. communication parameters on the host interface are set incorrectly
- Technical limits of the device exceeded, e. g. relationship between the scanning frequency and the reading distance

8.1.4 Malfunctions

- Start/stop mode: no external reading trigger, more than one object in the reading field
- Tracking mode: gap between the objects in conveying direction fallen below minimum
- Laser timeout for incorrectly terminated reading pulse exceeded
- Device error (hardware/software)

8.2 Monitoring error and malfunctions

The CLV490 is self-monitoring:

- After the power supply has been switched on, the CLV490 automatically carries out a self-test, in which it checks important hardware components, before it is initialized (parameter set loaded and device functions initialized). The self-test can be repeated at any time by cancelling Reading mode. See [Chapter 6.5.13 Self-test, Page 6-57](#).
- If the CLV490 detects an error during the self-test or at any other time, it outputs the error status ST= 3 on the host interface. Prerequisite: the error status is enabled for transmission. This is disabled by default. The CLV490 displays the diagnosed error as a numeric combination via the auxiliary interface (see [Table 8-1, Page 8-2](#)).
- While it is in operation, the CLV490 constantly monitors the laser diode and speed of the polygon mirror wheel. In addition, a watchdog circuit responds to error statuses. The CLV490 carries out referencing at regular cycles. To do so, the laser diode is switched on for max. 10 s.
- A timer (laser timeout) automatically deactivates the laser diode in Reading mode ("Sensor input" and "Serial interface trigger" mode) if the reading interval has not ended after 10 minutes (default setting). However, it does not end the reading interval. In this case, the CLV490 outputs the message:
"Laser safety timeout"

on the auxiliary interface. The reading interval must be terminated by resetting the trigger signal. The laser diode is activated again by the next reading trigger.

8.3 Error messages

The CLV490 outputs coded error message (number combinations) via the **auxiliary interface** only. [Table 8-1](#) contains a list of the messages.

Displaying messages:

To display the messages on the PC, proceed as follows in CLV-Setup:

- Click  in the toolbar.
The Terminal Emulator is launched.

CLV-Setup logs the error messages automatically in a file (sys_msg.log).

8.3.1 CLV490 without external parameter memory

Message	Meaning	Possible cause	Remedy
"CLV SYS-Failure: xxx"	The CLV490 has diagnosed a system error. The "Device Ready" LED does not light up or extinguishes. The system is restarted.	Error key: ¹⁾ 011 Data error (RAM) 012 Address error (RAM) 013 RAM too small 051 Speed out of tolerance (mirror wheel) 061 Mirror interval out of tolerance 071 Error: laser shutter 091 to 095 Error: focus control 101 to 118 Error: external parameter memory 130 Amplifier error 131 Background profile invalid 132 Center reading angle RA 50 implausible 133 Brightness overflow 201 to 215 DSP error	If the error occurs again after the CLV490 is restarted, contact the SICK Service department.
<p>¹⁾ Deactivate the CAN interface to suppress error numbers above 300 (not relevant in stand-alone mode). To do so, upload the parameter set from the CLV490 using CLV-Setup, choose the CAN INTERFACE tab and deactivate the function in the CAN INTERFACE FUNCTION section. Download the parameter set to the CLV490!</p>			

Table 8-1: Error messages output on the auxiliary interface

8.3.2 LED error messages for the external parameter memory (connector cover)

The CLV490 also reports errors accessing the external parameter memory by means of the "Device Ready" and "Read Result" LEDs.

LED behavior	Meaning	Possible cause	Remedy
1. When the device is switched on, the "Device Ready" LED blinks for approx. 10 s and then lights up constantly.	Start option: START WITH EXTERNAL PARAMETERS. The CLV490 has successfully loaded the external parameter set to its RAM.	–	Not applicable.
2. When the device is switched on, the "Device Ready" and "Read Result" LEDs blink for approx. 10 s. The "Device Ready" LED then lights up constantly.	Start option: START WITH EXTERNAL PARAMETERS. The CLV490 has successfully loaded the external parameter set with tolerated errors ¹⁾ to its RAM.	Transfer ok, but different parameter versions in the external memory and CLV490.	Upload parameter set to CLV-Setup and check parameters ¹⁾ .
3. The "Device Ready" LED lights up constantly when the device is switched on.	<ul style="list-style-type: none"> Start option: START WITH EXTERNAL PARAMETERS. The CLV490 has not loaded external parameter set. Instead, it has loaded the internal parameter set to its RAM. Start option: START WITH INTERNAL PARAMETERS. The CLV490 has successfully loaded the internal parameter set to its RAM. 	<ul style="list-style-type: none"> External parameter memory not connected. Start ok. 	<ul style="list-style-type: none"> OK if the device is to be operated without an external parameter memory. Check whether the external parameter memory is connected correctly (free wiring: check wire assignment). None.
4. When the device is switched on, the "Device Ready" and "Read Result" LEDs blink continuously ²⁾ .	<ul style="list-style-type: none"> Start option: START WITH EXTERNAL PARAMETERS. The CLV490 has not loaded the external parameter set. Instead, it has loaded the internal parameter set to its RAM. The CLV490, however, does not output data on the host interface. 	<ul style="list-style-type: none"> External parameter memory not connected. The parameter set in the external memory is not from a CLV490. External parameter memory is defective. 	<ul style="list-style-type: none"> See 3 <i>Remedy</i>. Use the correct external parameter memory or overwrite the current one. Repeat the startup procedure. If the error is still present after following 4 <i>Remedy</i>, 1st and 2nd paragraph, contact the SICK Service department.

1) The software of the parameter set in the CLV490 is older than that of the parameter set in the external memory: print out the parameter set using CLV-Setup. If necessary, display the ID of the unknown/errored command group(s) using the <STX> 8?ERR <ETX> command in the Terminal Emulator window of CLV-Setup. Decode the ID using the reference manual entitled "Command Language of the CLV490 Bar Code Scanners" and check the relevant parameter values in the tabs.
The software of the parameter set in the CLV490 is newer than that of the parameter set in the external memory: all of the new parameters in the CLV490 are set to the default values. If these parameters are necessary, edit the values in the relevant tabs in CLV-Setup and download them to the CLV490 and the external memory.

2) Flashing stops when the device switches from Reading mode to Parameter mode (e. g. during download from CLV-Setup).

Table 8-2: LED error messages for access to the external parameter memory (connector cover)

LED behavior	Meaning	Possible cause	Remedy
4. When the device is switched on, the "Device Ready" LED and "Read Result" LEDs blink continuously ²⁾ . – <i>continued</i> –	<ul style="list-style-type: none"> Start option: START WITH COPY INTERN → EXTERN. The CLV490 was not able to copy the internal parameter set to the external memory. It has loaded the internal parameter set to its RAM. 	<ul style="list-style-type: none"> External parameter memory is not connected. Data transmission error. Internal parameter set too large to be copied to the external memory (memory is full). The external parameter memory is defective. 	<ul style="list-style-type: none"> Ensure that the external parameter memory is connected correctly (free wiring; check wire assignment). Repeat the startup procedure. If the error is still present after following 4 Remedy, 1st and 2nd paragraph, contact the SICK Service department. Contact the SICK Service department. See 4 Remedy, 3rd paragraph
5. When the device is switched on, the "Device Ready" and "Read Result" LEDs blink alternately for approx. 10 s. The "Device Ready" LED then lights up constantly.	Start option: START WITH COPY INTERN → EXTERN. The CLV490 has successfully copied the internal parameter set to the external memory ³⁾ and set the option for the next start to START WITH EXTERNAL PARAMETERS. It has loaded the internal parameter set to its RAM.	Transfer ok.	Not applicable.

2) Flashing stops when the device switches from Reading mode to Parameter mode (e. g. during download from CLV-Setup).

3) The parameter set stored in the external memory is not checked automatically to determine whether it can be read. To check the parameter set, switch off the power supply to the CLV490 briefly and monitor the "Device Ready" LED as described under 1.

Table 8-2: LED error messages for access to the external parameter memory (connector cover) (contd.)

8.3.3 Messages for errors accessing the external parameter memory (connector cover)

The CLV490 outputs further error messages, in addition to the general error messages in [Chapter 8.3.1 CLV490 without external parameter memory, Page 8-2](#), if problems arise when the external parameter memory is accessed.

Message	Meaning	Possible cause	Remedy
1. "error: access to external parameters not successful, internal parameters loaded" (Error type: 104, 105, 106, 111, 112,115)	<ul style="list-style-type: none"> Start option: START WITH EXTERNAL PARAMETERS. The CLV490 has not loaded the external parameter set. Instead, it has loaded the internal parameter set to its RAM. The CLV490, however, does not output data on the host interface. Start option: START WITH COPY INTERN → EXTERN. The CLV490 was not able to copy the internal parameter memory. It has loaded the internal parameter set to its RAM. 	The external parameter memory is defective.	Repeat the startup procedure. If the error is still present, contact the SICK Service department.
2. "error: external parameter memory full, internal parameters loaded" (Error type: 108)	Start option: START WITH COPY INTERN → EXTERN. The CLV490 was not able to copy the internal parameter memory. It has loaded the internal parameter set to its RAM.	The internal parameter set is too large for the external memory (memory is full).	Contact the SICK Service department.
3. "error: external parameters not valid for device, internal parameters loaded" (Error type: 116)	Start option: START WITH EXTERNAL PARAMETERS. The CLV490 has not loaded the external parameter set. Instead, it has loaded the internal parameter set to its RAM. The CLV490, however, does not output data on the host interface.	The parameter set in the external memory is not from a CLV490.	Use the correct external parameter memory or overwrite the current one.
4. "error: no external parameter memory connected, internal parameters loaded" (Error type: 102)	<ul style="list-style-type: none"> Start option: START WITH EXTERNAL PARAMETERS. The CLV490 has not loaded the external parameter set. Instead, it has loaded the internal parameter set to its RAM. Start option: START WITH COPY INTERN → EXTERN. The CLV490 was not able to copy the internal parameter set to the external memory. It has loaded the internal parameter set to its RAM. 	<ul style="list-style-type: none"> External parameter memory not connected. External parameter memory not connected. 	<ul style="list-style-type: none"> OK if the device is to be operated without an external parameter memory. Check whether the memory is connected correctly (free wiring; check wire assignment). See 4 Remedy, 2nd paragraph

Table 8-3: Messages for problems accessing the external parameter memory (connector cover)

Message	Meaning	Possible cause	Remedy
5. "error: writing parameters CLV -> EXT, internal parameters loaded" (Error type: 110, 111, 112)	Start option: START WITH COPY INTERN -> EXTERN. The CLV490 was not able to copy the internal parameter set to the external memory. It has loaded the internal parameter set to its RAM.	Data transmission error.	Check whether the external parameter memory is connected correctly (free wiring: check wire assignment). Repeat the startup procedure. If the error is still present, contact the SICK Service department.
6. "warning: additional unknown parameter(s), external parameters loaded" (Error type: 101, 114)	Start option: START WITH EXTERNAL PARAMETERS. The CLV490 has successfully loaded the external parameter set with tolerated errors ¹⁾ to its RAM.	Transfer ok but different parameter versions in the external memory and the CLV490.	Upload the parameter set to CLV-Setup and check the values ¹⁾ .
<p>1) The software of the parameter set in the CLV490 is older than that of the parameter set in the external memory: print out the parameter set using CLV-Setup. If necessary, display the ID of the unknown/errored command group(s) using the <STX> 8?ERR <ETX> command in the Terminal Emulator window of CLV-Setup. Decode the ID using the reference manual entitled "Command Language of the CLV490 Bar Code Scanners" and check the relevant parameter values in the tabs.</p> <p>The software of the parameter set in the CLV490 is newer than that of the parameter set in the external memory: all of the new parameters in the CLV490 are set to the default values. If these parameters are necessary, edit the values in the relevant tabs in CLV-Setup and download them to the CLV490 and the external memory.</p>			

Table 8-3: Messages for problems accessing the external parameter memory (connector cover) (contd.)

8.4 ST error status in the reading result of a bar code

Value	Meaning	Possible cause	Remedy
0	Good Read.	–	Not applicable.
2	No bar code of the enabled code type found according to the evaluation criteria.	<ul style="list-style-type: none"> No bar code in the CLV490's reading field during the reading pulse Code type/length in the CLV490 not enabled for decoding Reading window obstructed/dirty 	<ul style="list-style-type: none"> Synchronize the pulse of the CLV490 with the entry of a bar code into the reading field. Correct the code configuration parameters. Check the reading window.
3	Device fault.	Device fault.	Call up the self-test. See Chapter 6.5.13 Self-test, Page 6-57 . If result ≠ 15000: Contact the SICK Service department.
5	Required number of successful multiple reads for the bar code not reached.	<ul style="list-style-type: none"> Conveyor speed of the object is too high Scanning frequency is too low Ladder-type arrangement for bar code relative to the conveyor direction: code height (bar length) too poor Print quality too poor 	<ul style="list-style-type: none"> Check the conveyor speed. Adjust the scanning frequency. Check the code height. Check the print quality.
6	Master: Number of slave reading results does not match the parameterized number of slaves.	<ul style="list-style-type: none"> The parameterized number of slaves does not match the actual number of slaves available The master timeout is too short The data connection between the slaves and/or the master has been interrupted 	<ul style="list-style-type: none"> Check the entered number of slaves. Check the master timeout setting. Check the cables between the slaves and the master.
7	The source of the reading result is the auxiliary input via the auxiliary interface.	The bar code was not detected by the reading function of the CLV490, but was entered subsequently with the auxiliary function of the auxiliary interface and sent to the host in a separate data string.	–
9	The OUTPUT FILTER function is activated for the code comparison. The CLV490 has detected valid bar codes. However, these do not match the active match code(s).	The scanned object does not have a bar code that matches the specified match code.	–
A	The CHECK MAX. NUMBER OF CODES function is active. The number of valid bar codes detected by the CLV490 in Reading mode exceeds that specified under NUMBER OF CODES: MAXIMUM. It repeatedly outputs the defined error string until the number specified under NUMBER OF CODES: MINIMUM is reached.	One object in a set of objects with a constant number of bar codes, for example, contains more bar codes than defined in the application.	This message is used to indicate errors on the objects (e. g. check whether objects are homogeneous: mixed with incorrect objects).
D	The CODE 32 evaluation option is activated for Code 39. The CLV490 is attempting to interpret 6-digit C39 bar codes as C32 bar codes (output as 9-digit decimal values).	The read 6-digit bar code is not a C32 bar code. The CLV490 outputs the defined error string instead.	–

Table 8-4: Meaning of the ST error status in the reading result

Value	Meaning	Possible cause	Remedy
F	The CHECK MIN. NUMBER OF CODES function is active. The number of valid codes detected by the CLV490 in Reading mode is less than that specified under NUMBER OF CODES: MINIMUM. Instead of the code contents, it outputs the defined error string in the quantity defined under NUMBER OF CODES: MINIMUM	One object in a set of objects with a constant number of codes, for example, contains fewer codes than defined in the application.	This message is used to indicate errors on the objects (e. g. check whether objects are homogeneous: mix with incorrect objects).

Table 8-4: Meaning of the ST error status in the reading result (contd.)

8.5 Troubleshooting

The following are required for troubleshooting purposes using the tables below:

- These Operating Instructions
- Tools
- A tape measure (up to 3 m (9.84 ft))
- A digital measuring device (current/voltage measurement)
- A PC running CLV-Setup
- A 3-core RS 232 data cable (null modem cable), pins 2 and 3 crossed, e. g. no. 2014054

8.5.1 General malfunctions: CLV490 not ready

Malfunction	Possible cause	Remedy
The "Device Ready" LED is not lit. The "Result 1" output is not outputting a pulse (default setting: Device Ready)	After switching on the power supply: <ul style="list-style-type: none"> • The CLV490 has no power. • The CLV490 has diagnosed a device error during the self-test. During operation: <ul style="list-style-type: none"> • The CLV490 is not in "Reading" mode. • The CLV490 has deactivated the laser diode 10 min. (default setting) after the start of the current reading pulse (trigger mode: sensor input/serial interface). 	<ul style="list-style-type: none"> • Check wiring (power connector fitted securely to the CDM490 Connection Module). Measure voltage at pin 1 and pin 5. • Switch CLV490 off and on again. Does the LED light up? If not, contact SICK Service department • Return to Reading mode using the "CLV-Setup" program. See Chapter 6.5.1 Reading mode (standard operating mode), Page 6-38 • Terminate reading pulse. Check the reading pulse function. Supply new pulse. See Table 6-23, Page 6-36.

Table 8-5: Troubleshooting: restoring operation (Reading mode)

8.5.2 Malfunctions in Reading mode: reading trigger errors

- Check whether the "Device Ready" LED lights up.
If the LED does not light, see [Table 8-5, Page 8-9](#).

CLV490 in stand-alone configuration

Malfunction	Possible cause	Remedy
<p>1. Trigger mode: Sensor input (external sensor).</p> <p>The CLV490 cannot be clocked:</p> <ul style="list-style-type: none"> – the "Sensor" LED does not light up – the red scan line does not appear 	<p>Reading mode "Start/stop" or "Tracking ":</p> <ul style="list-style-type: none"> • Sensor not connected or connected to incorrect switching input. • If sensor supplied by CLV490: sensor not connected to ground potential. • Incorrect reading pulse source parameterized in the CLV490. • Polarity of switching input inverted • Incorrect debouncing of the switching input parameterized in the CLV490. • Photoelectric switch not aligned with the reflector (photoelectric proximity switch/ inductive sensor not dampened). • The object does not pass the reading pulse sensor for trigger start with the conveyor running. 	<ul style="list-style-type: none"> • Connect sensor to "Sensor" switching input. Check sensor wiring (see Fig. 5-5, Page 5-22). Measure output signal on sensor. • Insert jumper between pin 5 and pin 15 (CDM490: S 1 switch "SGND_GND") • In the "CLV-Setup" program: choose the DEVICE CONFIGURATION tab, READING TRIGGER SOURCE section: Sensor input selected? (active high: reading pulse starts when power applied, active low: reading pulse starts when power removed) • See <i>above</i>. • In the "CLV-Setup" program: choose the DEVICE CONFIGURATION tab, click the READING TRIGGER PARAMETERS button, DEBOUNCING SENSOR section: Time controlled: selected value too high? Track controlled: incremental encoder connected to "IN 4" switching input? • Align sensor. Check functioning • Install reading pulse sensor in front of the CLV490 in conveying direction. See also Chapter 4.4.2 Mounting the external reading pulse sensor, Page 4-11.

Table 8-6: Troubleshooting: reading trigger errors in Reading mode (CLV490 in stand-alone configuration)

Malfunction	Possible cause	Remedy
<p>2. Trigger mode: Serial interface</p> <p>The CLV490 cannot be clocked:</p> <ul style="list-style-type: none"> - the "Sensor" LED does not light up - the red scan line does not appear 	<p>Reading mode "Start/stop" or "Tracking":</p> <ul style="list-style-type: none"> • Incorrect reading pulse source parameterized in the CLV490. • Incorrect command used. • The CLV490 is not receiving any command strings on the data interface to start the reading interval. 	<ul style="list-style-type: none"> • In the "CLV-Setup" program: choose the DEVICE CONFIGURATION tab, READING TRIGGER SOURCE section: is "serial interface" selected? Serial Interface section: is the trigger type correct? • Use correct commands. Standard trigger: Start: <START> 21 <STOP> Stop: <START> 22 <STOP> - or - defined single characters (DEVICE CONFIGURATION tab, click the READING TRIGGER PARAMETERS button, SERIAL INTERFACE section). • For reading mode "Tracking": only start command required. • Check data connection to host. In the "CLV-Setup" program: choose the HOST INTERFACE tab. In DATA FORMAT section: are the correct interface type (hardware) and data format selected? INTERFACE PROTOCOL section: are the correct start and stop characters selected? Use the "CLV-Setup" program to check the host command strings: choose AUXILIARY INTERFACE tab. Choose MONITOR HOST INTERFACE function. See Chapter 6.5.10 Monitor Host Interface, Page 6-54. Download temporarily to the CLV490.
<p>3. Trigger mode: Object Polling</p> <p>The CLV490 does not trigger automatically:</p> <ul style="list-style-type: none"> - the "Sensor" LED does not light up - the red scan line does not appear 	<p>Reading mode "Start/stop":</p> <ul style="list-style-type: none"> • Incorrect reading pulse source parameterized in the CLV490. • Incorrect criteria for automatic object detection parameterized in the CLV490. • Incorrect position of the CLV490 referred to the object detection space parameterized in the CLV490. 	<ul style="list-style-type: none"> • In the "CLV-Setup" program: choose the DEVICE CONFIGURATION tab, READING TRIGGER SOURCE section: is "object polling" selected? • In the "CLV-Setup" program: choose the DEVICE CONFIGURATION tab, click the OBJECT POLLING PARAMETERS button: POLLING PROPERTIES section: are the correct values selected? OBJECT DETECT SPACE section: are the correct values selected? If necessary: are the correct SCAN ANGLE and/or OSCILLATING ANGLE LIMITATION selected? • In the "CLV-Setup" program: choose the DEVICE CONFIGURATION tab, click the SCANNER POSITION PARAMETERS button: are the correct values selected?

Table 8-6: Troubleshooting: reading trigger errors in Reading mode (CLV490 in stand-alone configuration) (contd.)

Malfunction	Possible cause	Remedy
<p>4. CLV490 does not respond to an external signal that ends the reading pulse (sensor input, serial interface)</p>	<p>Reading mode "Start/stop":</p> <p><i>Trigger mode: one external sensor</i></p> <ul style="list-style-type: none"> • Incorrect end of reading pulse parameterized in the CLV490. • No signal from the sensor at the "Sensor" switching input. <p><i>Trigger mode: two external sensors</i></p> <ul style="list-style-type: none"> • If "IN 4" switching input is chosen as trigger source for end of reading interval: no sensor connected or polarity inverted. • The object does not pass the reading pulse sensor for trigger start with the conveyor running. <p><i>Trigger mode: serial interface</i></p> <ul style="list-style-type: none"> • Incorrect command used. • Laser timeout exceeded. 	<ul style="list-style-type: none"> • In the "CLV-Setup" program: choose the DEVICE CONFIGURATION tab, click the READING TRIGGER PARAMETERS button. END OF READING INTERVAL section: is "generated by Trigger Source" selected? • Check wiring of the sensor (see Fig. 5-5, Page 5-22). Measure output signal of the sensor. • Connect sensor to the "IN 4" switching input. Check wiring of the sensor (see Chapter 5.5.7 Connecting the "Sensor" switching input, Page 5-22). Choose the DEVICE CONFIGURATION tab, ASSIGNMENT OF INPUTS section: is "IN 4" selected (active high or active low)? Click the READING TRIGGER PARAMETERS button, END OF READING INTERVAL section: is "generated by IN 4" selected? • Install reading pulse sensor in front of the CLV490 in conveying direction. See also Chapter 4.4.2 Mounting the external reading pulse sensor, Page 4-11 • See 2. Remedy • See remedy in Table 8-5, Page 8-9.
<p>5. CLV490 does not terminate the reading clock or terminate the clock too late</p>	<p>Reading mode "Tracking":</p> <ul style="list-style-type: none"> • Incremental encoder not connected or connected to the wrong switching input. • If incremental encoder supplied by CLV490: encoder not connected to ground. • Incorrect reading mode parameterized in the CLV490. • Incorrect resolution of incremental encoder parameterized in the CLV490. • No conveyor motion (CLV490 does not receive incremental signals). • Laser timeout exceeded. 	<ul style="list-style-type: none"> • Connect incremental encoder to the "IN4" switching input. Check wiring (Fig. 5-6, Page 5-23). Check the output signal of the incremental encoder. Choose the DEVICE CONFIGURATION tab, ASSIGNMENT OF INPUTS section: IN 4: "Conveyor increment" selected? • Insert jumper between pin 5 and pin 15 (CDM490: S 1 switch "SGND_GND"). • In the "CLV-Setup" program: Choose the DEVICE CONFIGURATION tab, READING TRIGGER SOURCE section: "Sensor Input" selected? INTERNAL TRACKING section: "active" selected? • In the "CLV-Setup" program: INTERNAL TRACKING section: "Distance per encoder pulse" correctly selected? • Start the conveyor. • See remedy in Table 8-5, Page 8-9.

Table 8-6: Troubleshooting: reading trigger errors in Reading mode (CLV490 in stand-alone configuration) (contd.)

CLV490 integrated in OTS400 Omni Tracking System

Malfunction	Possible cause	Remedy
<p>1. Trigger mode in the CLV490: OTS trigger</p> <p>Reading mode "Start/stop":</p> <p>CLV490 not triggered by the OTC400:</p> <ul style="list-style-type: none"> – the "Sensor" LED does not light up – the red scan line does not appear 	<ul style="list-style-type: none"> • Incorrect reading pulse source parameterized in the CLV490. • CLV490 not parameterized as Slave. • CAN interface incorrectly parameterized in the CLV490. • Sensors for start and stop of reading trigger: incorrectly connected to OTC400 or switching inputs incorrectly parameterized. • "Master/Slave" mode not selected in the OTC400. 	<ul style="list-style-type: none"> • In the "CLV-Setup" program: choose the DEVICE CONFIGURATION tab, READING TRIGGER SOURCE section: is "OTS trigger" mode selected? • In the "CLV-Setup" program: choose the DEVICE CONFIGURATION tab, click the TRACKING PARAMETERS button, RELEASE POINTS section: OBJECT RELEASE POINT/END OF READING FIELD/DATA OUTPUT section: "0 mm" selected? Check box "MASTER/SLAVE VIA OTC" activated? • Check: CAN INTERFACE tab, CAN INTERFACE FUNCTION section: "OTS slave" as well as "data transfer rate" selected in accordance to OTC400? • Check connection and parameterization of switching inputs, see <i>OTS400 Operating Instructions</i> (no. 8008869, English edition). • Check in OTC400 with the "CLV-Setup" program: choose the DEVICE CONFIGURATION tab, click the READING PARAMETERS tab, OPERATING MODE section: one of the two modes for master/slave selected?
<p>2. Trigger mode in the CLV490: OTS trigger</p> <p>Reading mode "Tracking":</p> <p>CLV490 not triggered by the OTC400:</p> <ul style="list-style-type: none"> – the "Sensor" LED does not light up – the red scan line does not appear 	<ul style="list-style-type: none"> • Incorrect reading pulse source parameterized in the CLV490. • CAN interface incorrectly parameterized in the CLV490. • Sensor for beginning of object (at the beginning of the reading field) incorrectly connected to OTC400 or switching input incorrectly parameterized. • Incorrect operation mode selected in the OTC400. 	<ul style="list-style-type: none"> • In the "CLV-Setup" program: choose the DEVICE CONFIGURATION tab, READING TRIGGER SOURCE section: "OTS trigger" mode selected? • Check: CAN INTERFACE tab, CAN INTERFACE FUNCTION section: "OTS Slave" as well as "data transfer rate" selected in accordance to OTC400? • Check connection and parameterization of switching inputs, see <i>OTS400 Operating Instructions</i> (no. 8008869, English edition). • Check in OTC400 with the "CLV-Setup" program: choose the DEVICE CONFIGURATION tab, click the READING TRIGGER PARAMETERS button, OPERATING MODE section: "Increment controlled (Tracking)" selected?

Table 8-7: Troubleshooting: reading trigger errors in Reading mode (CLV490 integrated in OTS400 Omni Tracking System)

8.5.3 Malfunctions in Reading mode: result output errors

- Check whether the "Device Ready" LED lights up.
If the LED does not light, see [Table 8-5, Page 8-9](#).

CLV490 in stand-alone configuration

Here: number of bar codes to be read = 1

Malfunction	Possible cause	Remedy
<p>1. The "Read Result" LED (default setting: Good Read) does not light up at the end of the reading pulse.</p> <ul style="list-style-type: none"> – The "Result 2" switching output (default setting: Good Read) is not outputting a pulse – The CLV490 outputs status ST=2 in the reading result on the host interface (outputting of ST disabled by default) – The CLV490 outputs the message "no code" in the reading result of the auxiliary interface 	<ul style="list-style-type: none"> • Read not successful, since there was no bar code in the reading field during the reading pulse. • Scan line positioned incorrectly. • Bar code presented at incorrect reading distance. • The presented bar code's module width cannot be read by the CLV490 type being used. <p><i>Reading range (bar code evaluation range):</i></p> <ul style="list-style-type: none"> • Evaluation range of the scan line is limited unfavourable (reading angle values). – or – • Parametrized rectangular reading area does not match the conditions in situ. • Position of the CLV490 referred to the reading space not or incorrectly parameterized. <p><i>Focus control:</i></p> <ul style="list-style-type: none"> • Focus control not activated. 	<ul style="list-style-type: none"> • Synchronize read with presence of an object in reading field. See Chapter 8.5.2 Malfunctions in Reading mode: reading trigger errors, Page 8-10. • Align CLV490. Is bar code at center of scan line? Check the reading quality with the "CLV-Setup" program: choose PER-CEN-TAGE EVALUATION. See Chapter 6.5.2 Percentage evaluation, Page 6-41. • Check whether reading distance of bar code is in the specified reading range? • Present a bar code with an acceptable module width. See Chapter 9 Technical data, Page 9-1. • In the "CLV-Setup" program: choose the READING CONFIGURATION tab, click the AUTOFOCUS PARAMETERS respectively DISTANCE CONFIGURATION button. Are the min. and max. reading angle values correct? Check with SHOW RA-LIMITS. See Chapter 6.5.5 Show RA-limits, Page 6-46. • In the "CLV-Setup" program: choose the READING CONFIGURATION tab, READING AREA section, READING AREA option, click the READING SPACE PARAMETERS button: are the values for reading space correct? • In the "CLV-Setup" program: choose the DEVICE CONFIGURATION tab, click the SCANNER POSITION PARAMETERS button: are the values correct? • In the "CLV-Setup" program: choose the READING CONFIGURATION tab, FOCUS CONTROL section: "Autofocus" or "Inputs/serial" for event-controlled focus position switchover selected? (for oscillating mirror also "Oscillating Mirror Extrema")

Table 8-8: Troubleshooting: result output errors in Reading mode (CLV490 in stand-alone configuration)

Malfunction	Possible cause	Remedy
<p>1. The "Read Result" LED (default setting: Good Read) does not light up at the end of the reading pulse:</p> <p>– <i>continued</i> –</p>	<p><i>Autofocus:</i></p> <ul style="list-style-type: none"> • An obstacle in the reading area is closer to CLV490 than the object carrying the bar code(s). The CLV490 focuses on the obstacle and not on the object (autofocus mode incorrectly parameterized). • Autofocus parameters incorrectly parameterized. <p><i>Event-controlled focus control:</i></p> <ul style="list-style-type: none"> • Wrong focus position in Distance Configuration choosen. • CLV490 does not switch over the focus position: trigger source incorrectly parameterized. 	<ul style="list-style-type: none"> • In the "CLV-Setup" program: choose the READING CONFIGURATION tab, AUTOFOCUS section: "Differential background" selected? • In the "CLV-Setup" program: choose the READING CONFIGURATION tab, AUTOFOCUS section: click the AUTOFOCUS PARAMETERS button, click the AUTOFOCUS LIMITS PARAMETERS button: are the values for limitations and/or the autofocus space correct? Is the autofocus range within the limits of the parameterized reading range? • In the "CLV-Setup" program: choose the READING CONFIGURATION tab, click the DISTANCE CONFIGURATION button. Does the focus position match the distance of the object? • In the "CLV-Setup" program: choose the READING CONFIGURATION tab, FOCUS CONTROL section: <ul style="list-style-type: none"> a) Trigger source "Inputs/Serial": Check functional assignment of "IN 3" and "IN 4" and connection of the sensors. See Fig 5-6, Page 5-23 b) Trigger source: "Serial interface": Check the data connection to the host. Use the "CLV-Setup" program to check the host command strings: choose AUXILIARY INTERFACE tab. Choose MONITOR HOST INTERFACE function. See Chapter 6.5.10 Monitor Host Interface, Page 6-54. Download temporarily to CLV490! c) Trigger source: Timer: Check switchover time referred to the start of reading interval d) Line scanner with oscillating mirror: Optional "Oscillating Mirror Extrema" selected?

Table 8-8: Troubleshooting: result output errors in Reading mode (CLV490 in stand-alone configuration) (contd.)

Malfunction	Possible cause	Remedy
<p>1. The "Read Result" LED default setting: Good Read) does not light up at the end of the reading pulse:</p> <p>– continued –</p>	<ul style="list-style-type: none"> • The bar code is tilted excessively with respect to the scan line. • The reading angles at which the bar code appears to the CLV490 are too large. • Bar code in total reflection zone • Evaluation criteria for bar code incorrect. • Bar code quality inadequate. 	<ul style="list-style-type: none"> • In the "CLV-Setup" program: choose the CODE CONFIGURATION tab, DECODER section: choose SMART decoder. Download all changes to CLV490! • In the "CLV-Setup" program: choose the CODE CONFIGURATION tab, DECODER section: choose Standard decoder. Download temporarily to CLV490! Start PERCENTAGE EVALUATION, choose DISTANCE CONFIGURATION. Monitor reading quality (reading quality > 70 %!). If necessary, realign CLV490 and/or reconfigure distance configuration. If ok, choose SMART DECODER. Download to CLV490. • Optimize CLV490 alignment (scan line should strike the bar code at a skew of approx. 15°). Use the "CLV-Setup" program to check the quality of the read. Start PERCENTAGE EVALUATION. See Chapter 6.5.2 Percentage evaluation, Page 6-41 • In "CLV-Setup" program: choose the CODE CONFIGURATION tab, SYMBOLOGIES section. Enable all code types (except Pharmacode), set code lengths to FREE. Download temporarily to CLV490! Start PERCENTAGE EVALUATION. Code type and length are displayed in the reading result. Enable recorded code type in the CODES section and disable all other types. Enter the code length under FIXED on the code type tab. Download to CLV490! • Check: sufficient blank zones present? Print contrast adequate? Specified print tolerances exceeded? In the "CLV-Setup" program: choose READING CONFIGURATION tab, READING PARAMETERS section, START/STOP RATIO: is Auto selected? Perform read with reference code.
<p>2. The CLV490 is not transferring any reading results to the host</p>	<ul style="list-style-type: none"> • Reading pulse is not functioning correctly. • Wiring fault in data connection. • Voltage level incorrect. • Host interface in CLV490 parameterized incorrectly. 	<ul style="list-style-type: none"> • See Chapter 8.5.2 Malfunctions in Reading mode: reading trigger errors, Page 8-10 • Check wiring as shown in Fig. 5-3, Page 5-20 • Measure voltages • In "CLV-Setup" program: choose HOST INTERFACE tab, DATA FORMAT section. Are the interface type (hardware) and data format correct? Check settings in INTERFACE PROTOCOL section.

Table 8-8: Troubleshooting: result output errors in Reading mode (CLV490 in stand-alone configuration) (contd.)

CLV490 Bar Code Scanner

Malfunction	Possible cause	Remedy
3. The data content of the bar code output by the CLV490 is incorrect or incomplete.	<ul style="list-style-type: none"> The data format on the host interface is parameterized incorrectly in the CLV490. The CLV490 suppresses the last character in the bar code. 	<ul style="list-style-type: none"> In the "CLV-Setup" program: choose the HOST INTERFACE tab, DATA FORMAT section. Are the values correct? In the "CLV-Setup" program: choose the CODE CONFIGURATION tab, SYMBOLOGIES section. Click the EDIT button of the relevant code. Is the TRANSMIT CHECK DIGIT checkbox activated? Change if necessary. Download to CLV490!
4. The CLV490 transfers the status ST=3 to the host in the reading result (outputting of ST disabled by default)	The CLV490 has diagnosed a device error in the self-test.	Switch the CLV490 off and on again. Does the "Device Ready" LED light up? If not, contact the SICK Service department.

Table 8-8: Troubleshooting: result output errors in Reading mode (CLV490 in stand-alone configuration) (contd.)

Additional for CLV490 integrated in OTS400 Omni Tracking System

Malfunction	Possible cause	Remedy
1. OTS Reading mode: "Start/stop" <ul style="list-style-type: none"> The "Read Result" LED on CLV490 (default setting: Good Read) does not light up at the end of reading interval 	If the CLV490 uses object information from OTC400 or other CLV490: CLV490 is not receiving any object information.	In the "CLV-Setup" program: choose READING CONFIGURATION tab, FOCUS CONTROL section: "OTS height information" selected?
2. OTS Reading mode: "Tracking" <ul style="list-style-type: none"> The "Read Result" LED on CLV490 (default setting: Good Read) does not light up during reading process 	<ul style="list-style-type: none"> CLV490 is not receiving any increment information from OTC400. Release points incorrectly parameterized in the CLV490. 	<ul style="list-style-type: none"> Check connection and parameterization of incremental encoder on the OTC400, see <i>OTS400 Operating Instructions</i> (no. 8008869, English edition). In the "CLV-Setup" program: choose the DEVICE CONFIGURATION tab, click the TRACKING PARAMETERS button: are the values correct? Is the object release point of CLV490 within the limits of the object release point of OTC400?
3. OTS Reading mode: "Tracking " <ul style="list-style-type: none"> OTS400 not sending any reading results to the host 	<ul style="list-style-type: none"> If an incremental encoder is connected: the sensor is transferring an incorrect conveyor speed to the arrangement. As a result, the OTC400 cannot correctly assign bar codes to the objects. If an internal increment pulse is used in the arrangement: the pulse does not match the actual conveyor speed. 	<ul style="list-style-type: none"> Check contact between the incremental encoder and conveyor belt If objects are read on a section between belts, checks whether the conveyor speed of the two belts is different Adapt the internal increment pulse to the actual conveyor speed or connect an external incremental encoder to OTC 400 if the conveyor speed is not constant (parameterize switching input accordingly)

Table 8-9: Troubleshooting: result output errors in Reading mode (CLV490 integrated in the OTS400 Omni Tracking System)

8.5.4 Malfunctions in Reading mode: errors in the result status output

- Check whether the "Device Ready" LED lights up.
If the LED does not light, see [Table 8-5, Page 8-9](#).

Malfunction	Possible cause	Remedy
The switching outputs – "Result 1" (default setting: Device Ready) – "Result 2" (default setting: Good Read) – "Result 3" (default setting: No Read) – "Result 4" (default setting: Match 1) are not outputting any pulses.	<ul style="list-style-type: none"> • The event associated with the assigned function for outputting the result status of the read does not occur in the reading operation. • Incorrect switching mode parameterized in the CLV490. 	<ul style="list-style-type: none"> • Not applicable. • In the "CLV-Setup" program: choose the DEVICE CONFIGURATION tab. Click the RESULT OUTPUT PARAMETERS button. Are the outputs set to "No Invert Output"? Change if necessary. Download to CLV490!

Table 8-10: Troubleshooting: errors in the result status output in Reading mode

8.5.5 Malfunctions in Reading mode: oscillating mirror errors

- Check whether the "Device Ready" LED lights up.
If the LED does not light, see [Table 8-5, Page 8-9](#).

Malfunction	Possible cause	Remedy
1. The oscillating mirror does not move.	Incorrect operating mode set in the CLV490.	In the "CLV-Setup" program: choose the OSCILLATING MIRROR tab, OSCILLATING MIRROR section. Is OSCILLATING WITH FIX AMPLITUDE or OSCILLATING WITH VARIABLE AMPLITUDE selected?
2. The oscillating mirror oscillates with maximum deflection (40 CW), even though a variable amplitude, e. g. 10 CW, is set in the distance configuration 1.	<ul style="list-style-type: none"> • OSCILLATING WITH FIX AMPLITUDE set in the CLV490 by mistake. • The oscillating amplitude is parameterized in the wrong distance configuration (here: no. 2). • The distance configuration (focus position) was not changed. 	<ul style="list-style-type: none"> • From the OSCILLATING MIRROR tab, choose OSCILLATING WITH VARIABLE AMPLITUDE. Download to the CLV490! • In the "CLV-Setup" program: choose the READING CONFIGURATION tab, click the DISTANCE CONFIGURATION button. Is the amplitude value set in the correct distance configuration (here: no. 1)? • In the "CLV-Setup" program: choose the DEVICE CONFIGURATION tab. Assignment of Inputs for "IN 3" and "IN 4": is focus control selected? Connect sensors to the switching inputs. Check sensor wiring (see Fig. 5-6, Page 5-23). Measure output signal at sensor
3. One-Shot: The One-Shot function cannot be triggered (sensor correctly connected to the "IN 3" or "IN 4" switching input).	<ul style="list-style-type: none"> • Trigger source incorrectly parameterized • "IN 3" or "IN 4" switching input has not been assigned this function. 	<ul style="list-style-type: none"> • In the "CLV-Setup" program: choose the OSCILLATING MIRROR tab. Is "one-shot" selected? • Choose DEVICE CONFIGURATION tab. ASSIGNMENT FOR INPUTS section: "IN 3" or "IN 4": is trigger "One-Shot" selected?

Table 8-11: Troubleshooting: oscillating mirror errors in Reading mode

8.6 SICK Support

If a system error occurs repeatedly ("CLVSYS-Failure: xxx", xxx= 000 ... 215) or if you cannot correct an error using the above measures, the CLV490 may be defective. The CLV490 cannot be repaired by the user, meaning that it is not possible to re-establish functions after a failure. However, the CLV490 can be rapidly replaced by the user. See [Chapter 10.12 Replacing a CLV490 \(copying the parameter set\), Page 10-73](#).

- Please contact our local SICK office or subsidiary if an error occurs which cannot be eliminated:
 - The telephone numbers and email addresses are listed on the *back page* of this manual.
For postal addresses see also **www.sick.com**.
- Do not send the device to the SICK service without first contacting us.

9 Technical data

9.1 Data sheet CLV490-0010/-2010/-6010 bar code scanner

Type	CLV490-0010 (Standard density)	CLV490-2010 (High density)	CLV490-6010 (Low density)
Design	line scanner (standard device), without heater		
Reading window	front		
Laser diode (wave length)	red light ($\lambda = 650$ nm)		
MTFB of laser diode	20,000 h		
Laser class	Class 2 pursuant to EN/IEC 60825-1 (for publication date, see the warning sign on the device), shutoff of laser diode after 10 min ¹⁾		
Focus Control	Autofocus, alternatively event-controlled focus control		
No. of distance configurations (DC)	max. 8		
Focus adjustment time	≤ 20 ms (typically)		
Focus trigger source	"IN 0" to "IN 4" switching inputs/data interface/timer		
Useful aperture angle	max. 60° (front-end reading window)		
Scanning/decoding frequency	600 to 1,200 Hz		
Resolution (typically)	0.25 to 1.0 mm (9.8 to 39.4 mil)	0.17 to 0.4 mm (6.7 to 15.7 mil)	0.35 to 1.2 mm (13.8 to 47.3 mil)
Reading ranges	see Page 10-3	see Page 10-16	see Page 10-27
Bar code print contrast (PCS)	≥ 60 %		
Ambient light compatibility	2,000 lx (on bar code)		
No. of bar codes per scan	1 to 12 (standard decoder), 1 to 5 (SMART decoder)		
No. of bar codes per reading interval ²⁾	1 to 50 (autodiscriminating)		
Bar code types	Code 39, Code 128, Code 93, Codabar, EAN, EAN 128, UPC, 2/5 Interleaved		
Bar code length	max. 50 characters (max. 600 characters across all bar codes per reading interval)		
Print ratio	2:1 to 3:1		
No. of multiple reads	1 to 99		
Optical indicators	4 x LEDs (status indicators)		
Reading pulse	"Sensor" switching input (Option: additionally "IN 4")/Free-running/Serial interface/Object Polling/OTS		
"Host" data interface	RS 232 or RS 422/485, variable data output format		
Data transmission rate	300 to 57,600 bd		
Protocols	SICK Standard and 3964(R)		
Physical configurations	Stand-alone		
"CAN" data interface	CANopen protocol, CAN Scanner Network		
Data transmission rate	20 kbit/s to 1 Mbit/s		
"Auxiliary" data interface	RS 232, 9,600 bd, 8 data bits, no parity, 1 stop bit, fixed output format		
Switching inputs	6 (Sensor, "IN 0" to "IN 4") <ul style="list-style-type: none"> – optodecoupled, $V_{\text{imax}} = +30$ V, non-interchangeable, can be connected to PNP outputs – "Sensor" (reading pulse): max. internal delay 30 ms, reduced max. 2 to 6 ms – "IN 0" to "IN 4": focus position switching, IN 3 and IN 4: selectable function, max. internal delay 30 ms 		
Switching outputs	4 ("Result 1" to "Result 4") <ul style="list-style-type: none"> – PNP, short-circuit-proof, variable pulse duration (static; resolution 10 to 990 ms or 100 to 9,900 ms) – Variable output function for result status 		
1) Default setting, in Reading mode with the "Switching input sensor" and "Serial interface pulse" types. 2) Reading interval: time window generated internally for evaluating the code.			

Table 9-1: Technical specifications of the CLV490-0010/-2010/-6010

Type	CLV490-0010 (Standard density)	CLV490-2010 (High density)	CLV490-6010 (Low density)
Electrical connections	1 x 15-pin D Sub HD plug, 1 x 15-pin D Sub HD socket		
Operating voltage/power consumption	18 to 30 V DC/ typically 11 W, max. 16 W SELV respectively PELV pursuant to IEC 60364-4-41 (2005)		
Housing	Aluminium die-cast, does not represent a problem in paint shops		
Electrical safety	pursuant to EN 61010-1 (2001-03)		
Protection class	III, pursuant to EN 61140 (2002-03)		
Enclosure rating	IP 65 ³⁾ pursuant to EN 60529 (1991-10); A1: 2002-02)		
EMC tested	pursuant to EN 61000-6-2 (2001-10), EN 61000-6-3 (2001-10), EN 61000-6-3/A11 (2004-07)		
Vibration/shock tested	pursuant to EN 60068-2-6/to EN 60068-2-27		
Weight	approx. 1.5 kg (approx. 3.3 lb)		
Ambient operating/storage temperature	0 to +40 °C/−20 to +70 °C (+32 to +104 °F/−4 to +158 °F)		
Max. rel. humidity	90 %, non condensing		
Color	SICK blue (RAL 5012)		
3) With plug cover or plug cover with parameter memory			

Table 9-1: Technical specifications of the CLV490-0010/-2010/-6010 (contd.)

9.2 Data sheet CLV490-1010/-3010/-7010 bar code scanner

Technical data as CLV490-0010/-2010/-6010 with the following exceptions:

Type	CLV490-1010 (Standard density)	CLV490-3010 (High density)	CLV490-7010 (Low density)
Design	line scanner with oscillating mirror		
Reading window	side		
Angle of emergence	105° (center position CW = 50)		
Trigger source for focus control	also: oscillating mirror reversal points		
Useful aperture angle	max. 50°		
Oscillating mirror functions	permanent (variable position)/oscillating (amplitude per DC variable or fixed)/One-Shot ¹⁾		
Oscillating frequency	0.2 to 4 Hz		
Max. angle of deflection	max. ±20° (±40 CW), (set with software)		
Reading ranges	see Page 10-9	see Page 10-21	see Page 10-31
Deflection ranges	see Page 10-15	see Page 10-26	see Page 10-33
Operating voltage/power consumption	18 to 30 V DC/ typically 13 W, max. 18 W SELV respectively PELV pursuant to IEC 60364-4-41 (2005)		
Weight	approx. 2.2 kg (approx. 4.84 lb)		
¹⁾ One-Shot: one-off oscillating movement per reading pulse (start position and velocity can be selected for forward and return phase)			

Table 9-2: Technical specifications of the CLV490-1010/-3010/-7010

9.3 Data sheet CLV490-0011 /-2011/-6011 bar code scanner

Technical data as CLV490-0010/-2010/-6010 with the following exceptions:

Type	CLV490-0011 (Standard density)	CLV490-2011 (High density)	CLV490-6011 (Low density)
Design	line scanner with heater		
Switching on function/temperature graph	see Chapter 10.4 Optional heating, Page 10-40		
Power-on delay	35 to 40 min (at 24 V DC and min. ambient operating temperature –35 °C (–31 °F))		
Operating voltage/power consumption	24 V DC +20 %/–10 %/ typically 75 W, max. 90 W SELV respectively PELV pursuant to IEC 60364-4-41 (2005)		
Required cross-section	min. 0.75 mm ² (20 AWG) (for power supply)		
Weight	approx. 1.5 kg (approx. 3.3 lb)		
Ambient operating/storage temperature	–35 to +35 °C/–20 to +70 °C (–31 to +95 °F/–4 to +158 °F)		

Table 9-3: Technical specifications of the CLV490-0011/-2011/-6011

9.4 Data sheet CLV490-1011/-3011/-7011 bar code scanner

Technical data as CLV490-1010/-2010/-6010 with the following exceptions:

Type	CLV490-1011 (Standard density)	CLV490-3011 (High density)	CLV490-7011 (Low density)
Design	line scanner with oscillating mirror and heater		
Switching on function/temperature graph	see Chapter 10.4 Optional heating, Page 10-40		
Power-on delay	35 to 40 min (at 24 V DC and min. ambient operating temperature –35 °C (–31 °F))		
Operating voltage	24 V DC +20 %/–10 %/ typically 75 W, max. 100 W SELV respectively PELV pursuant to IEC 60364-4-41 (2005)		
Required cross-section	min. 0.75 mm ² (20 AWG) (for power supply)		
Weight	approx. 2.2 kg (approx. 4.84 lb)		
Ambient operating/storage temperature	–35 to +35 °C/–20 to +70 °C (–31 to +95 °F/–4 to +158 °F)		

Table 9-4: Technical specifications of the CLV490-1011/-3011/-7011

9.5 Dimensioned drawings – CLV490

9.5.1 Line scanner (standard device) without /with heater

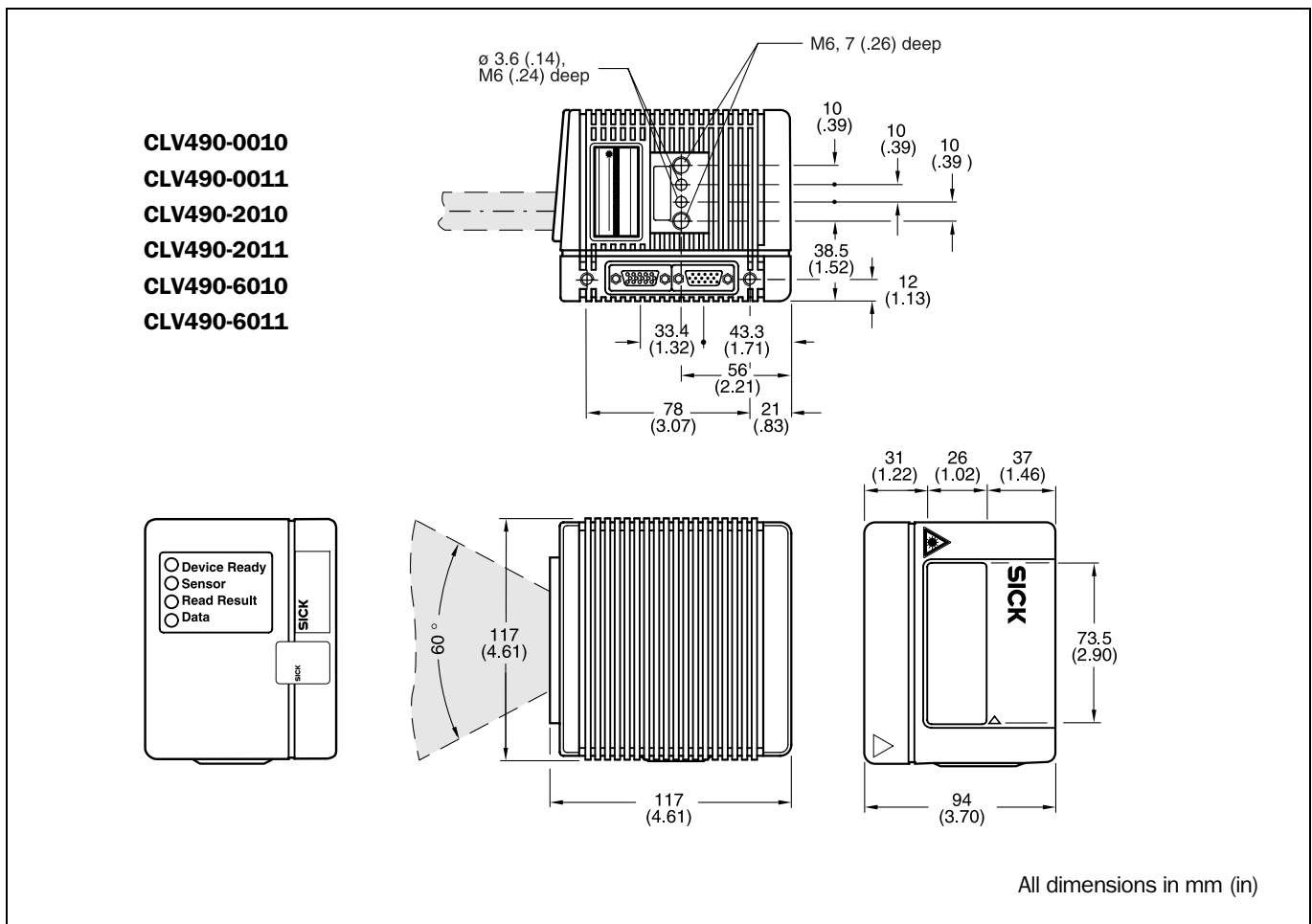

Fig. 9-1: Dimensions of the CLV490 line scanner, front reading window

9.5.2 Line scanner with oscillating mirror (without/with heater)

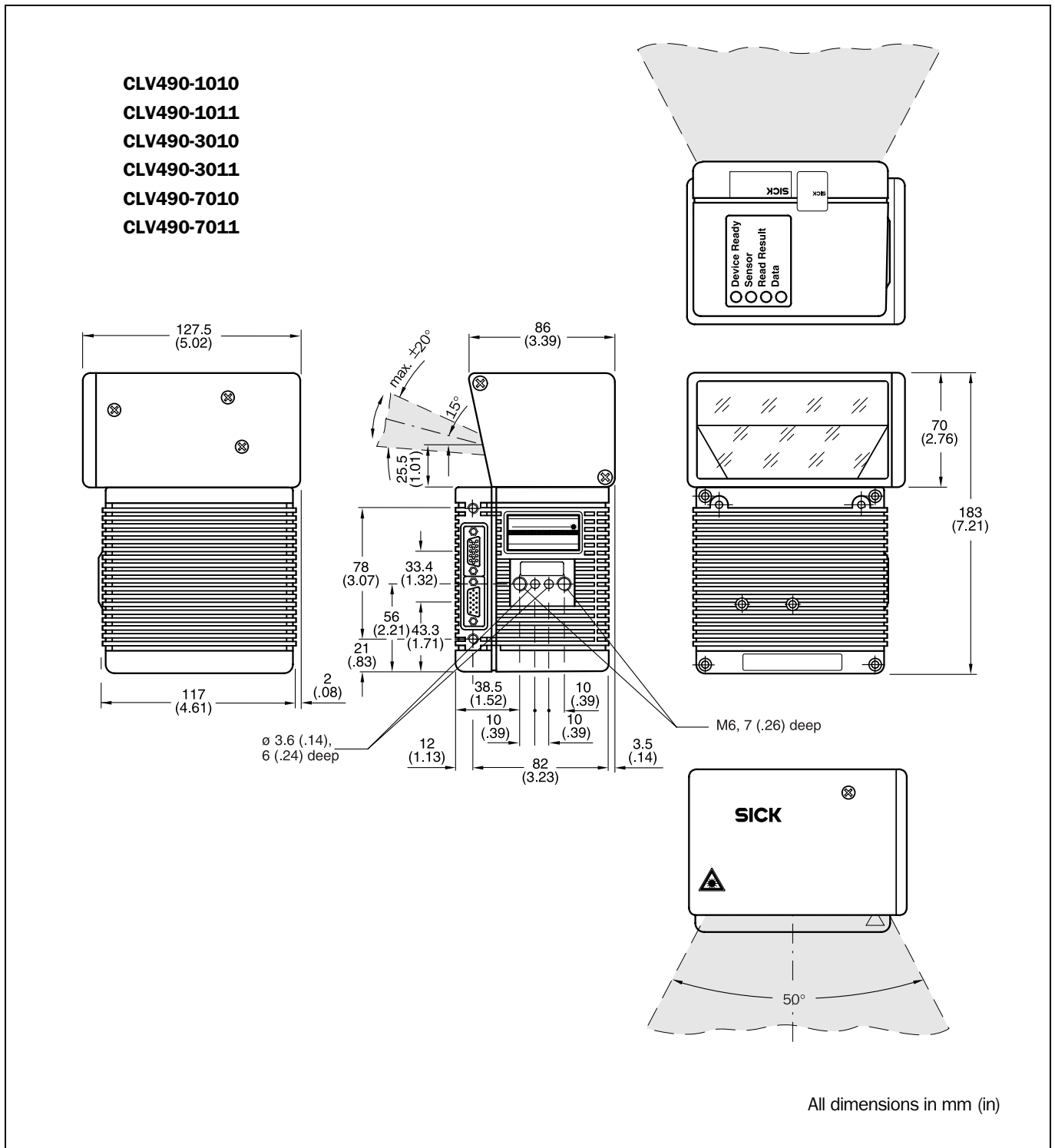

Fig. 9-2: Dimensions of the CLV490: line scanner with oscillating mirror, side reading window

Notes:

10 Appendix

10.1 Overview

The appendix contains the following additional information:

- Specification diagrams
 - Line scanner (all variants)
 - Line scanner with oscillating mirror (all variants)
- Installation and operating instructions for the external parameter memory
- Optional heating (temperature graph/ switching on function)
- System messages
- Installation and operating instructions for the PC-based "CLV-Setup" program
- Configuring a CLV490 using command strings
- Parameter value calculations for configuring the CLV490
- Tables
- Discussion of a parameterization example
- Special applications and procedures
- Instructions for replacing a CLV490 (copying the parameter set)
- Ordering information
- Dimensioned drawings of the accessories
- Notes on supplementary documentation
- Glossary
- Copy of the EC-Declaration of Conformity
- Index
- Scannable sample bar codes

10.2 Specification diagrams

10.2.1 Reading conditions for all diagrams

Test code	Code 128
Print ratio	> 90 %
Tilt	$\pm 45^\circ$
Ambient light	< 2,000 lx
Good Read rate	> 75 %

Table 10-1: Reading conditions for specification diagrams

Note The min. and max. reading distances are measured radially by the CLV490.

10.2.2 Overview of diagrams

Line scanner

CLV490-Type	Resolution	Scanning method	Diagram	Page
CLV490-0010/-0011	Standard density	Line scanner	Reading field height/resolution as a function of reading distance	10-3
CLV490-0010/-0011	Standard density	Line scanner	Min. and max. reading distance (DOF) for 0.35 mm/40°	10-4
CLV490-0010/-0011	Standard density	Line scanner	Min. and max. reading distance (DOF) for 0.35 mm/56°	10-5
CLV490-0010/-0011	Standard density	Line scanner	Min. and max. reading distance (DOF) for 0.50 mm/40°	10-6
CLV490-0010/-0011	Standard density	Line scanner	Min. and max. reading distance (DOF) for 0.50 mm/56°	10-7
CLV490-0010/-0011	Standard density	Line scanner	Characteristics field scanning frequency	10-8
CLV490-2010/-2011	High density	Line scanner	Reading field height/resolution as a function of reading distance	10-16
CLV490-2010/-2011	High density	Line scanner	Min. and max. reading distance (DOF) for 0.25 mm/40°	10-17
CLV490-2010/-2011	High density	Line scanner	Min. and max. reading distance (DOF) for 0.35 mm/40°	10-18
CLV490-2010/-2011	High density	Line scanner	Min. and max. reading distance (DOF) for 0.35 mm/56°	10-19
CLV490-2010/-2011	High density	Line scanner	Characteristics field scanning frequency	10-20
CLV490-6010/-6011	Low density	Line scanner	Reading field height/Tilt as a function of reading distance for 0.5 mm	10-27
CLV490-6010/-6011	Low density	Line scanner	Min. and max. reading distance (DOF) for 0.5 mm/40°	10-28
CLV490-6010/-6011	Low density	Line scanner	Min. and max. reading distance (DOF) for 0.5 mm/60°	10-29
CLV490-6010/-6011	Low density	Line scanner	Characteristics field scanning frequency	10-30

Table 10-2: Overview of specification diagrams for the line scanner

Line scanner with oscillating mirror

CLV490-Type	Resolution	Scanning method	Diagram	Page
CLV490-1010/-1011	Standard density	L.s. with osci. mirror	Reading field height/resolution as a function of reading distance	10-9
CLV490-1010/-1011	Standard density	L.s. with osci. mirror	Min. and max. reading distance (DOF) for 0.35 mm/40°	10-10
CLV490-1010/-1011	Standard density	L.s. with osci. mirror	Min. and max. reading distance (DOF) for 0.35 mm/50°	10-11
CLV490-1010/-1011	Standard density	L.s. with osci. mirror	Min. and max. reading distance (DOF) for 0.50 mm/40°	10-12
CLV490-1010/-1011	Standard density	L.s. with osci. mirror	Min. and max. reading distance (DOF) for 0.50 mm/50°	10-13
CLV490-1010/-1011	Standard density	L.s. with osci. mirror	Characteristics field scanning frequency	10-14
CLV490-1010/-1011	Standard density	L.s. with osci. mirror	Deflection range	10-15
CLV490-3010/-3011	High density	L.s. with osci. mirror	Reading field height/resolution as a function of reading distance	10-21
CLV490-3010/-3011	High density	L.s. with osci. mirror	Min. and max. reading distance (DOF) for 0.25 mm/40°	10-22
CLV490-3010/-3011	High density	L.s. with osci. mirror	Min. and max. reading distance (DOF) for 0.35 mm/40°	10-23
CLV490-3010/-3011	High density	L.s. with osci. mirror	Min. and max. reading distance (DOF) for 0.35 mm/50°	10-24
CLV490-3010/-3011	High density	L.s. with osci. mirror	Characteristics field scanning frequency	10-25
CLV490-3010/-3011	High density	L.s. with osci. mirror	Deflection range	10-26
CLV490-7010/-7011	Low density	L.s. with osci. mirror	Reading field height/Tilt as a function of reading distance for 0.5 mm	10-31
CLV490-7010/-7011	Low density	L.s. with osci. mirror	Min. and max. reading distance (DOF) for 0.5 mm/40°	10-28
CLV490-7010/-7011	Low density	L.s. with osci. mirror	Min. and max. reading distance (DOF) for 0.5 mm/50°	10-29
CLV490-7010/-7011	Low density	L.s. with osci. mirror	Characteristics field scanning frequency	10-32
CLV490-7010/-7011	Low density	L.s. with osci. mirror	Deflection range	10-33

Table 10-3: Overview of specification diagrams for the line scanner with oscillating mirror

10.2.3 Standard density: Reading performance data of line scanner

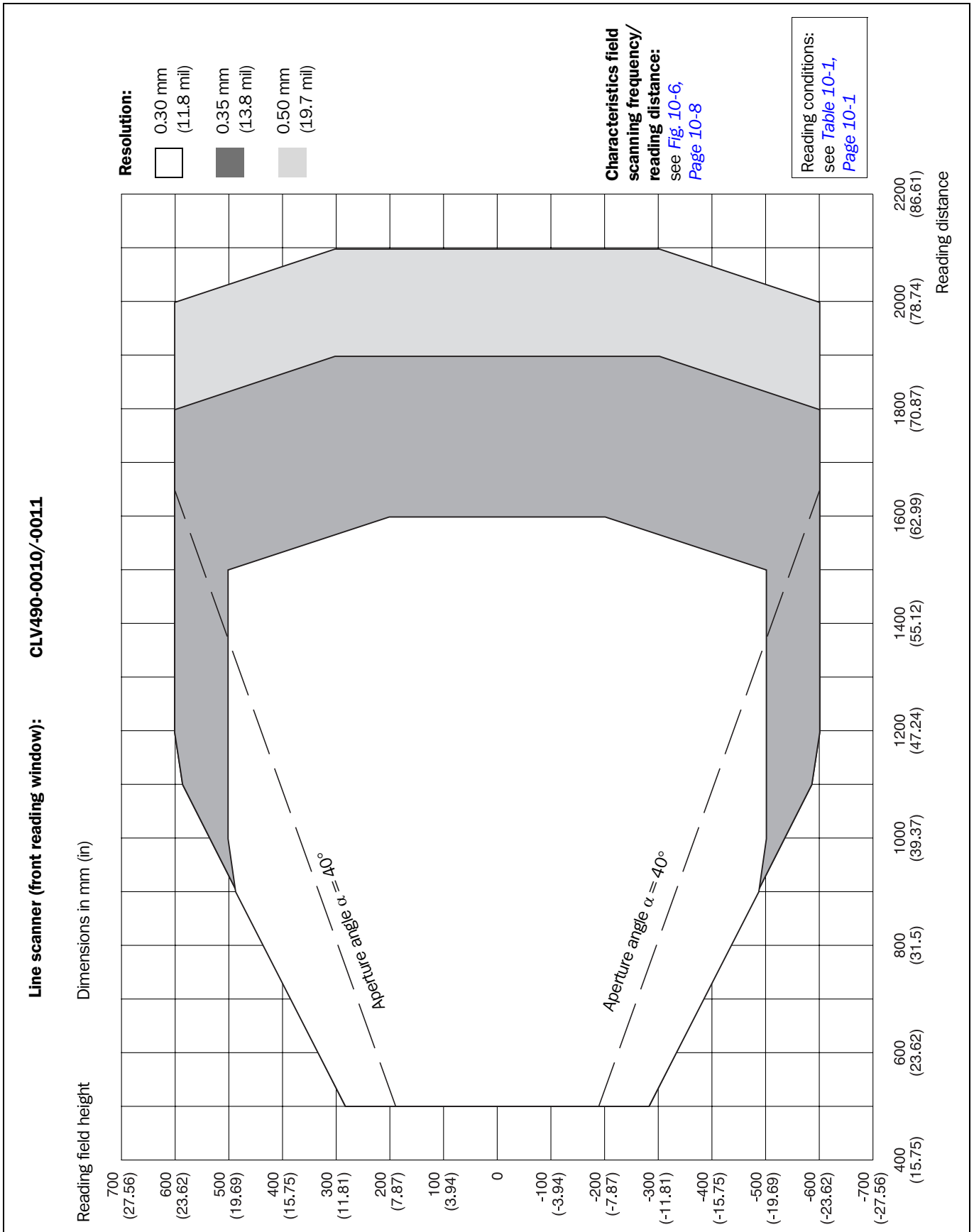

Fig. 10-1: CLV490-0010/-0011 (Standard density): Reading field height as a function of the reading distance and resolution

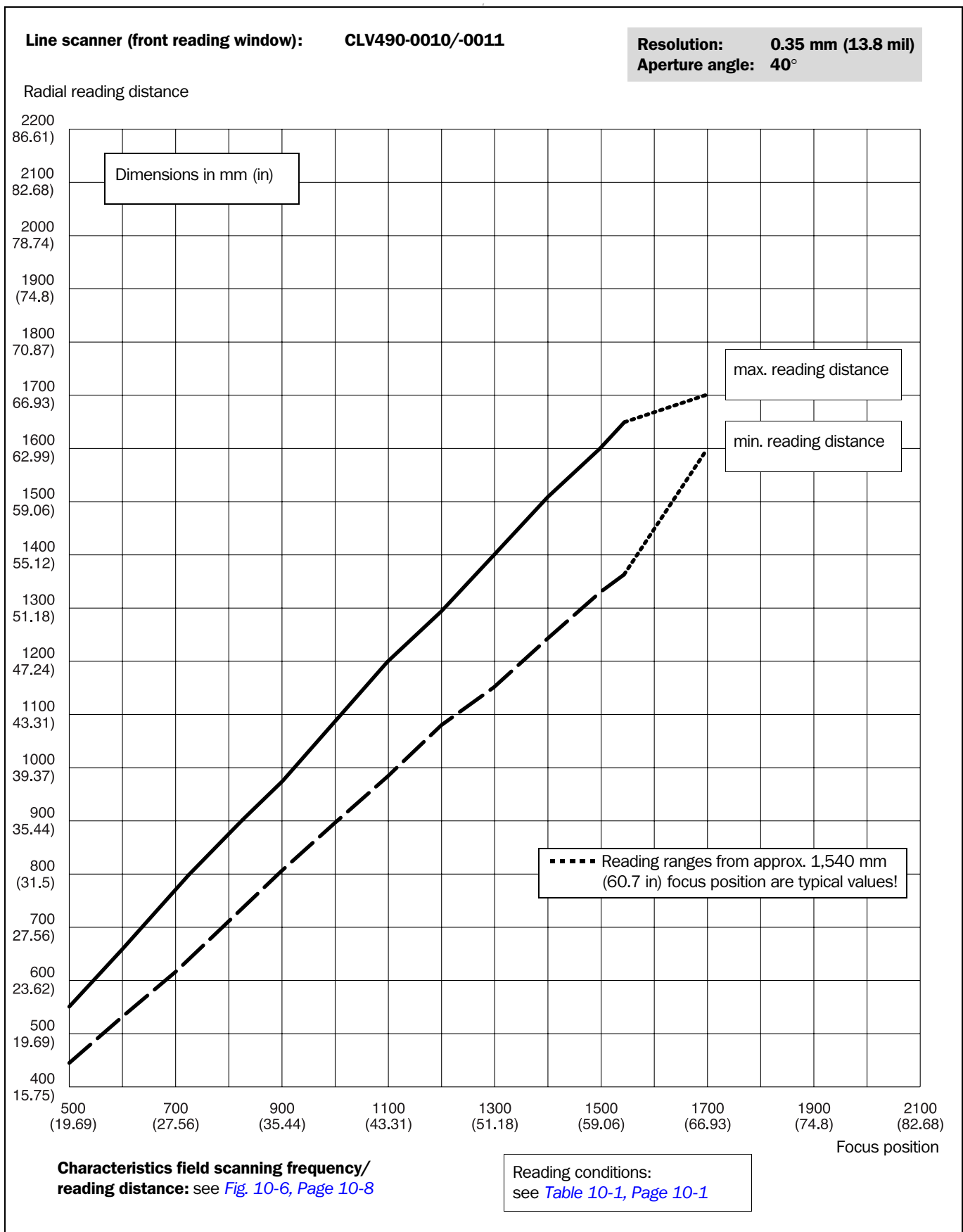

Fig. 10-2: CLV490-0010/-0011 (Standard density): Min. and Max. reading distance (measured radially) as a function of the focus position at a resolution of 0.35 mm (13.8 mil) and an aperture angle of $\alpha = 40^\circ$

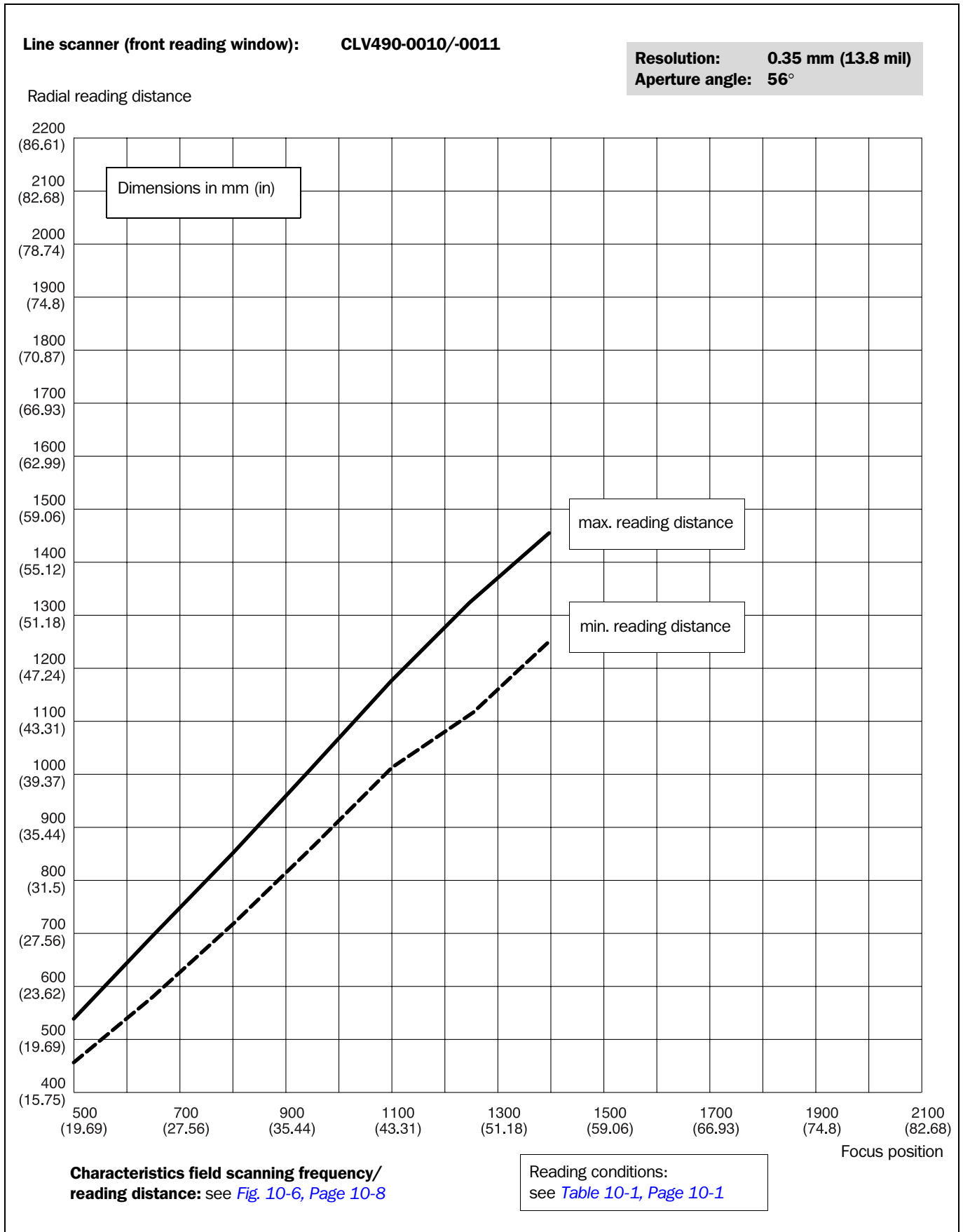

Fig. 10-3: CLV490-0010/-0011 (Standard density): Min. and Max. reading distance (measured radially) as a function of the focus position at a resolution of 0.35 mm (13.8 mil) and an aperture angle of $\alpha = 56^\circ$

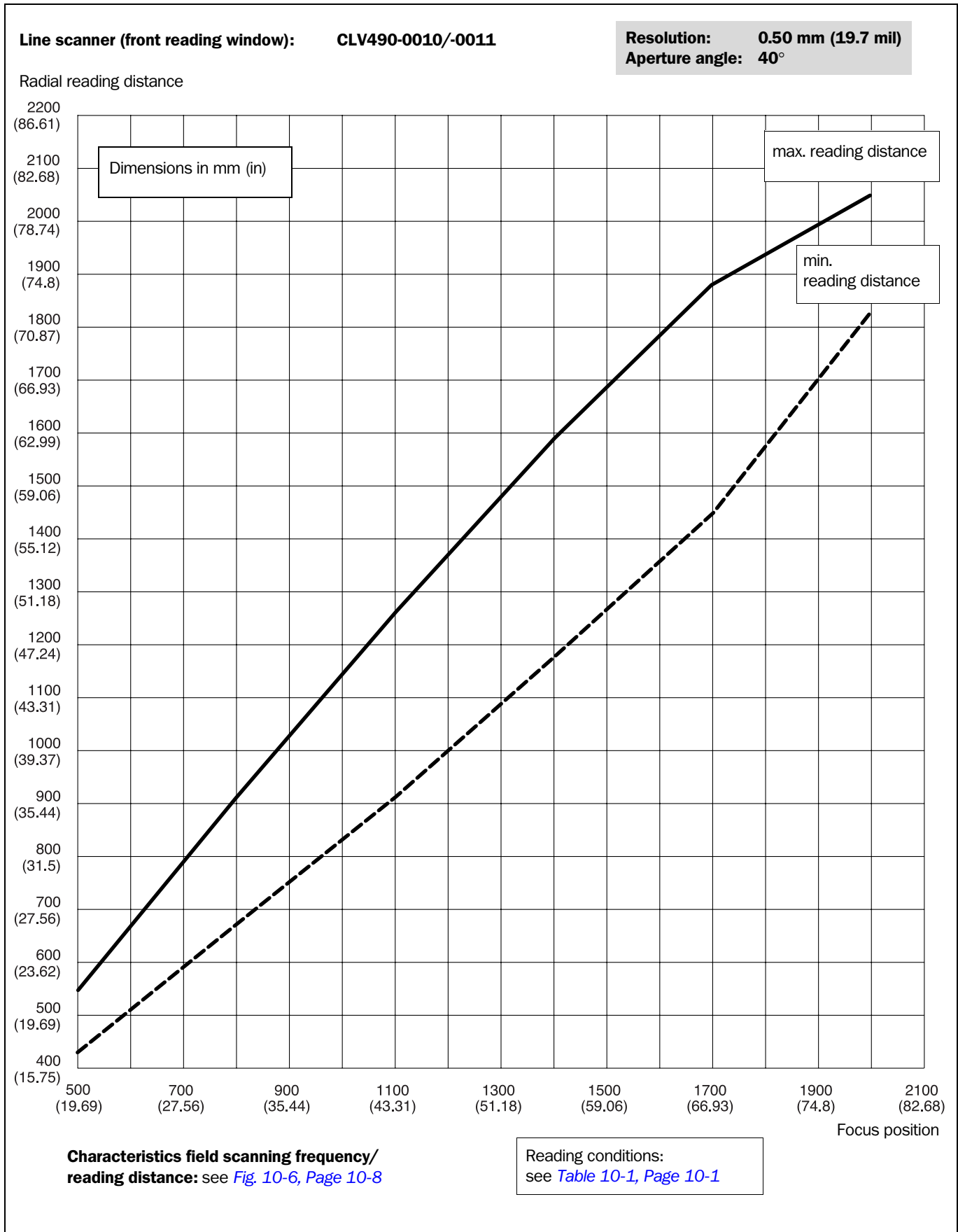

Fig. 10-4: CLV490-0010/-0011 (Standard density): Min. and Max. reading distance (measured radially) as a function of the focus position at a resolution of 0.50 mm (19.7 mil) and an aperture angle of $\alpha = 40^\circ$

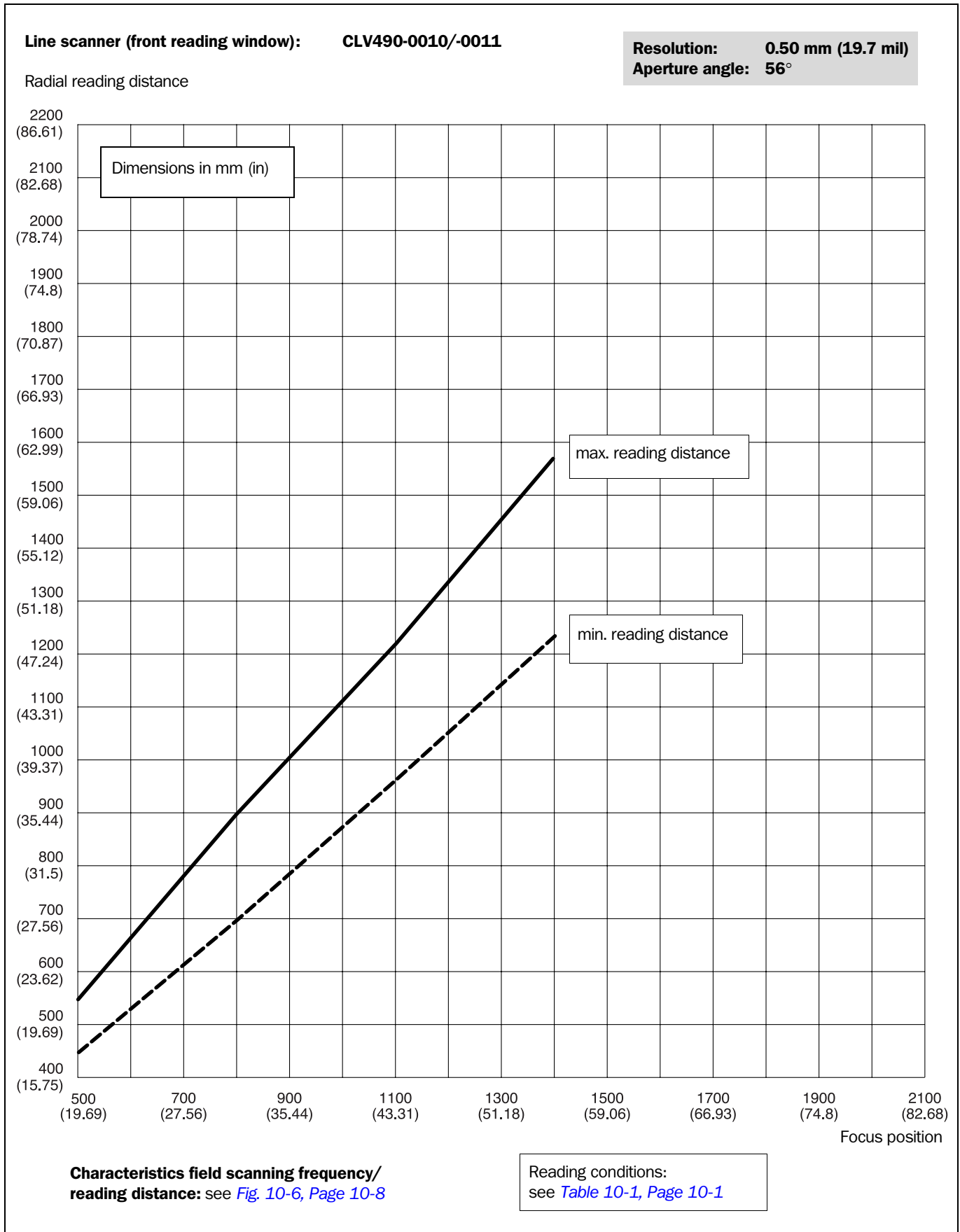

Fig. 10-5: CLV490-0010/-0011 (Standard density): Min. and Max. reading distance (measured radially) as a function of the focus position at a resolution of 0.50 mm (19.7 mil) and an aperture angle of $\alpha = 56^\circ$

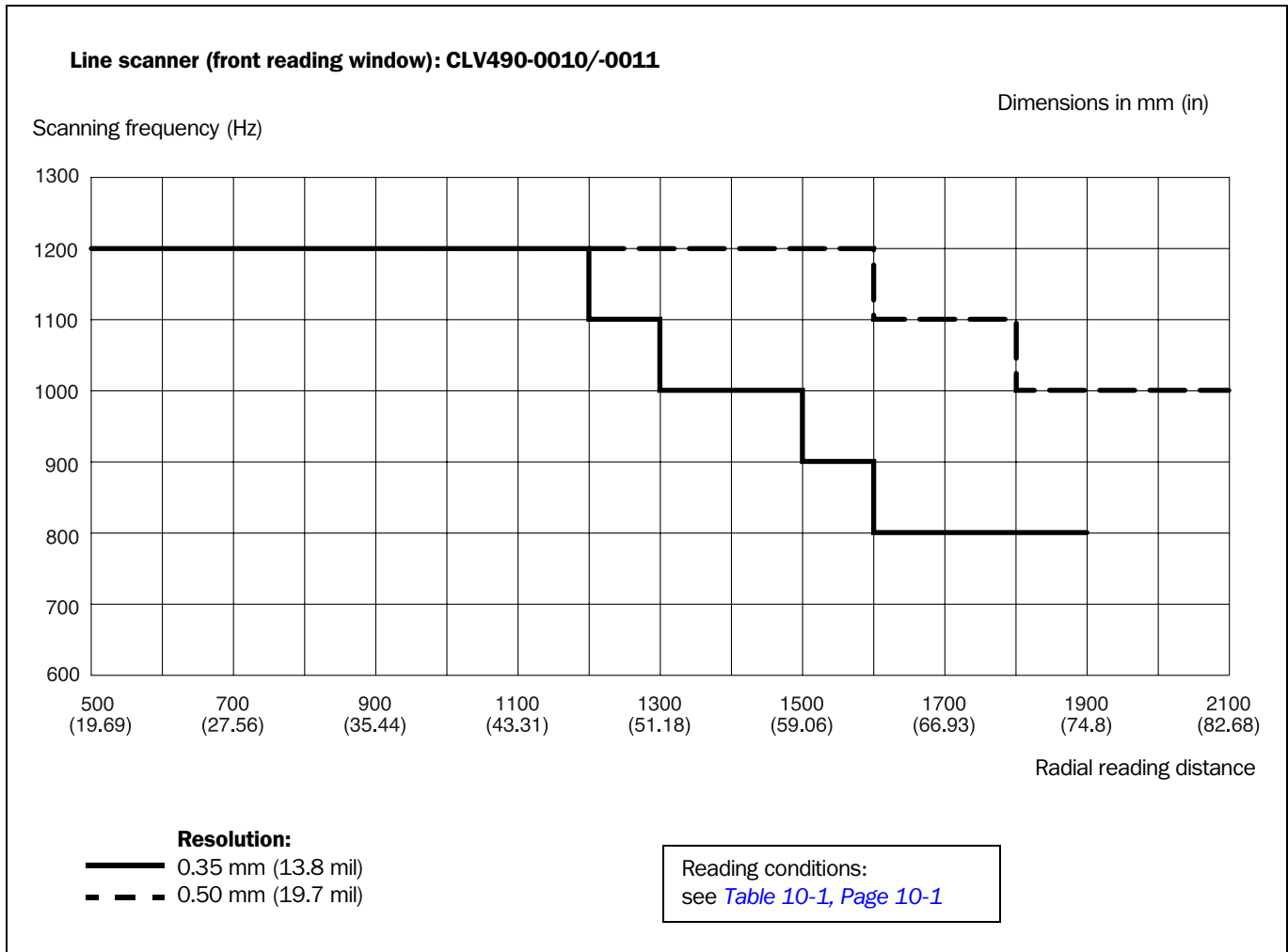

Fig. 10-6: Characteristics field CLV490-0010/-0011 (Standard density): Scanning frequency as a function of the radial reading distance and resolution

10.2.4 Standard density: Reading performance data of line scanner with oscillating mirror

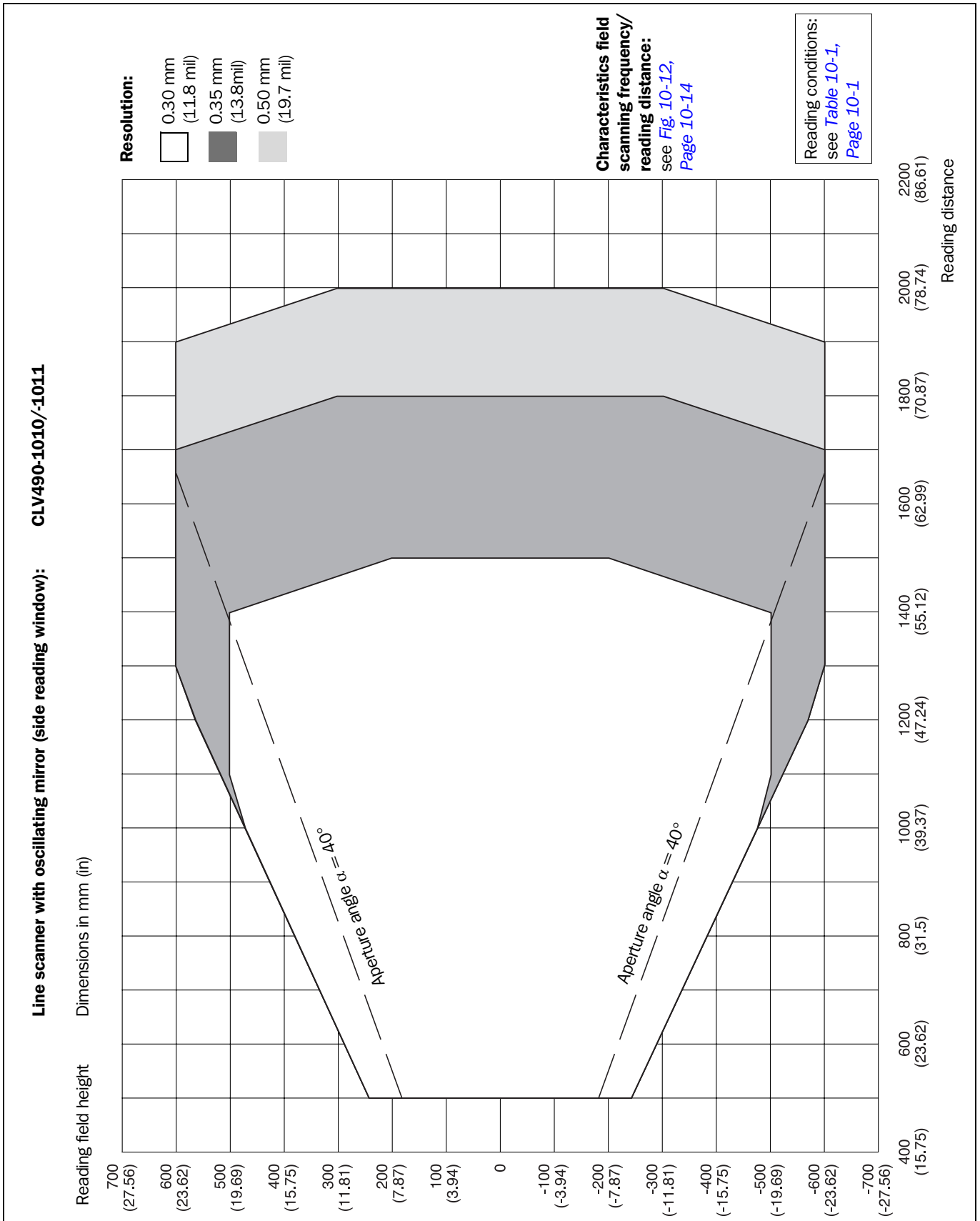

Fig. 10-7: CLV490-1010/-1011 (Standard density): Reading field height as a function of the reading distance and resolution

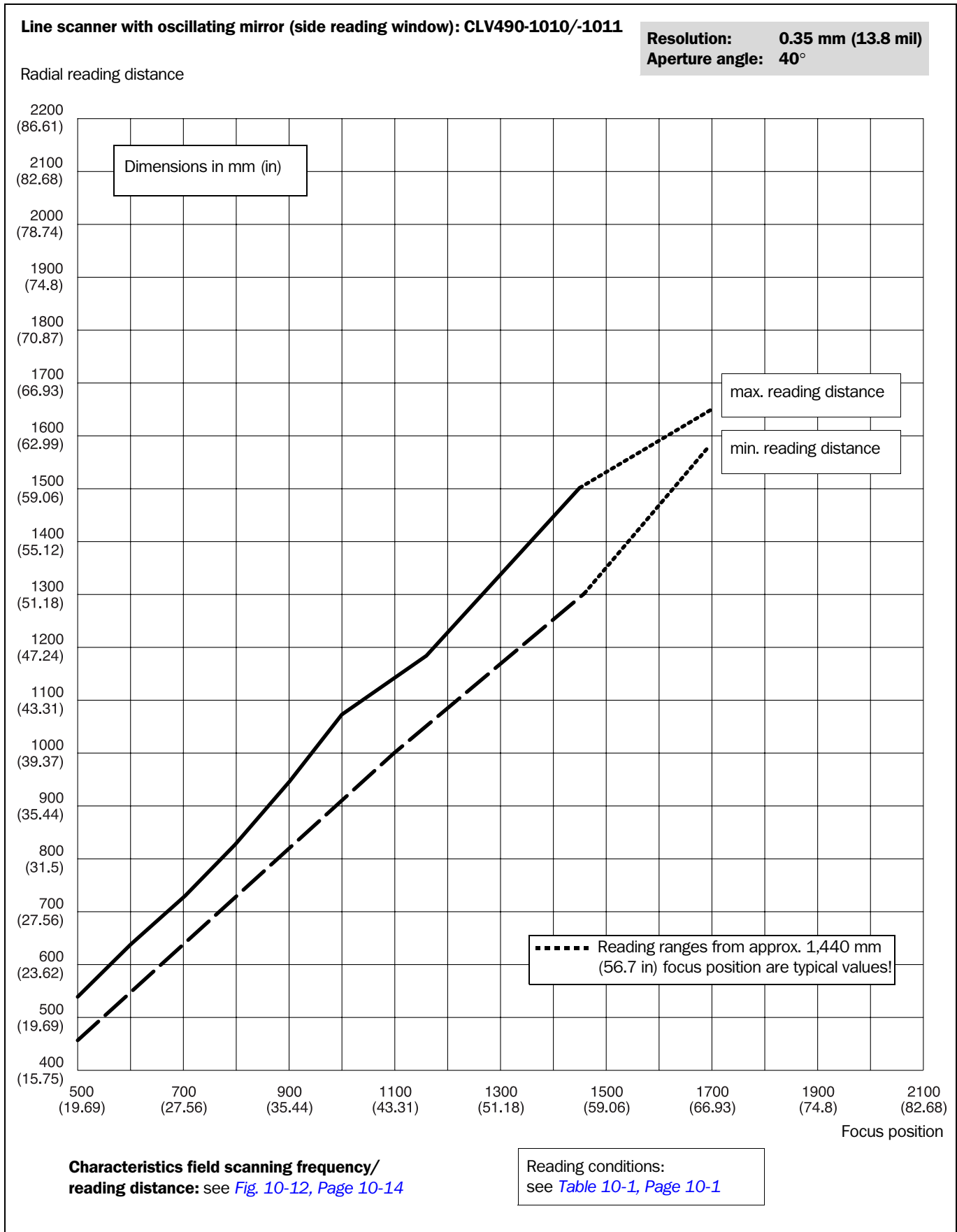

Fig. 10-8: CLV490-1010/-1011 (Standard density): Min. and Max. reading distance (measured radially) as a function of the focus position at a resolution of 0.35 mm (13.8 mil) and an aperture angle of $\alpha = 40^\circ$

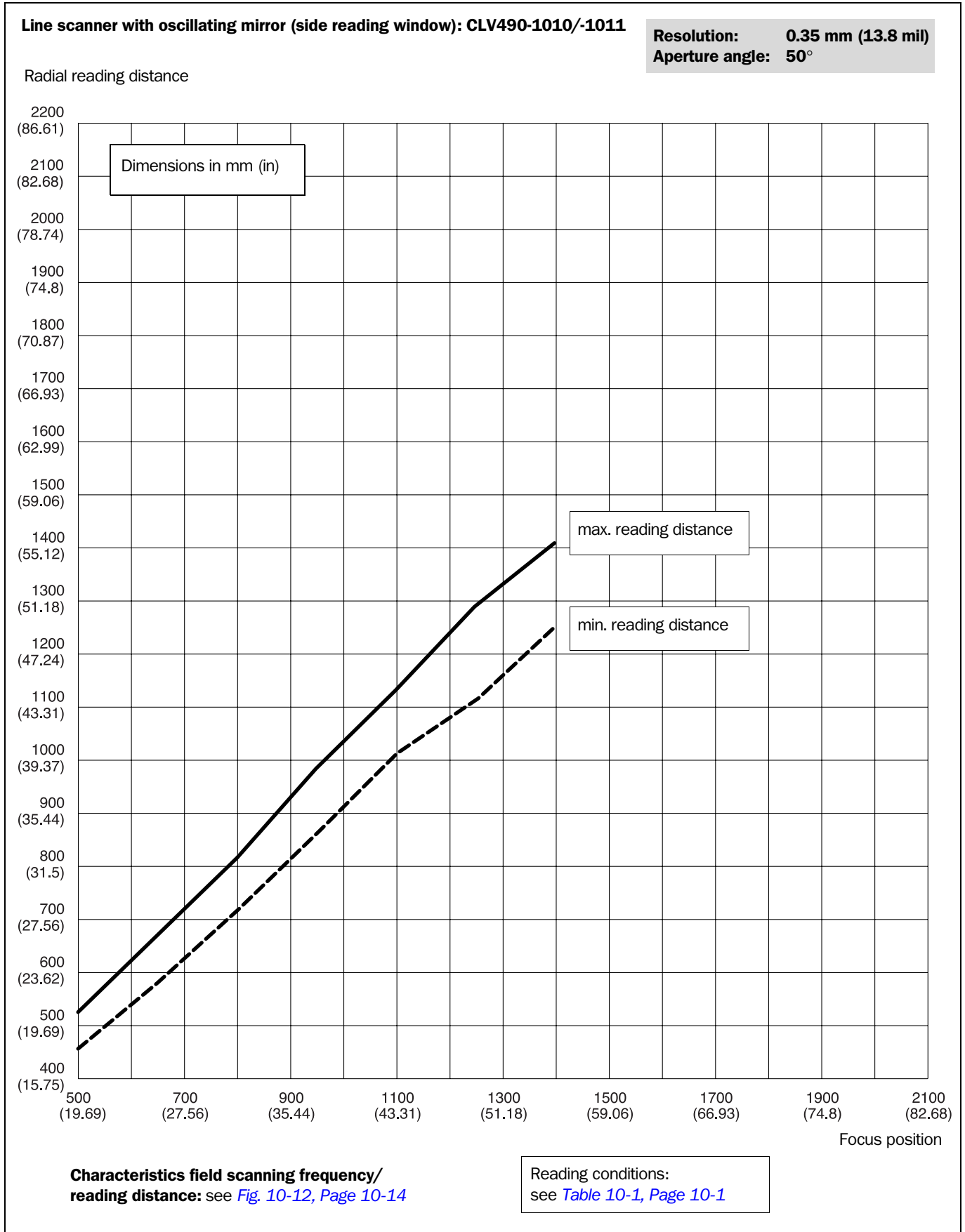

Fig. 10-9: CLV490-1010/-1011 (Standard density): Min. and Max. reading distance (measured radially) as a function of the focus position at a resolution of 0.35 mm (13.8 mil) and an aperture angle of $\alpha = 50^\circ$

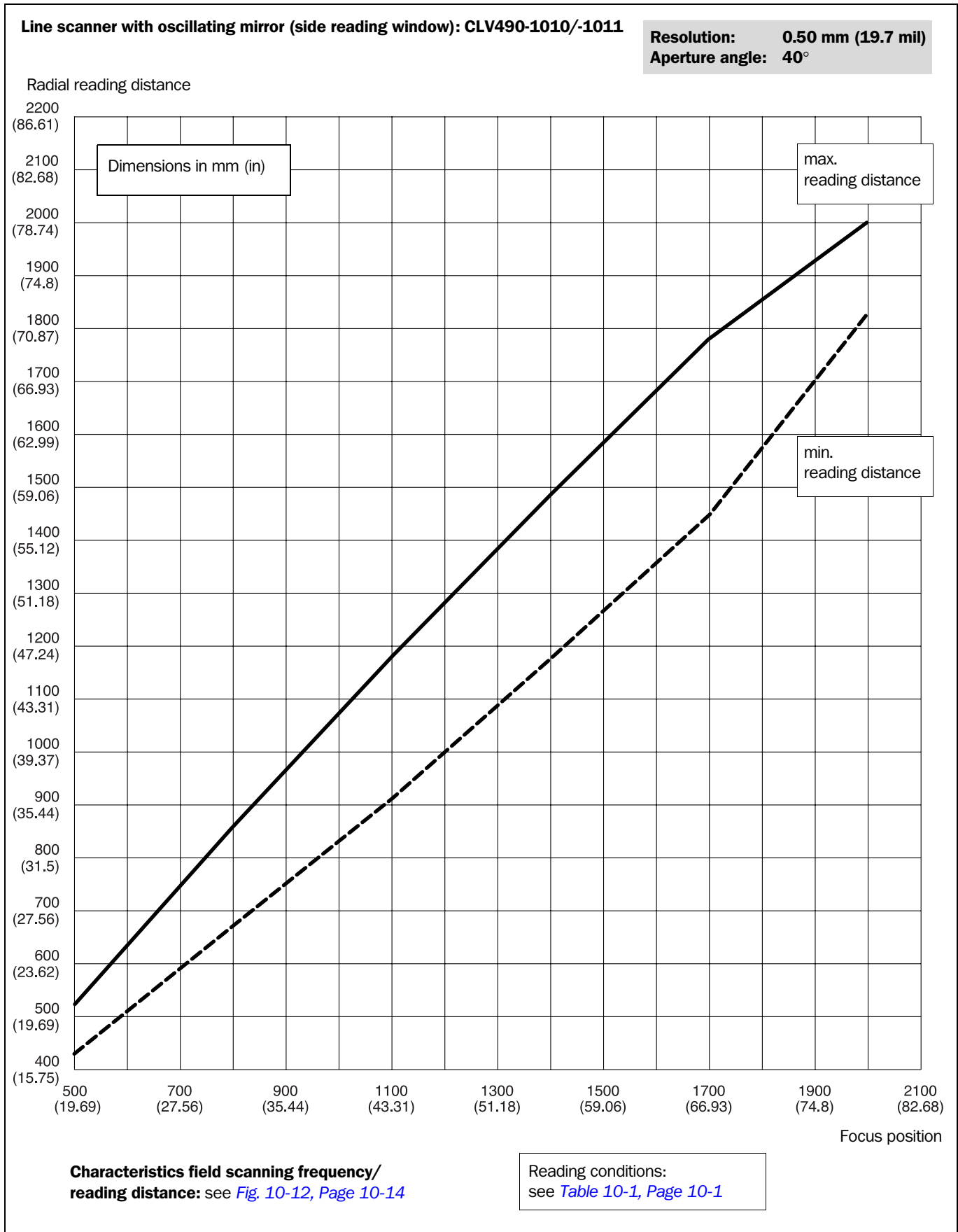

Fig. 10-10: CLV490-1010/-1011 (Standard density): Min. and Max. reading distance (measured radially) as a function of the focus position at a resolution of 0.50 mm (19.7 mil) and an aperture angle of $\alpha = 40^\circ$

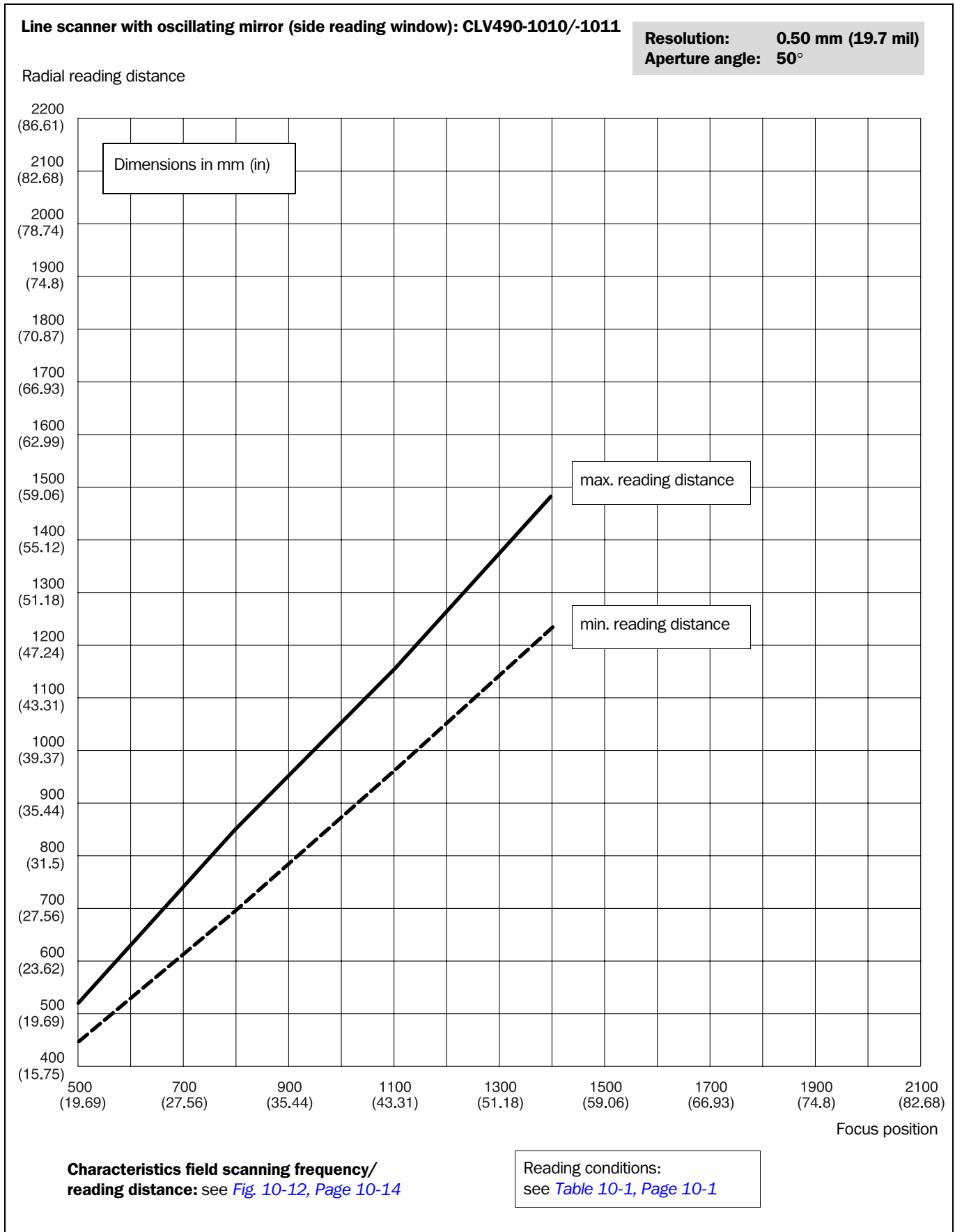

Fig. 10-11: CLV490-1010/-1011 (Standard density): Min. and Max. reading distance (measured radially) as a function of the focus position at a resolution of 0.50 mm (19.7 mil) and an aperture angle of $\alpha = 50^\circ$

Line scanner with oscillating mirror (side reading window): CLV490-1010/-1011

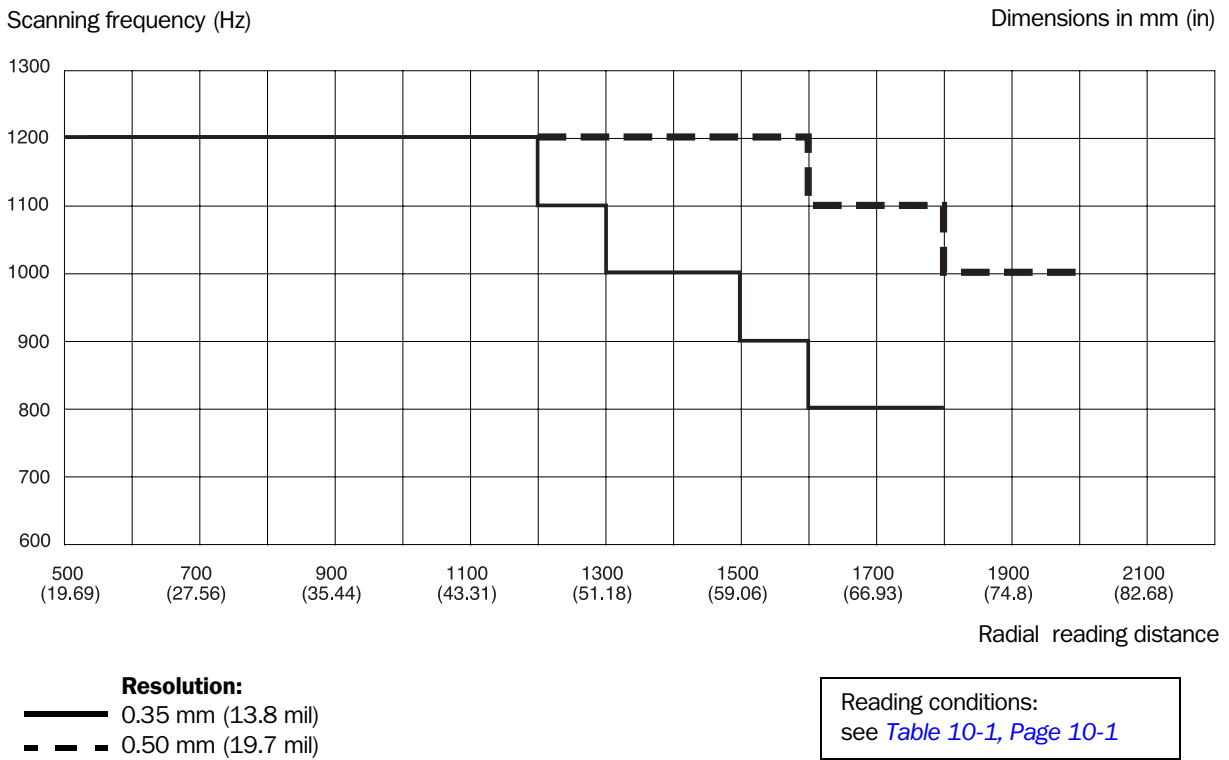

Fig. 10-12: Characteristics field CLV490-1010/-1011 (Standard density): Scanning frequency as a function of the radial reading distance and resolution

Line scanner with oscillating mirror (side reading window): CLV490-1010/-1011

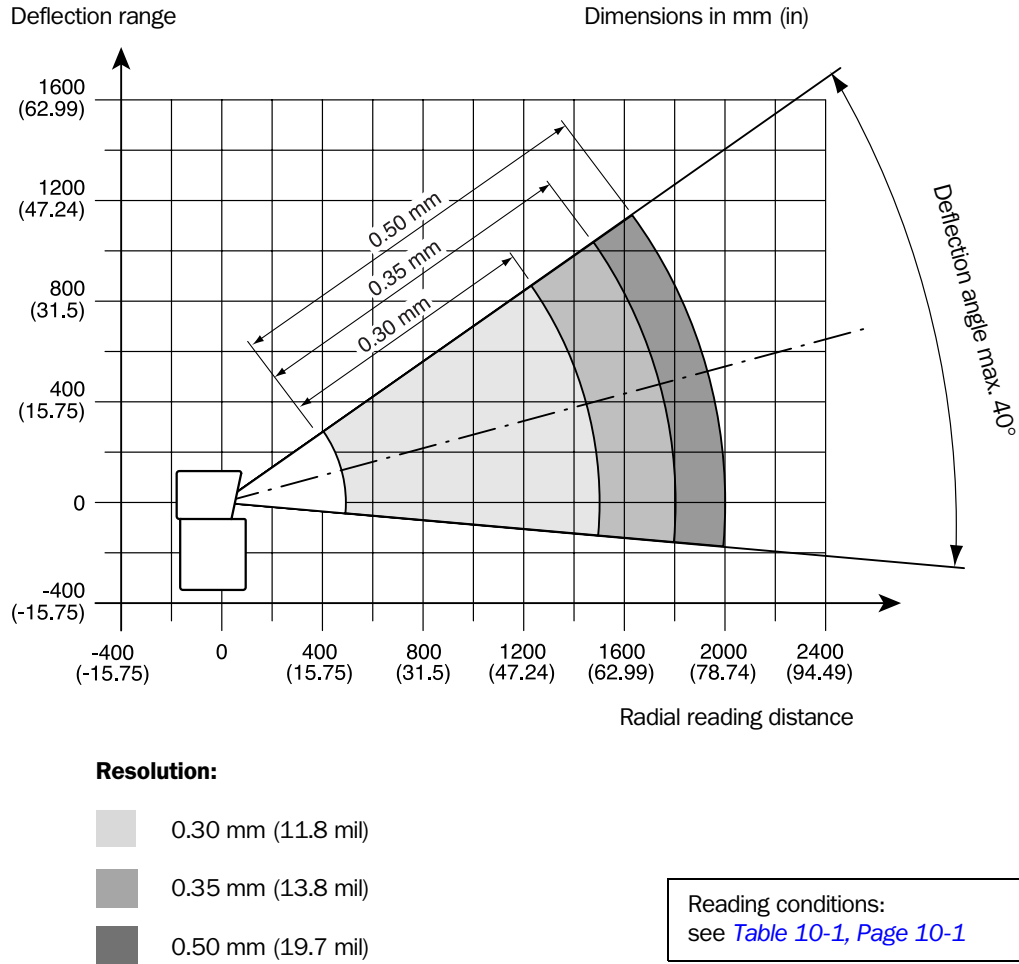

Fig. 10-13: CLV490-1010/-1011 (Standard density): deflection range as a function of radial reading distance, deflection angle and resolution

10.2.5 High density: Reading performance data of line scanner

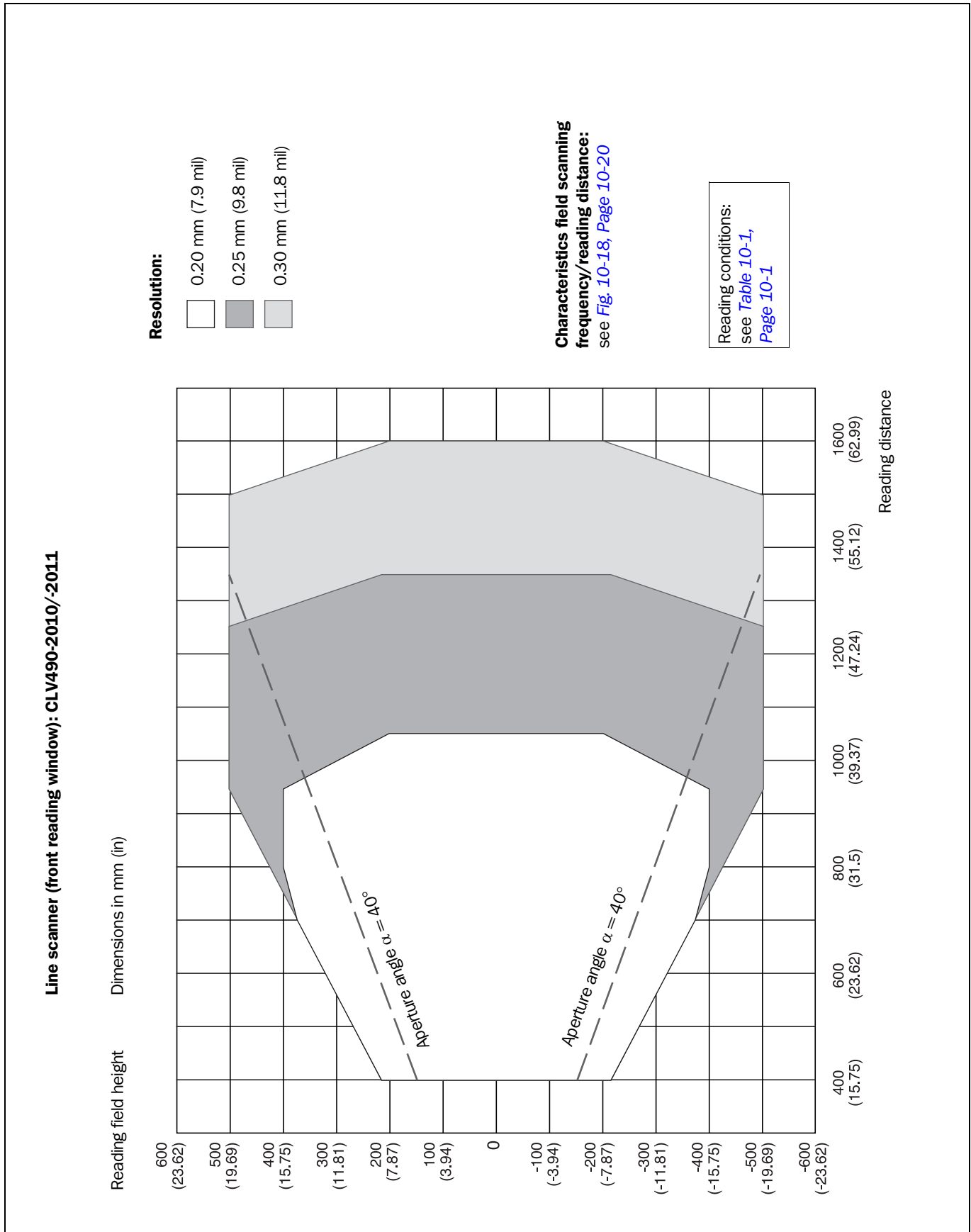

Fig. 10-14: CLV490-2010/-2011 (High density): Reading field height as a function of the reading distance and resolution

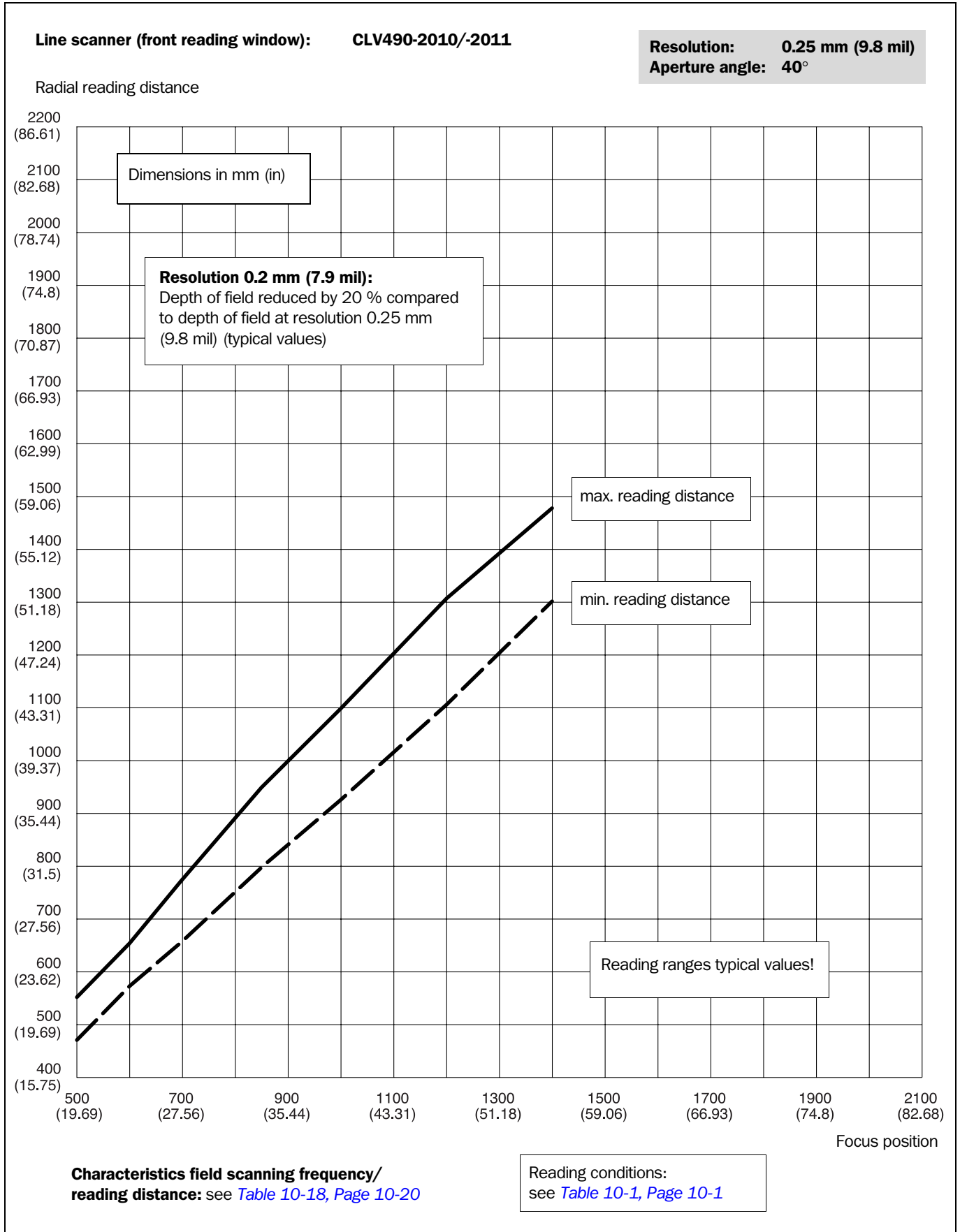

Fig. 10-15: CLV490-2010/-2011 (High density): Min. and Max. reading distance (measured radially) as a function of the focus position at a resolution of 0.25 mm (9.8 mil) and an aperture angle of $\alpha = 40^\circ$

Line scanner (front reading window): **CLV490-2010/-2011**

Resolution: 0.35 mm (13.8 mil)
Aperture angle: 40°

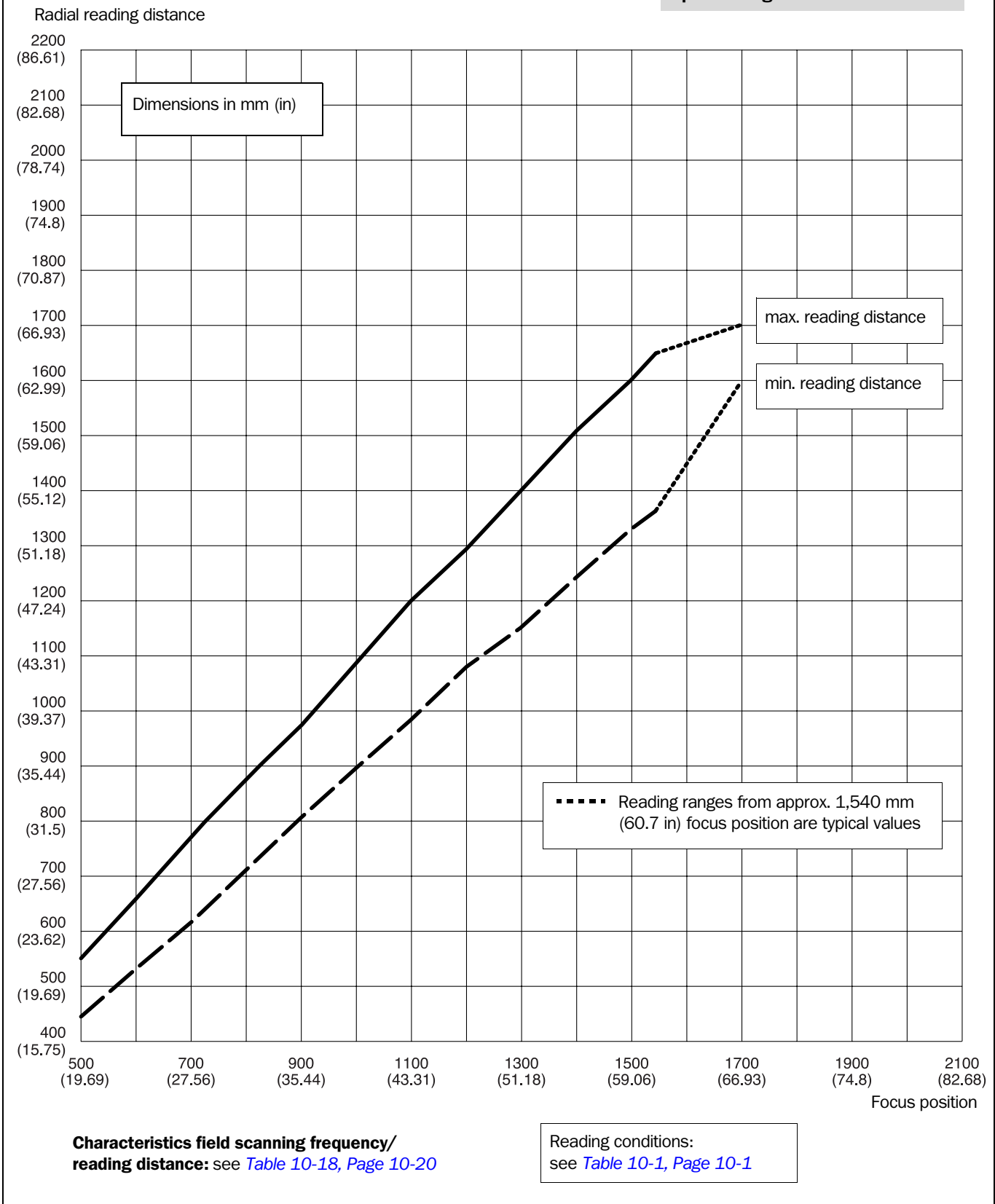

Fig. 10-16: CLV490-2010/-2011 (High density): Min. and Max. reading distance (measured radially) as a function of the focus position at a resolution of 0.35 mm (13.8 mil) and an aperture angle of $\alpha = 40^\circ$

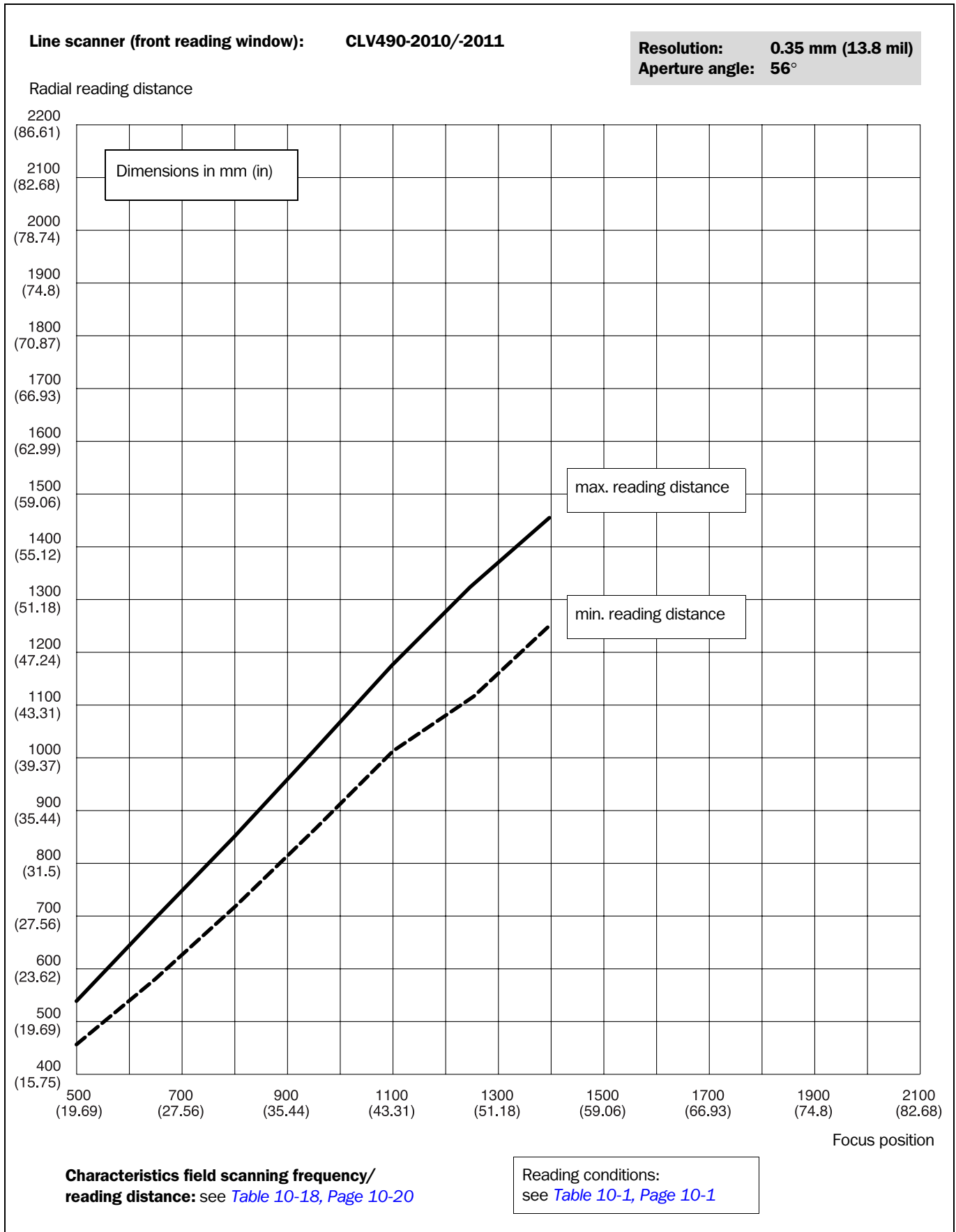

Fig. 10-17: CLV490-2010/-2011 (High density): Min. and Max. reading distance (measured radially) as a function of the focus position at a resolution of 0.35 mm (13.8 mil) and an aperture angle of $\alpha = 56^\circ$

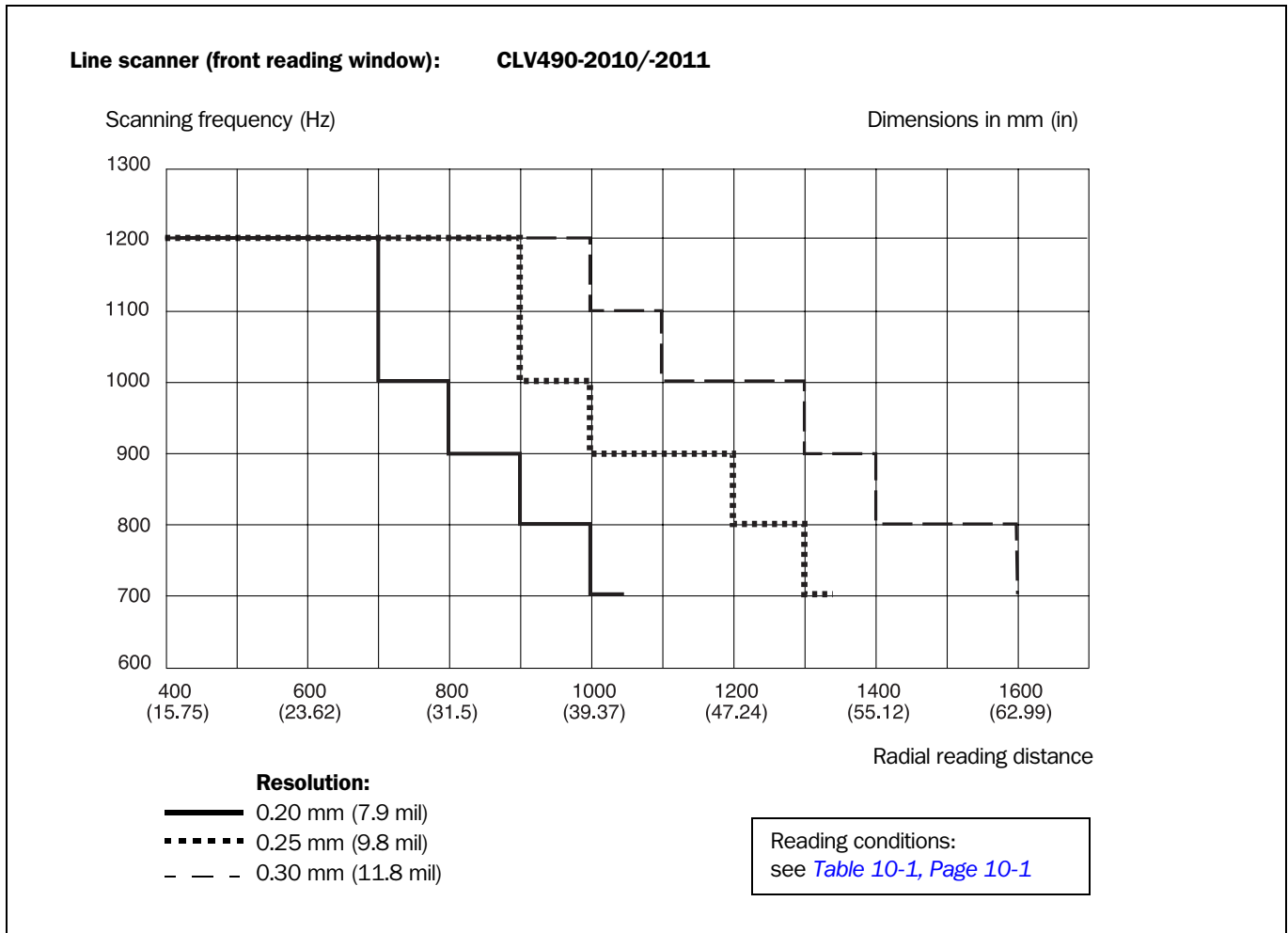

Fig. 10-18: Characteristics field CLV490-2010/-2011 (High density): Scanning frequency as a function of the radial reading distance and resolution

10.2.6 High density: Reading performance data line scanner with oscillating mirror

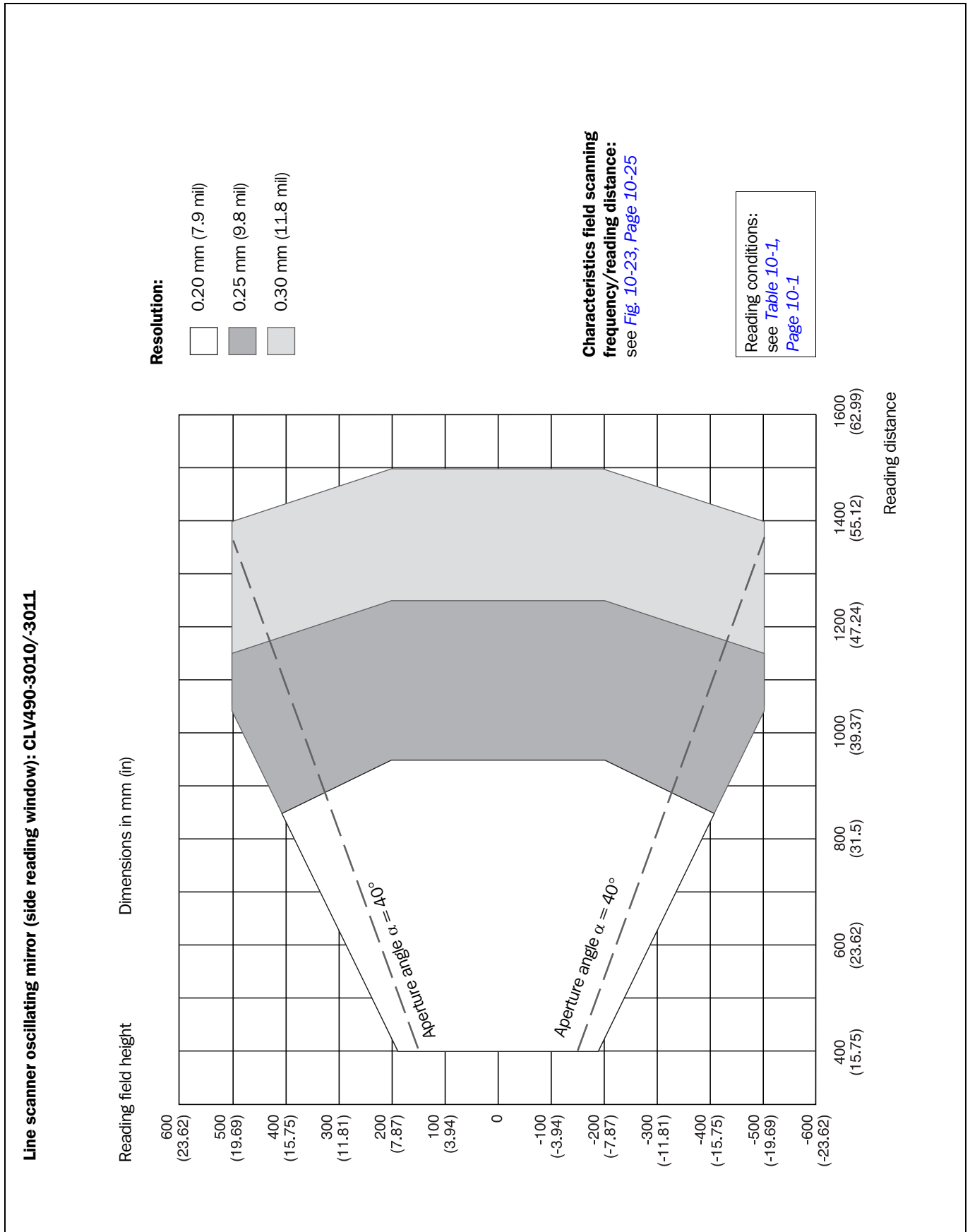

Fig. 10-19: CLV490-3010/-3011 (High density): Reading field height as a function of the reading distance and resolution

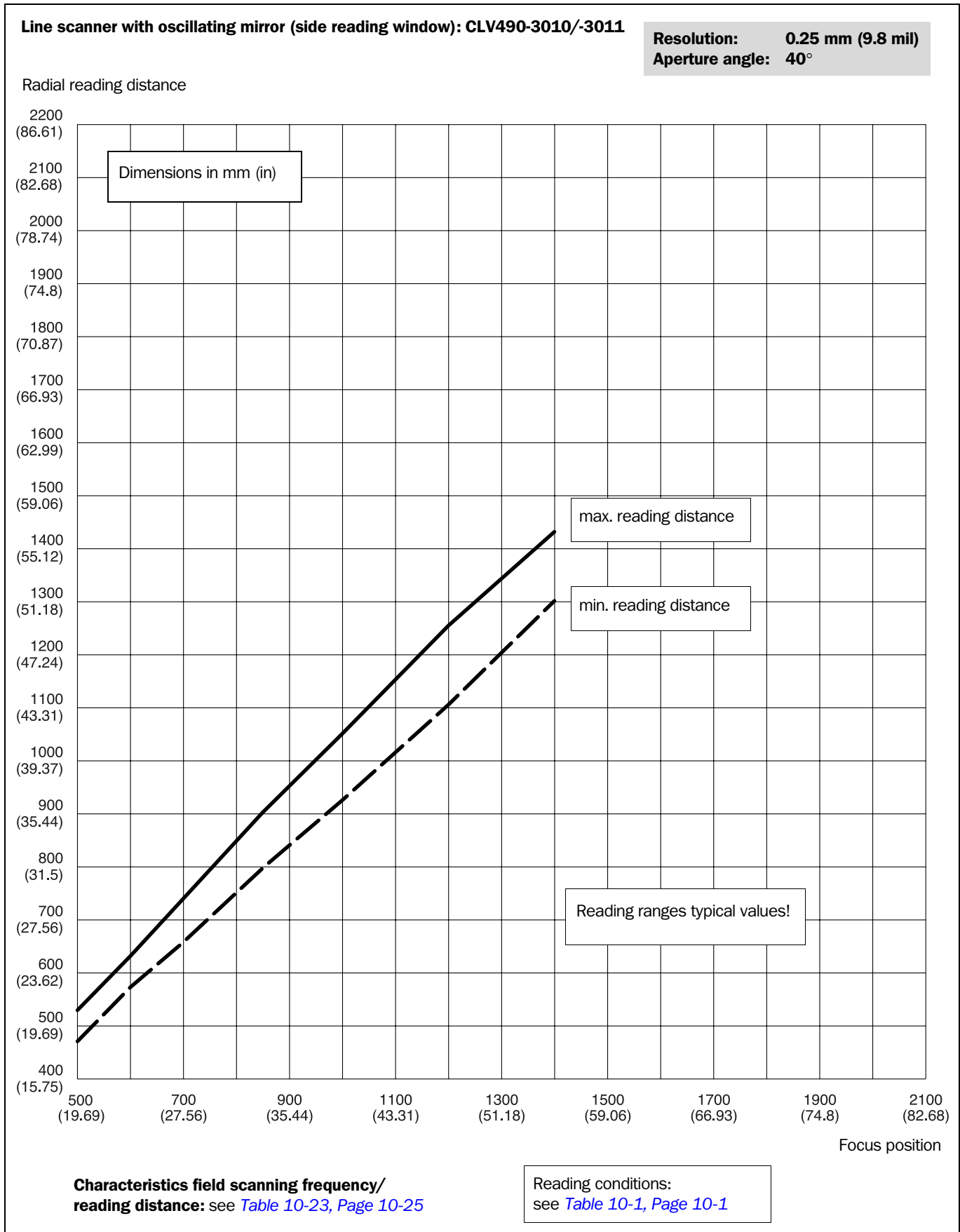

Fig. 10-20: CLV490-3010/-3011: (High density) Min. and Max. reading distance (measured radially) as a function of the focus position at a resolution of 0.25 mm (9.8 mil) and an aperture angle of $\alpha = 40^\circ$

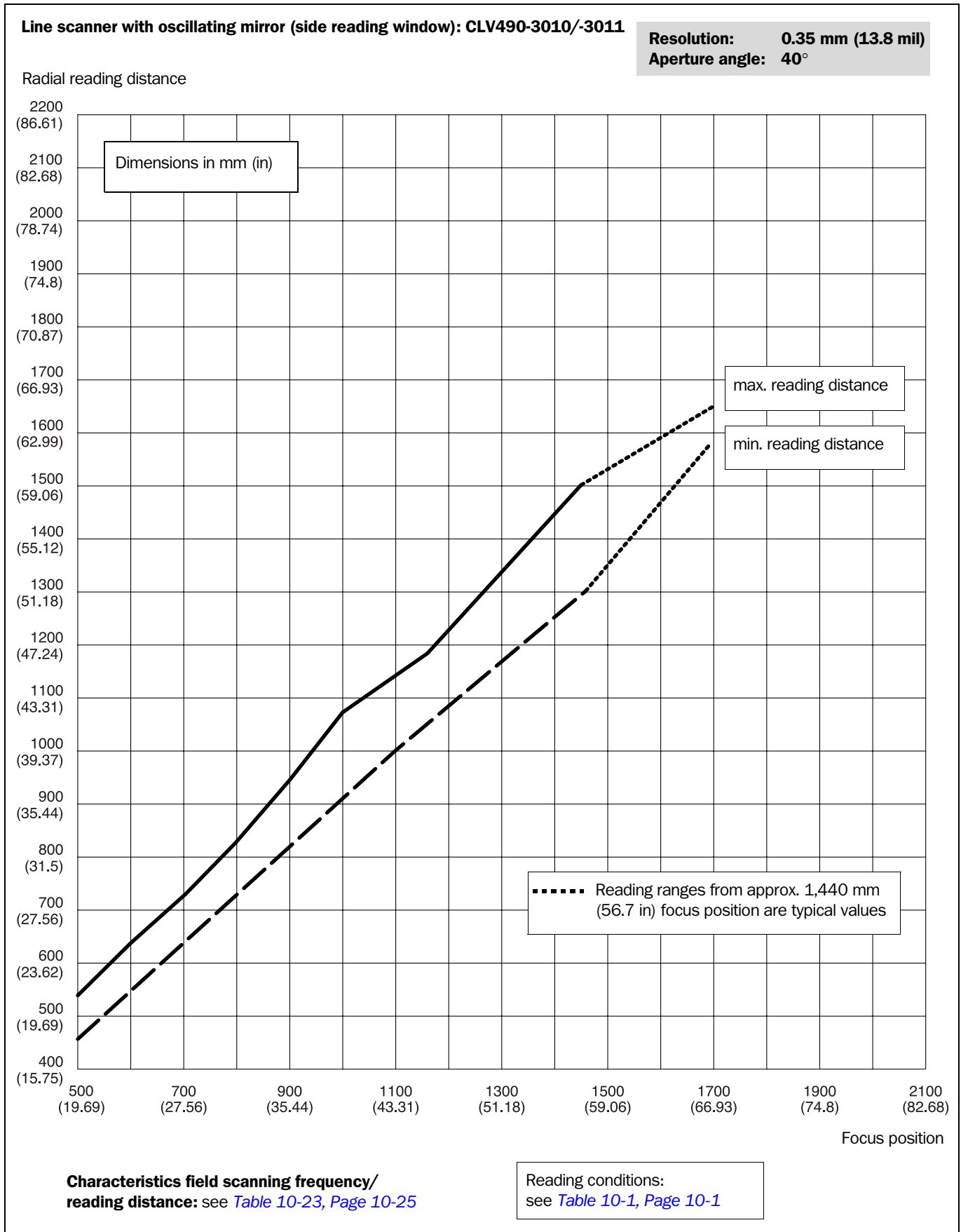

Fig. 10-21: CLV490-3010/-3011 (High density): Min. and Max. reading distance (measured radially) as a function of the focus position at a resolution of 0.35 mm (13.8 mil) and an aperture angle of $\alpha = 40^\circ$

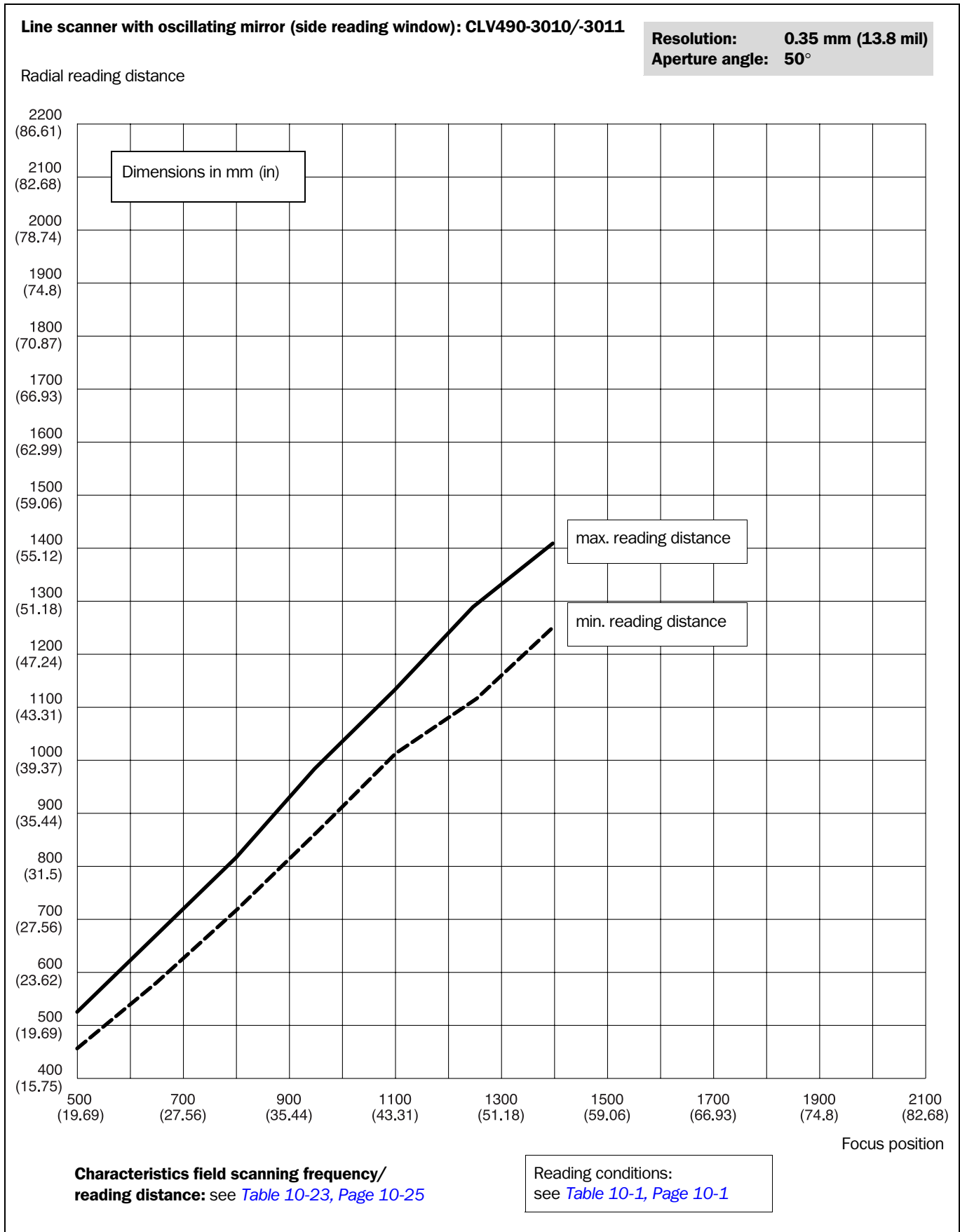

Fig. 10-22: CLV490-3010/-3011 (High density): Min. and Max. reading distance (measured radially) as a function of the focus position at a resolution of 0.35 mm (13.8 mil) and an aperture angle of $\alpha = 50^\circ$

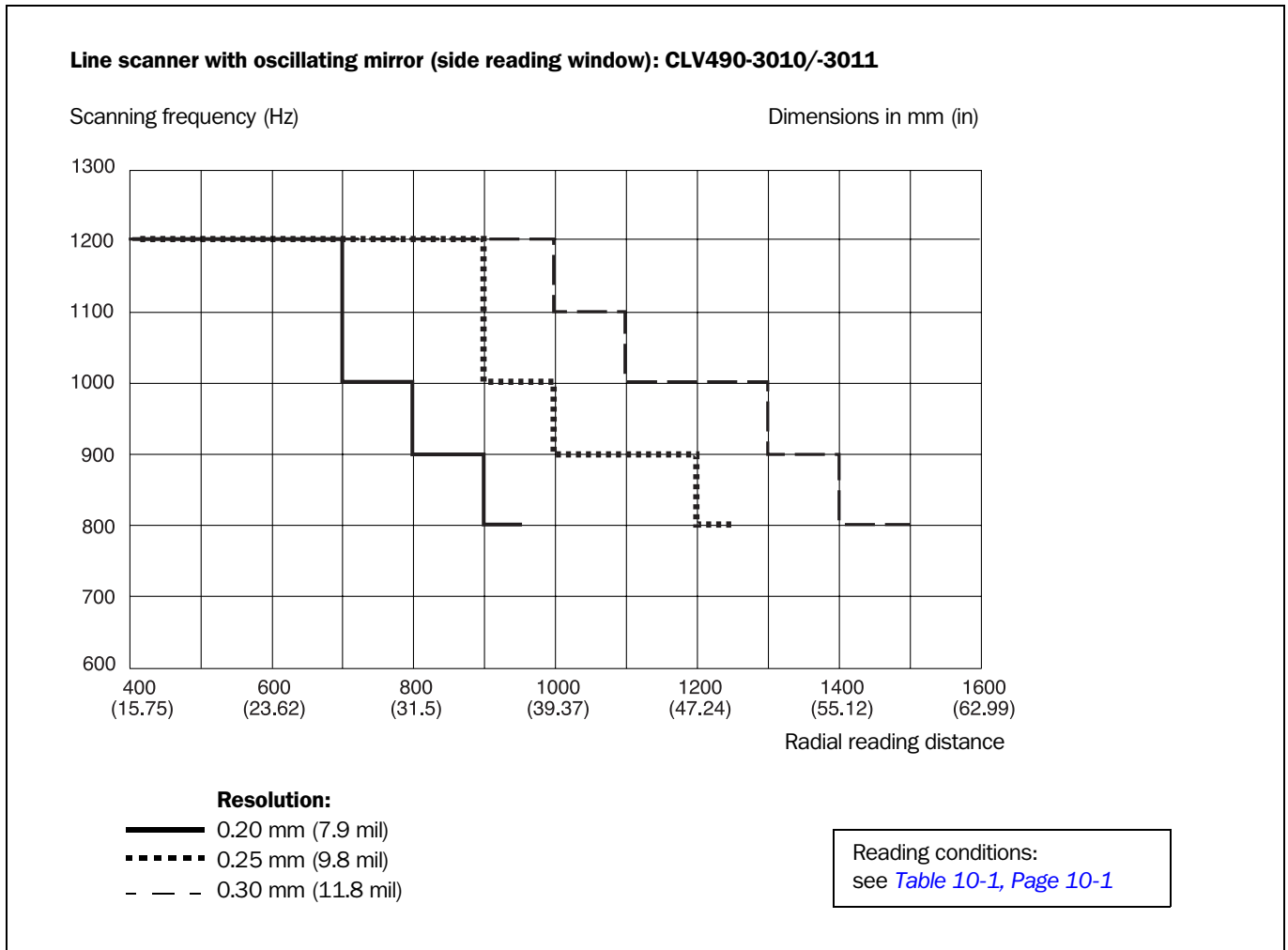

Fig. 10-23: Characteristics field CLV490-3010/-3011 (High density): Scanning frequency as a function of the radial reading distance and resolution

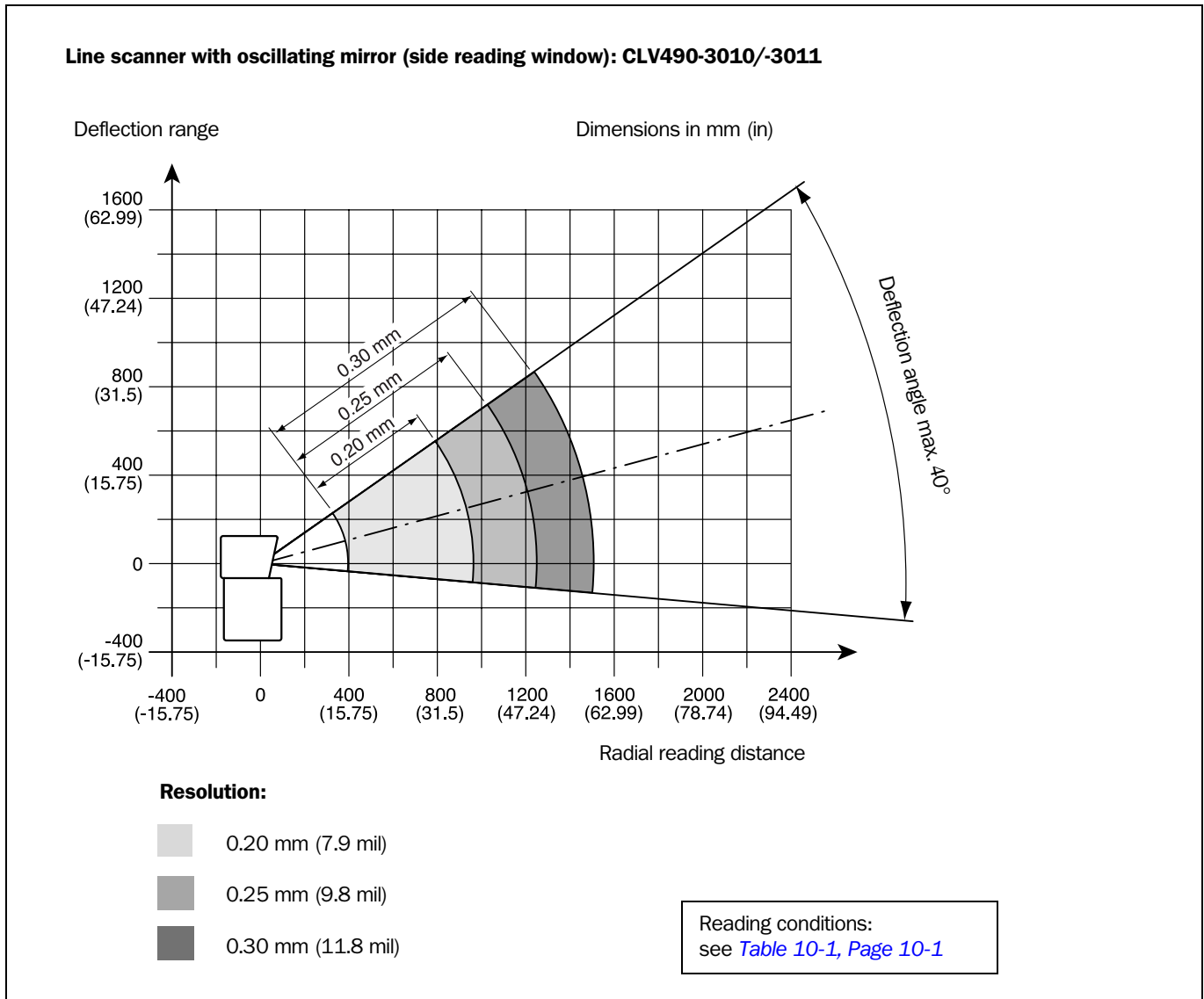

Fig. 10-24: CLV490-3010/-3011 (High density): Deflection range as a function of radial reading distance, deflection angle and resolution

10.2.7 Low density: Reading performance data of line scanner

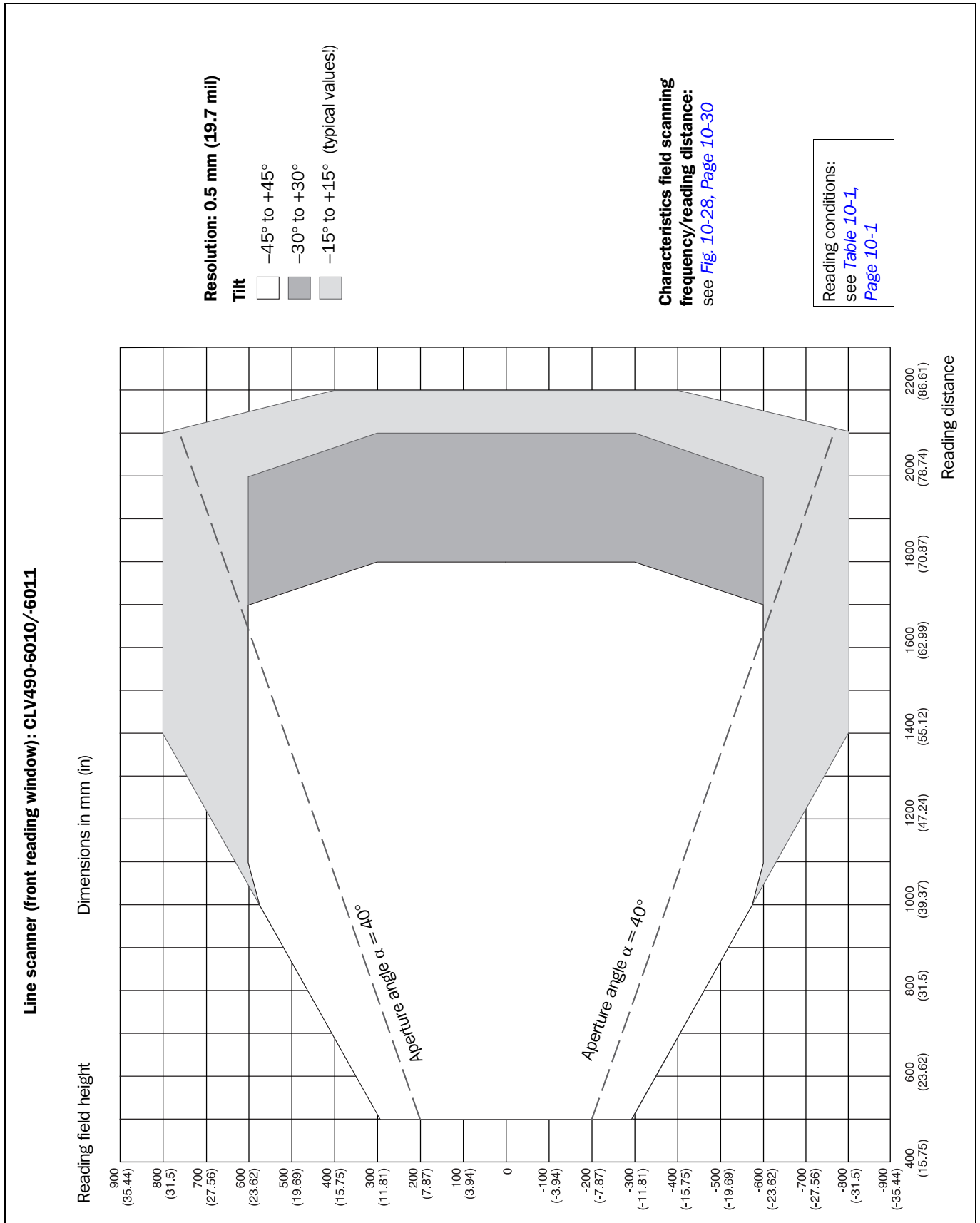

Fig. 10-25: CLV490-6010/-6011 (Low density): Reading field height as a function of the reading distance and the tilt at a resolution of 0.5 mm (19.7 mil)

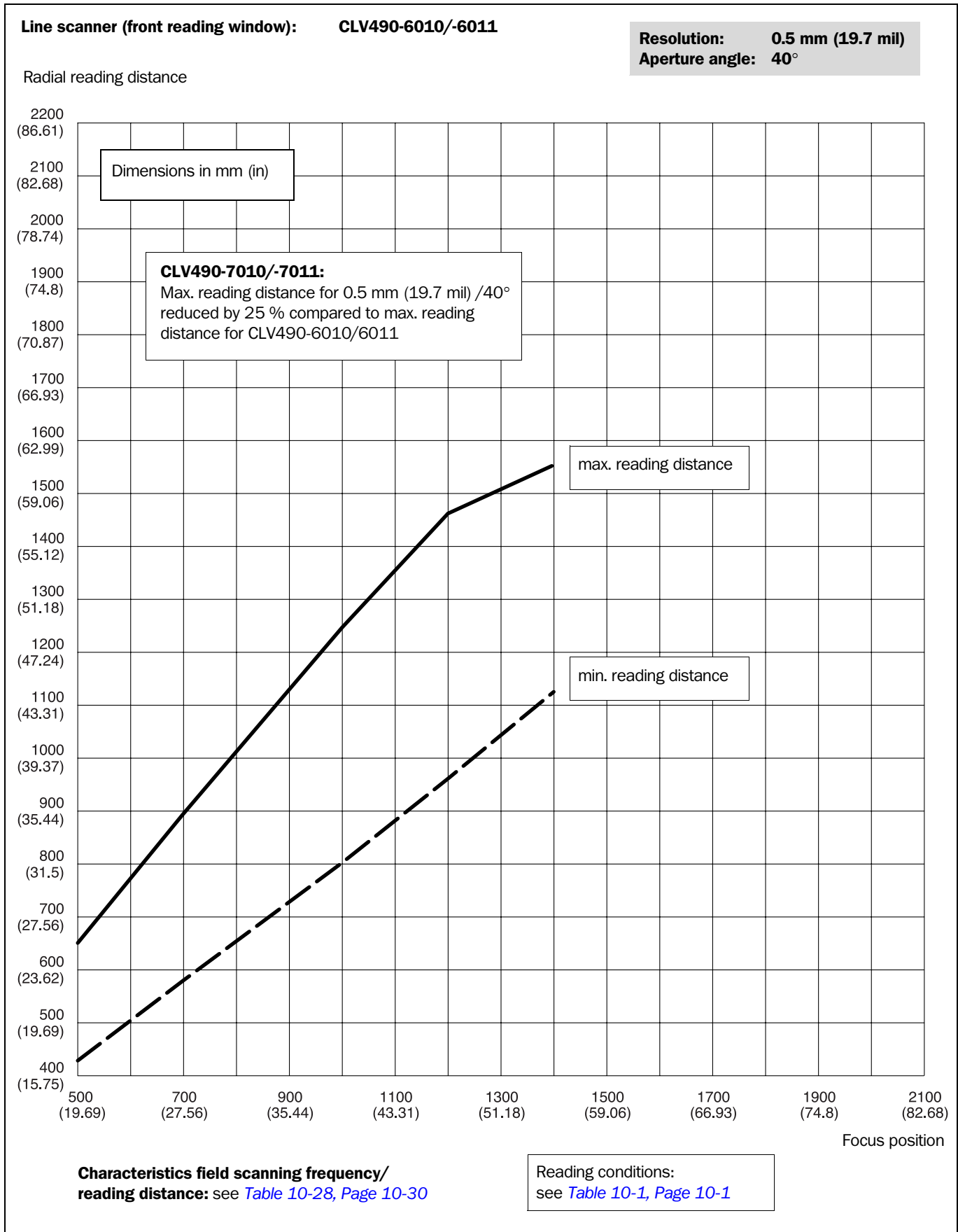

Fig. 10-26: CLV490-6010/-6011 (Low density): Min. and Max. reading distance (measured radially) as a function of the focus position at a resolution of 0.5 mm (19.7 mil) and an aperture angle of $\alpha = 40^\circ$

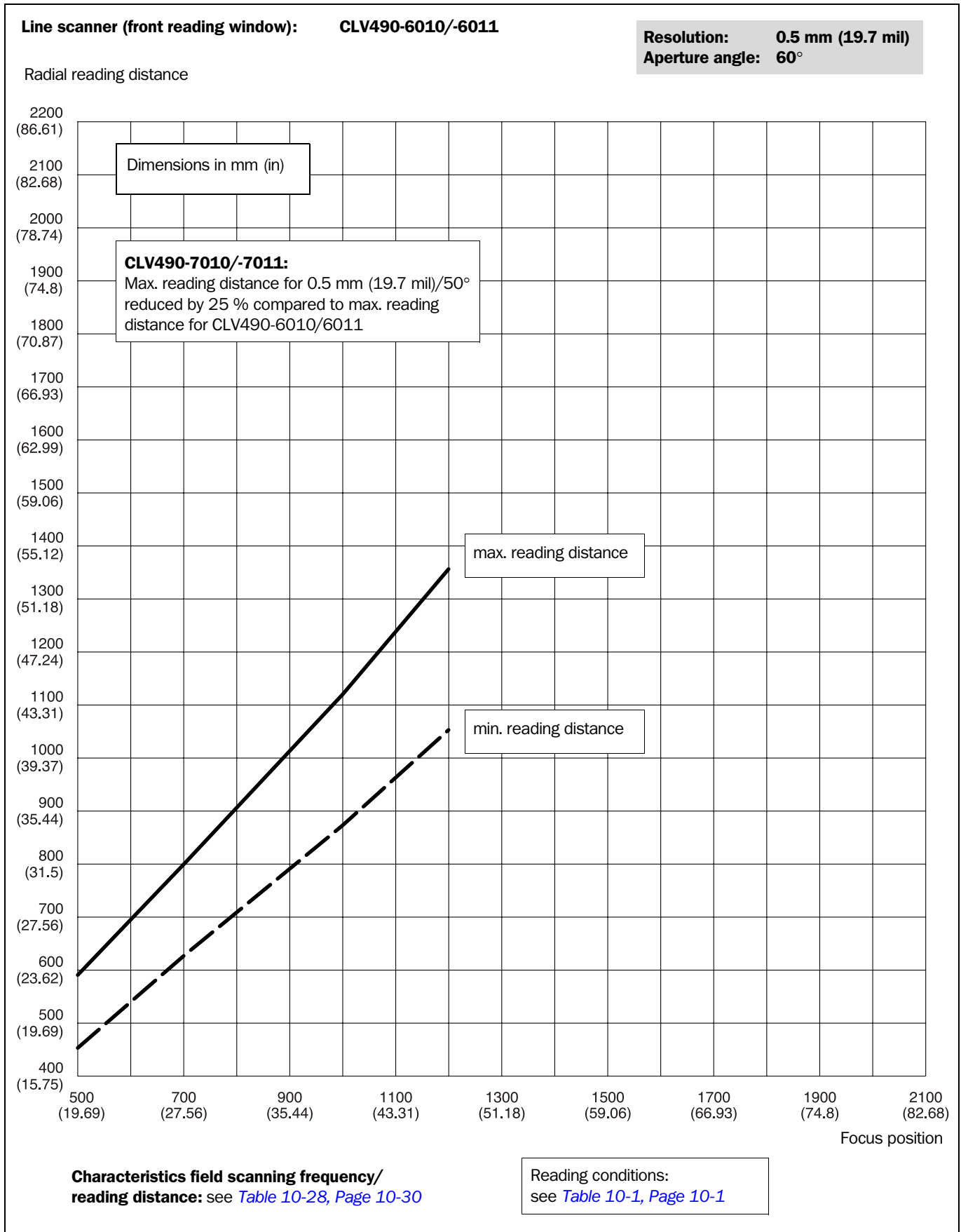

Fig. 10-27: CLV490-6010/-6011 (Low density): Min. and Max. reading distance (measured radially) as a function of the focus position at a resolution of 0.5 mm (19.7 mil) and an aperture angle of $\alpha = 60^\circ$

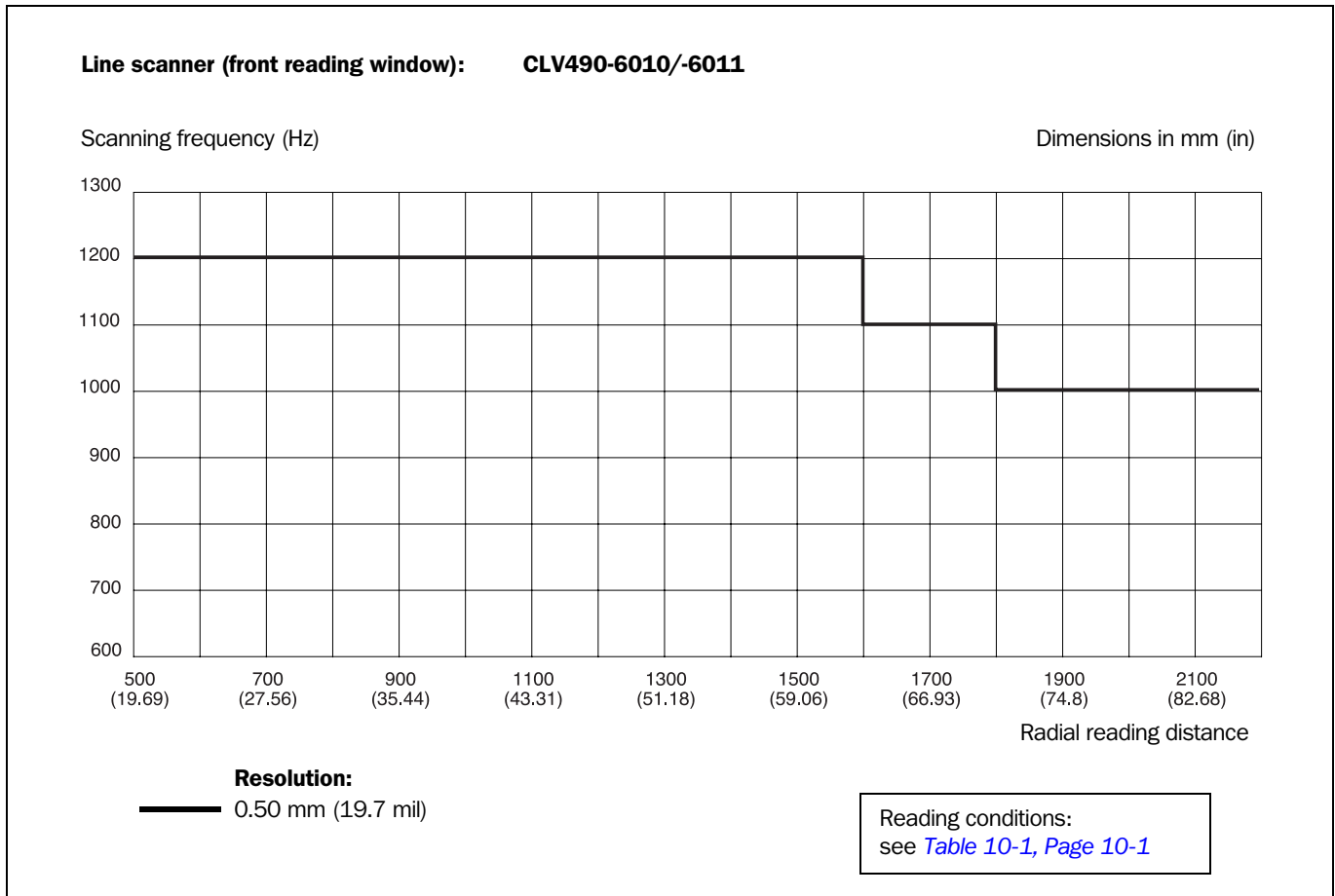

Fig. 10-28: Characteristics field CLV490-6010/-6011 (Low density): Scanning frequency as a function of the radial reading distance and resolution

10.2.8 Low density: Reading performance data of line scanner with oscillating mirror

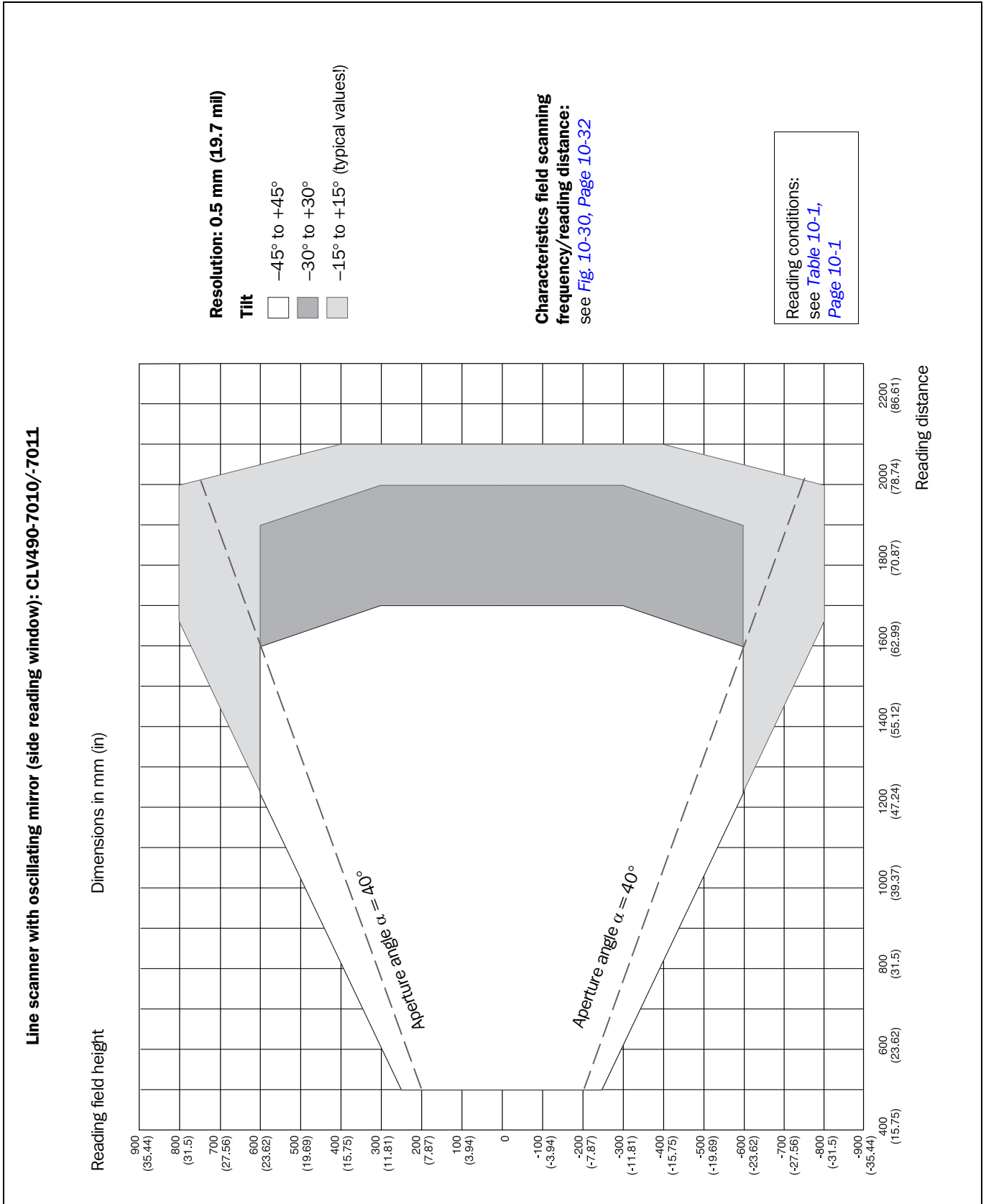

Fig. 10-29: CLV490-7010/-7011 (Low density): Reading field height as a function of the reading distance and tilt at a resolution of 0.5 mm (19.7 mil)

Reading distance at a resolution of 0.5 mm (19.7 mil)/aperature angle 40°

see [Fig. 10-26, Page 10-28](#)

Reading distance at a resolution of 0.5 mm (19.7 mil)/aperature angle 50°

see [Fig. 10-27, Page 10-29](#)

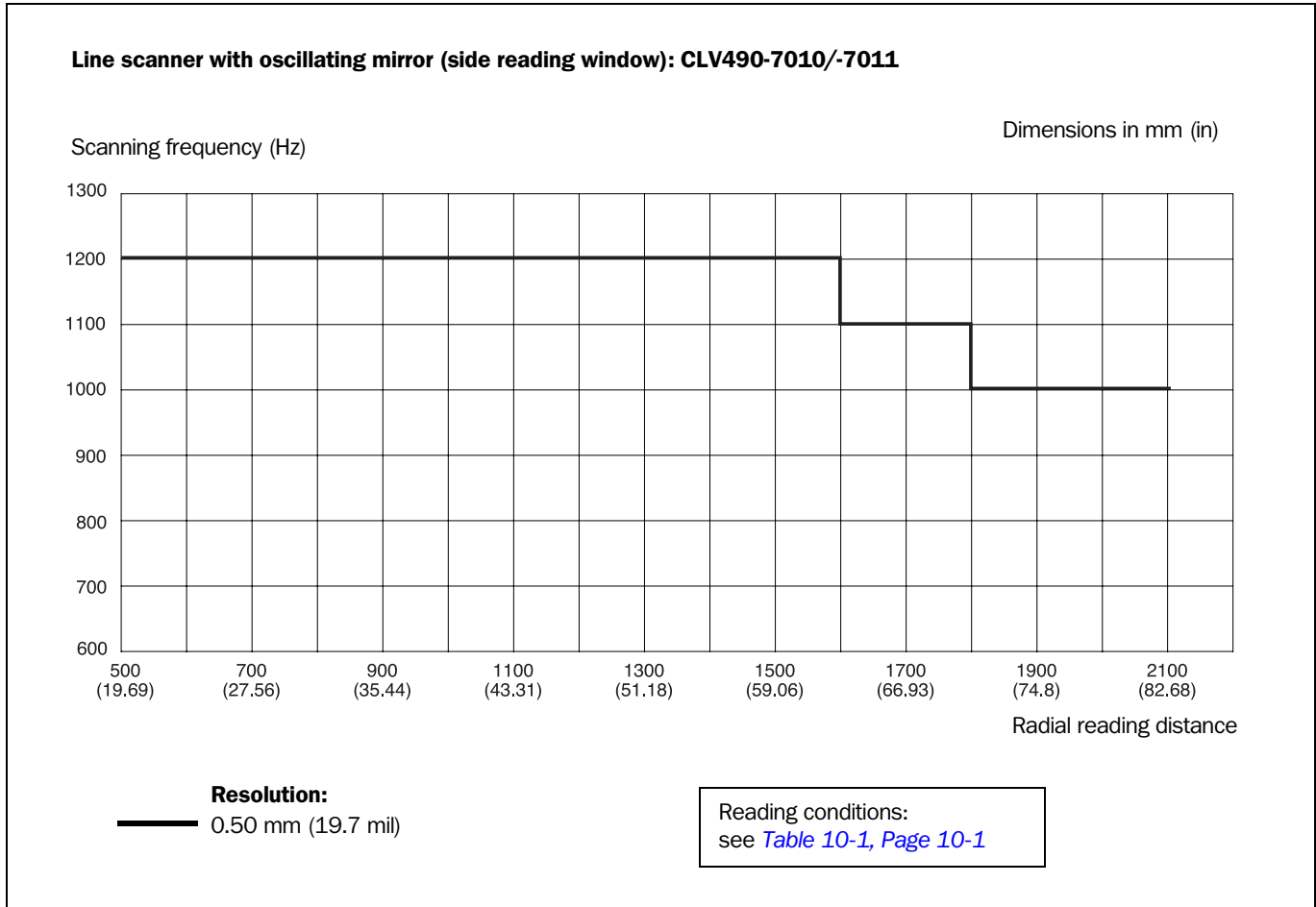

Fig. 10-30: Characteristics field CLV490-7010/-7011 (Low density): Scanning frequency as a function of the radial reading distance and resolution

Line scanner with oscillating mirror (side reading window): CLV490-7010/-7011

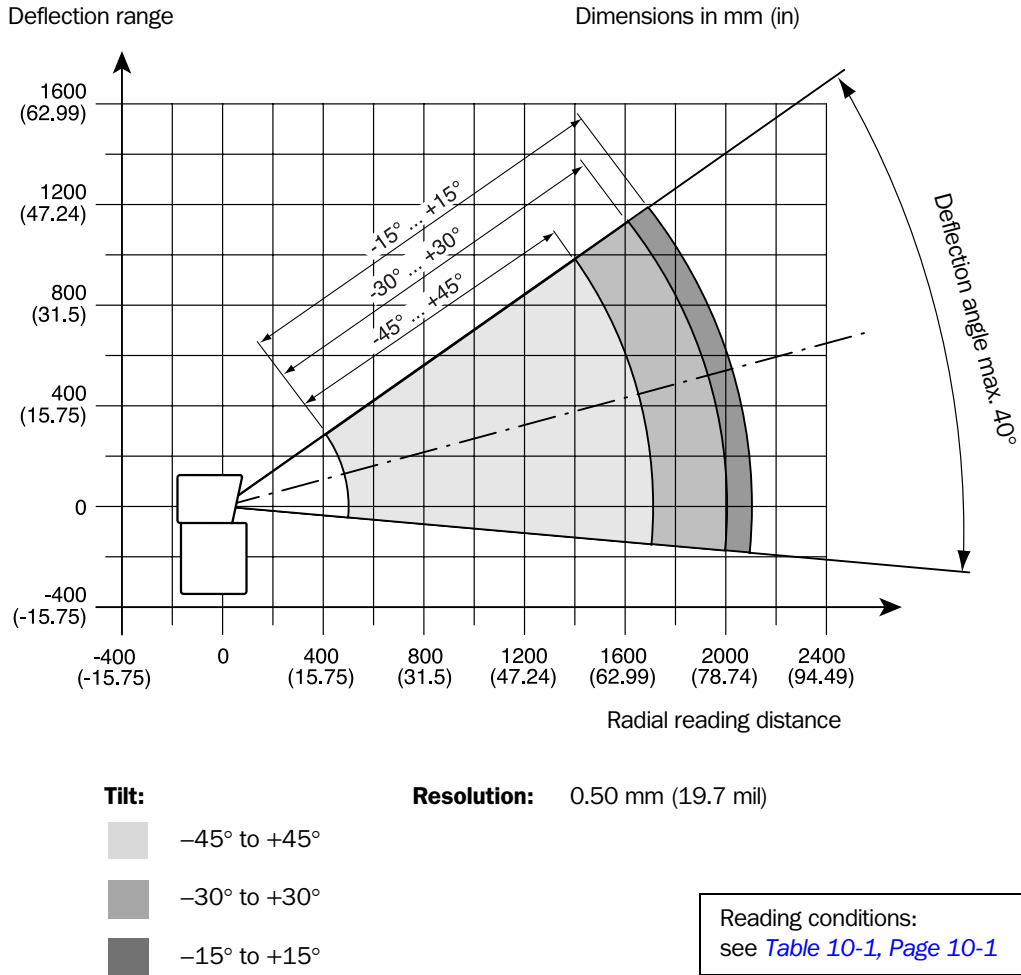

Fig. 10-31: CLV490-7010/-7011 (Low density): Deflection range as a function of radial reading distance, deflection angle and tilt at a resolution of 0.5 mm (19.7 mil)

10.3 Installing and operating the external parameter memory (connector cover)

The external parameter memory is available as an accessory. It is located in a connector cover and comprises a permanent, rewriteable memory (EEPROM) with 4 kByte from CLV490 firmware V 2.0. The connector cover covers the two connections of the CLV490 in the enclosure rating IP 65. The cover is shown in [Fig. 10-32](#). Depending on the type, two (one) connection cable(s) that are secured by means of conduit thread connections supply the signals of the CLV490 with identical pin assignment or limited pin assignment.

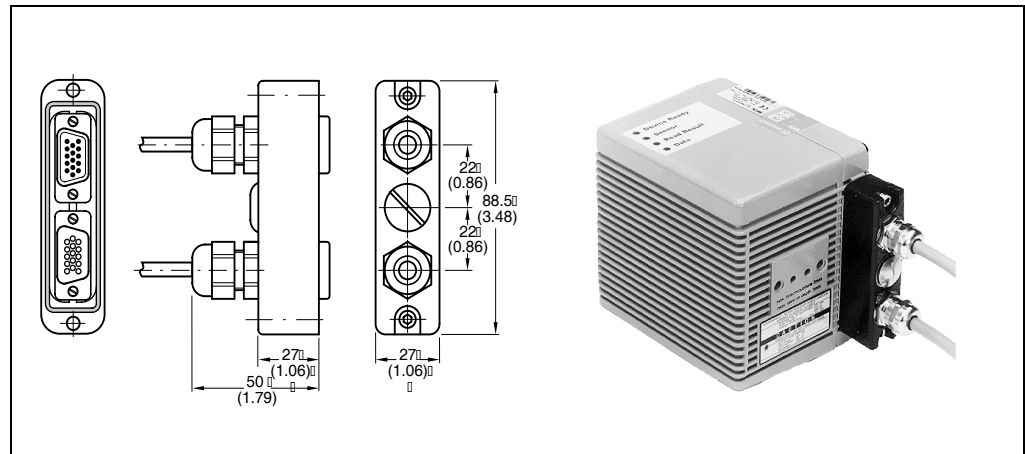

Fig. 10-32: External parameter memory, installed on the CLV490

Note If the CLV490 is used to replace a CLV 265/CLV 295 equipped with a connector cover (parameter memory), the CLV490 cannot store its extensive parameter set in this external parameter memory (too small).

The parameter memory in the connector cover is available in different implementations:

Order no.	Design	CLV490	Length	Connection
2030023	Connector cover, one connection cable with 15-pin D Sub HD plug. Pin assignment see Chapter 5.3 Connector pin assignment, Page 5-7 .	Without heater	3 m (9.84 ft)	CLV490 to CDB420
2033126	Connector cover, one connection cable with 15-pin D Sub HD plug, one power supply cable with open end. Suitable for track chain use. Pin assignment see Chapter 5.3 Connector pin assignment, Page 5-7 .	Without heater	10 m (32.8 ft)	CLV490 to CDB420
2033127	as 2033126, but with longer cables	Without heater	10 m (32.8 ft)	CLV490 to CDB420
2020307	Connector cover, two connection cables with 15-pin D Sub HD connections (1 x plug/1x socket). Pin assignment see Chapter 5.3 Connector pin assignment, Page 5-7 .	Without heater	3 m (9.84 ft)	CLV490 to CDM490
2020981	Connector cover, two connection cables with open ends. Pin assignment see Chapter 5.3 Connector pin assignment, Page 5-7 .	Without heater	3 m (9.84 ft)	CLV490 to non-Sick Power pack, free wiring
2030065	Connector cover, two connection cables with 15-pin D Sub HD connections (1 x plug/1x socket) and one power supply cable with open end. Suitable for track chain use. Pin assignment see Chapter 5.3 Connector pin assignment, Page 5-7 .	With heater	3 m (9.84 ft)	CLV490 to CDM490
2031 034	as 2030065, but with longer cables	With heater	10 m (32.8 ft)	CLV490 to CDM490

Table 10-4: Types of the external parameter memory in the connector cover

10.3.1 Function of the external parameter memory

When it is started, the CLV490 is initialized with the data stored in its internal parameter set (EEPROM). If this parameter set has been copied to an external memory, the device can be replaced easily. The replacement device, therefore, does not have to be configured manually. Instead, it accesses the external parameter memory automatically (assuming that the correct start option has been selected). It then imports the parameter set to its RAM. This option ("Start with external parameters...") is set by default. The "Device Ready" and "Read Result" LEDs indicate whether the external memory was accessed successfully. The CLV490 also outputs messages for troubleshooting purposes on the auxiliary interface.

Note If the CLV490 and an external parameter memory in the connector cover are connected together to a **CDB420 or CDM490 Connection Module** containing also an external parameter memory provided by the **CMC400**, the CLV490 will detect both external parameter memories. Before starting the reading mode, the CLV490 will operate as follows:

- If the memory of the CMC400 comprises a **parameter set compatible with the CLV490**, the CLV490 loads this parameter set into the RAM and into its internal EEPROM. The "Device Ready" LED of the CLV490 blinks 20 times and then lights up constantly. Then the CLV490 clears the parameter memory in the connector cover. In CLV-Setup, the external parameter memory in the connector cover is no longer available.
- If the memory of the CMC400 comprises a **parameter set not compatible with the CLV490**, the CLV490 loads the internal parameter set from its internal EEPROM into the RAM. The CLV490 clears the parameter memory in the connector cover. In CLV-Setup, the external parameter memory in the connector cover is no longer available.
- If the memory of the **CMC400 is empty**, the CLV490 copies the internal parameter set from its EEPROM via the RAM to the CMC400 if write protection is disabled ("Write Protection" switch of the CMC400 in top position). The "Device Ready" of the CLV490 blinks 20 times alternately with the "Read Result" LED, then the "Device Ready" LED lights up constantly.

If write protection for the CMC400 is enabled, the CLV490 loads the internal parameter set from its internal EEPROM into the RAM. The "Device Ready" and "Read Result" blink constantly together. In both cases, the CLV490 clears the parameter memory in the connector cover.

In CLV-Setup, the external parameter memory in the connector cover is no longer available.

The CLV490 supports the CMC400 from firmware V 3.30 on.

If necessary, the memory of the CMC400 can be manually deleted.

To do so using CLV-Setup, choose CLEAR CMC400 under CLV490 in the menu bar.



The application of the CMC400, the changed function of the "Device Ready" and "Read Result" LEDs of the CLV490 as well as the remedy for error messages describes the *CMC400 Operating Instructions* (order no. 8010002, German/English).

10.3.2 Installation and electrical connection

The pin assignments/wire colors for the connection cables of the parameter memory are shown in the following tables:

- Parameter memory no. 2030023: [Table 5-5, Page 5-8](#)
 - Parameter memory no. 2020307: [Table 5-6 and Table 5-7, Page 5-9](#)
 - Parameter memory no. 2033126/no. 2033127: [Table 5-8 and Table 5-9, Page 5-10](#)
 - Parameter memory no. 2030065/no. 2031034: [Table 5-10 and Table 5-11, Page 5-11](#)
 - Parameter memory no. 2020981: [Table 5-15 and Table 5-16, Page 5-14](#)
 - Parameter memory no. 2021267: [Table 5-17 and Table 5-18, Page 5-15](#)
- Mount the parameter memory on the CLV490 as shown in [Chapter 5.5.3 Connecting the supply voltage, Page 5-18](#) and connect the cables to the CBD420 or CDM490 Connection Module or to the non-SICK power supply.

10.3.3 Operation

The parameter memory in the connector cover connected to the CLV490 is accessed

- using the selected CLV490 start option
- after the parameters have been downloaded to the CLV490 with the permanent storage function and the START WITH EXTERNAL PARAMETERS option

The start option is set at the bottom right of the DEVICE CONFIGURATION tab as shown in [Fig. 10-32](#) (grey frame). The START WITH EXTERNAL PARAMETERS option is selected by default.

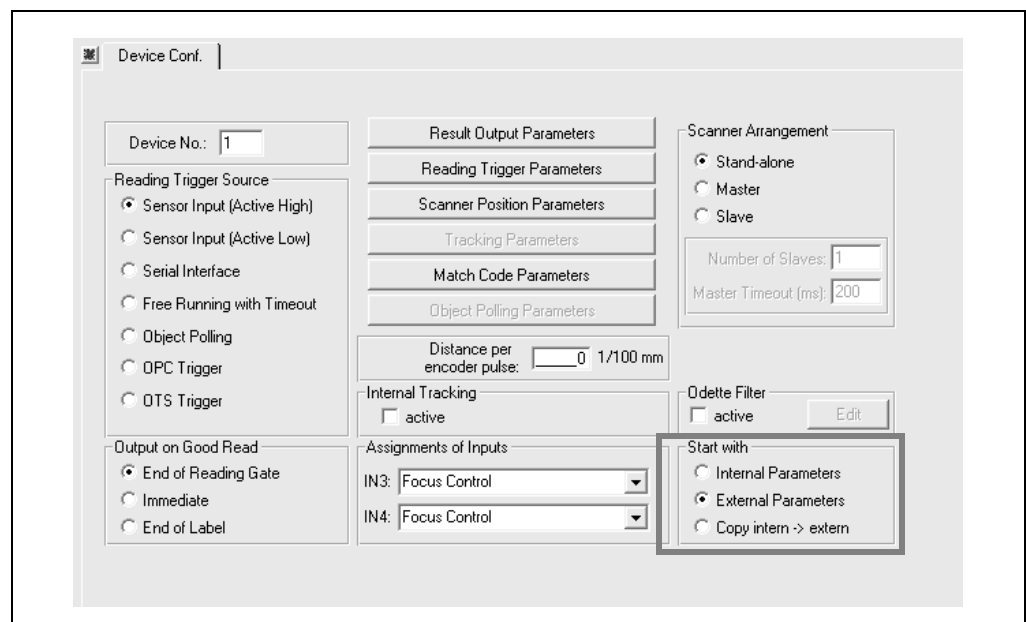

Fig. 10-33: CLV-Setup: "Device configuration" tab with the CLV490 start options

Start with internal parameters

When it starts, the CLV490 loads the internal parameter set to its RAM.

The "Device Ready" LED lights up constantly.

Since the data is stored permanently, it is not lost when the device is switched off.

Start with external parameters (default setting)

When it starts, the CLV490 loads the external parameter set to its RAM. The "Device Ready" LED blinks for approx. 10 s and then lights up constantly. The data in the CLV490 is lost when the device is switched off.

Start with copy internal -> external

When it starts, the CLV490 loads the internal parameter set to its RAM. It then copies the parameter set to the external memory in the connector cover and resets the start option to "Start with External Parameters".

The two "Device Ready" and "Read Result" LEDs blink alternately for approx. 10 s. The "Device Ready" LED then lights up constantly.

The data is not lost when the device is switched off since it is stored permanently in the CLV490 and is identical to the internal parameter set.

10.3.4 Switching on the device for the first time

Since the external parameter memory in the connector cover is empty (e. g. on delivery) after the CLV has started, the CLV copies its current parameter set to the external parameter memory if no CMC400 parameter memory module is available in the CDB420 or CDM490 Connection Module. Then the "Device Ready" LED lights up. The CLV490 is ready for operation.

If an external parameter memory containing a corresponding parameter set is connected to the CLV490, the "Device Ready" LED blinks for 10 s when the device starts up correctly and then lights up constantly.

10.3.5 Adjusting the parameter set in the external parameter memory (connector cover) after it has been downloaded to the CLV490

If the CLV490 is started with the START WITH EXTERNAL PARAMETERS option with an external parameter memory in the connector cover and if the parameter set is downloaded from CLV-Setup to the CLV490 with the **permanent** storage option, CLV-Setup asks you whether the new parameter set is also to be copied to the external parameter memory ([Fig. 10-34](#), [Page 10-38](#)). This function prevents the CLV490 from reloading the old parameter set the next time it starts.

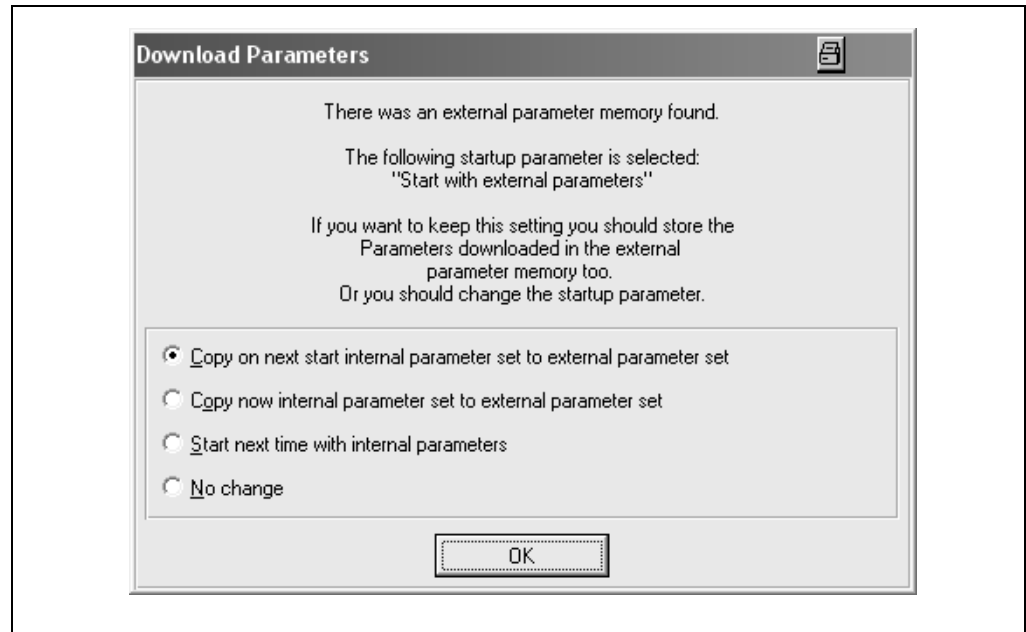

Fig. 10-34: CLV-Setup: dialog box for adjusting the external parameter memory

- Adjust the parameter set in the external parameter memory as described in [Chapter 6.4.1 Configuring the CLV490 via the user interface of CLV-Setup, Page 6-5](#).

10.3.6 Meaning of the LEDs

The function of the two "Device Ready" and "Read Result" LEDs, as defined by the selected start option, is shown in [Table 3-3, Page 3-12](#). Their function in the event of an error accessing the external memory in the connector cover as well as troubleshooting measures are described in [Table 8-2, Page 8-3](#).

10.3.7 Error messages

If errors occur accessing the external parameter memory in the connector cover, the CLV490 outputs error messages on the auxiliary interface. When the CLV490 is **started**, these messages can be displayed using the "CLV-Setup" program.

1. Connect the PC to the auxiliary interface on the CLV490 using a 3-core RS 232 data cable (null modem cable) (CDB420 or CDM490: connect the PC to the internal 9-pin "Aux" plug). See [Chapter 5.5.6 Connecting the PC, Page 5-21](#).
2. Switch on the PC and start Windows.
3. Start the "CLV-Setup" program and open the Terminal Emulator.
4. Switch on the power supply for the CDB420 or CDM490.
The CLV490 starts and loads the parameter set from the external memory.
5. Monitor the messages in the Terminal Emulator.

[Table 8-3, Page 8-5](#) lists the error messages with the appropriate troubleshooting measures.

10.3.8 Replacing a CLV490

The device is replaced by starting the new CLV490 with the START WITH EXTERNAL PARAMETERS option (default). This is the case when the device is put into service for the first time, e. g. when it is taken from the warehouse. The device must be replaced with a device of the same type. You do not need to connect a PC to replace the device.

- Replace the device as described in [Chapter 10.12.2 Importing the parameter set from the external memory, Page 10-74](#).

The CLV490 imports the external parameter set into the RAM. This is sufficient to ensure that the device operates correctly. If the parameter set is to be stored permanently in the CLV490 (EEPROM), a PC with the "CLV-Setup" program must be connected to upload the parameter set from the CLV490 to CLV-Setup and then download it again to the CLV490 with the PERMANENT storage option. When asked to do so, adjust the external memory again.

10.4 Optional heating

10.4.1 Features

- Integrated heater (permanently installed)
- Wider range of applications for CLV490: up to max. -35 °C (-31 °F)
- Supply voltage 24 V DC $+20\%$ / -10%
- CLV490 enabled via internal temperature switch (power-up delay approx. 35 to 40 min. at 24 V DC and min. ambient temperature of -35 °C (-31 °F))
- Required cable cross-section (power supply): min. 0.75 mm^2 (approx. 20 AWG)

10.4.2 Design

The heating system comprises two parts:

- the front window heater
- the housing heater

The optional heating system is installed and tested at the factory. The user cannot install it on site.

10.4.3 Function

When the 24 V DC supply voltage is applied, a temperature switch first supplies electric current to the heater only. This switch enables the supply voltage for the CLV490 when the internal temperature rises above 7 °C ($+44.6\text{ °F}$) during the warm-up phase (approx. 35 min). The device then performs a self-test and switches to Reading mode. The "Device Ready" LED lights up to indicate that the device is ready.

When the internal temperature has reached approx. 25 °C ($+77\text{ °F}$), a further temperature switch deactivates the housing heater and reactivates it if necessary. Reading mode is not interrupted as a result. The front window heater remains active constantly. The temperature curve inside the housing is shown in [Fig. 10-35](#).

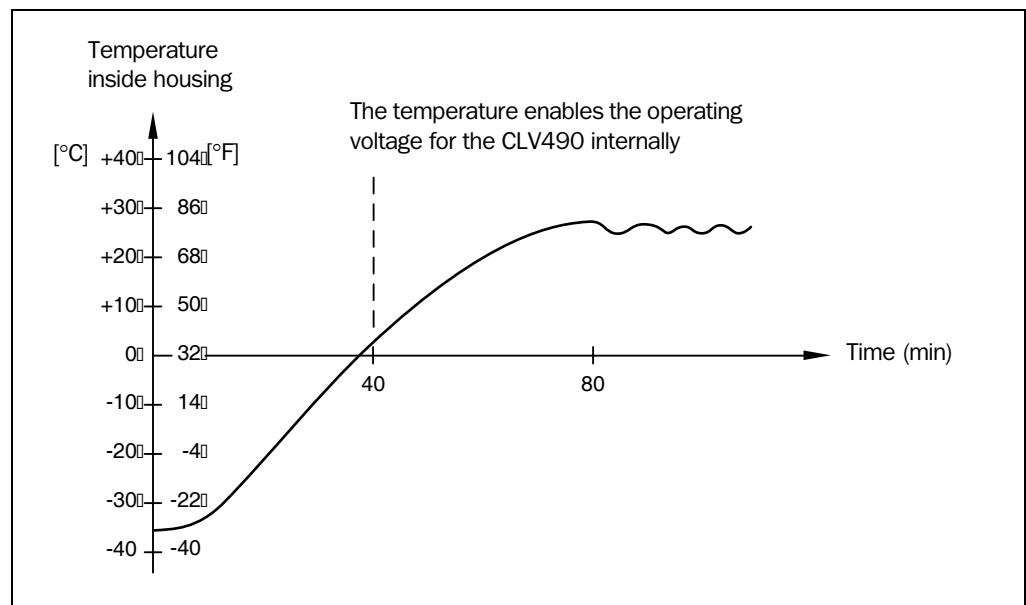

Fig. 10-35: CLV490 with heater: temperature curve inside the housing

10.4.4 Electrical installation

Cable cross-section

The connection cables for the power supply must have a cross-section of at least 0.75 mm² (approx. 20 AWG).

See also [Chapter 5.4.2 Supply voltage, Page 5-16](#).

Power consumption

The power consumption depends on the variant:

- Line scanner with heater: typically 75 W and max. 90 W
- Line scanner with oscillating mirror and heater: typically 75 W and max. 100 W

These values apply to operation without the switching outputs connected.

CDB420 or CDM490 Connection Modules

The CDB420 or CDM490 Connection Modules are suitable to power the CLV490 with heater. An external power supply pack with a higher power output must be used to provide the required voltage of 24 V DC +20%/–10%. The incoming/outgoing cables must be protected by corresponding fuses. The optional CMP490 Power Supply Module is not suitable for CLVs with heater.

See [Chapter 3.1.3 System requirements for stand-alone configuration, Page 3-2](#).



For connecting the CLV490 with heater to the CDB420 or CDM490 see also the "CDB420 Connection Module" *Operating Instructions* (order no. 8010001, German/English) respectively the "CDM490 Connection Module" *Operating Instructions* (order no. 8010005, German/English).

10.4.5 Outdoor applications

If the CLV490 with integrated heater is used outdoors, it should be installed in a protective housing to prevent the front window from being damaged by rain, snow, or dust. The housing also acts as a wind protector.

10.5 System messages

The CLV490 outputs all system messages in plain text on the auxiliary interface. The messages are in English and can be displayed in the Terminal Emulator in the "CLV-Setup" program.

See also [Chapter 6.6.1 Displaying messages, Page 6-59](#).

10.5.1 CLV490 without external parameter memory

Message	Meaning
"CLV490 Soft.Vers. Vx.xx Aend. Nr. 0000 CLV490/OTS"	The software version and revision is displayed when the power supply is switched on.
"internal parameters loaded"	When the CLV490 is started, it imports the parameter set that was last stored permanently in the internal EEPROM to the RAM
"laser safety timeout"	The CLV490 has shut off the laser diode 10 minutes (default setting) after a reading pulse has begun. The reading interval is still active, even though the CLV490 is no longer reading. The reading interval has to be terminated by a corresponding pulse signal. The laser diode is activated again with the next reading pulse.
"no code"	In Reading/Percentage Evaluation mode, the CLV490 indicates that no codes matching the parameterized evaluation conditions were detected during the reading interval (error status ST = 2 output on the host interface).
"No ext. parameter memory connected"	No external parameter memory was connected to the CLV490 when it was started.

Table 10-5: CLV490 system messages

10.5.2 CLV490 with external parameter memory connected

In addition to the messages above, the CLV490 also indicates whether it was able to access the external parameter memory

Message	Meaning
"diff. SW version of parameters"	When the CLV490 was started, the software version of the parameter set in the external memory was different from that in the CLV490. The parameter set is still transferred.
"external parameters loaded"	When the CLV490 was started, the external parameter set was imported successfully to the RAM.
"internal parameters copied to external memory"	When the CLV490 was started, the internal parameter set was successfully copied to the external parameter memory.

Table 10-6: Additional CLV490 system messages for the connected parameter memory

10.6 Installing and operating the "CLV-Setup" program



The scope of delivery of the CLV490 includes a CD-ROM ("Manuals & Software") containing the "CLV-Setup" program. The software can be installed on a PC with the following minimum configuration: Pentium II processor, 350 MHz, and 64 MB RAM, CD drive, serial interface and mouse (recommended) as well as an operating system Windows 95™/98™, Windows NT™, Windows 2000™ or Windows XP™.

Approximately 25 MB of hard disk space is required to install CLV-Setup (V 4.10) and CLV Assistant, approximately 20 MB to install CLV-Setup Help (V 4.10).

Note For the latest version of the software, see www.sick.com.

10.6.1 Preparations

1. Make sure you have the CD-ROM ("Manuals & Software") at hand.
2. Connect the CLV490 to the CDB420 or CDM490 Connection Module (see [Chapter 5.5.3 Connecting the supply voltage, Page 5-18](#)).
3. Connect the PC to the auxiliary interface on the CLV490 using a 3-core RS 232 data cable (null modem cable) (CDB420 or CDM490: connect the PC to the internal 9-pin "Aux" plug). See [Chapter 5.5.6 Connecting the PC, Page 5-21](#).
4. Switch on the power supply to the CDB420 or CDM490.
Once the CLV490 has started, the "Device Ready" LED lights up.
5. Switch on the PC and start Windows.

10.6.2 Installing the software

The "CLV-Setup" installation program creates a directory "CLV490", a series of subdirectories, and the necessary links. A deinstaller is also installed automatically so that you can remove the program from the PC at any time. As of version V 2.6, CLV-Setup will only be available and further developed as a 32-bit application.

Note The following instructions describe how to install the software on Windows XP™. These instructions may differ depending on the operating system you are using (for example, administrator rights are required to install the software on Windows XP).

Initial installation

User software CLV-Setup:

1. Shut down all the applications running in Windows.
2. Insert the CD-ROM into the CD-ROM drive.
3. If the auto run function is enabled, the start page (table of contents) of the CD-ROM is automatically displayed in your browser.
4. Select the SOFTWARE folder on top left.
5. Select CLV, ICR, OPS SETUP SOFTWARE in the listing.
A table with CLV-Setup information is displayed.
6. Select DOWNLOAD under SOFTWARE FILE.
7. In the FILE DOWNLOAD dialog box select the option to install directly from the CD-ROM. Confirm with OK. The software is automatically saved in the "Programs\CLV" directory on your hard disk.

– or –

Select the option to save the software locally on your local hard disk and confirm with OK.

In the FILE DOWNLOAD dialog box select the desired target directory on your hard disk. The "CLVSetupxx.exe" file is then saved at this location (xx = version number). Select OPEN in the dialog box to start the file.

8. The installation program starts and guides you through the installation with screen messages. The program asks you for your user name and company name. This information appears as a header in printouts. "CLV-Setup" and CLV Assistant are installed. The software will be entered in the Windows start menu under "Programs\CLV-Setup".
9. Please read the Readme file, as it contains the latest information and problems regarding CLV-Setup.
10. Then confirm the final installation message by clicking "OK".

CLV-Setup Help (Online):

1. Return to the start page of the CD-ROM with the opened folder "Software".
2. Select CLV, CLV HELP SOFTWARE in the listing.
A table with CLV Help information is displayed.
3. Select DOWNLOAD under SOFTWARE FILE.
4. In the FILE DOWNLOAD dialog box select the option to install directly from the CD-ROM. Confirm with OK. The software is automatically saved in the "Programs\CLV" directory on your hard disk.

– or –

Select the option to save the software locally on your local hard disk and confirm with OK.

In the FILE DOWNLOAD dialog box select the same target directory as selected for CLV-Setup on your hard disk.

The "CLVHelp.exe" file is then saved at this location.

5. After downloading the software, select OPEN in the dialog box to start the software. The software is installed in the sub directory "Help" of the main directory "CLV". CLV Help will also be entered in the Windows start menu under "Programs\CLV-Setup".
- Restart the PC.
The Windows DLL files are possibly updated.

The "CLV-Setup" program, the CLV Assistant and the online "CLV-Setup Help" are installed and ready.

The program logs all of the files that are installed to the "install.log" file. This list is used by the uninstaller to remove CLV-Setup and must not be deleted if you want to use the uninstaller at some time in the future.

Updating the program

There are two ways of installing a new version of CLV-Setup:

- You can install the new version and still keep the old version (parallel installation)
- or –**
- You can install the new version over the old version (overwrite)

Installing the new version while still keeping the old one:

If you want to install the new version and still keep the old version of CLV-Setup, follow the procedure described under *Initial installation*. When the program asks you for the target directory, you must specify a **new directory**. Both versions of the software are then available but must not be started simultaneously.

The configuration files "*.scl" (scanner configuration), "*.npj" (network project), "*.opj" (OTS project) or "*.rpj" (redundant OTS project) of the old version can be used in the new version and contain the CLV490 parameter sets as well as project data if several scanners had been organized logically by projects. In order to do so, copy the configuration files from the "data" directory of the old version to the "data" directory of the new version.

Installing the new version over the old one:

Before you can install the new version of the software, you must remove the files of the old version – with the exception of the configuration files "*.scl" (scanner configuration), "*.npj" (network project), "*.opj" (OTS project) or "*.rpj" (redundant OTS project). They contain the CLV490 parameter sets as well as project data if several scanners had been organized logically by projects.

The deinstaller of the old version removes the program files. You can use the deinstaller to remove all of the files (with the exception of the configuration files) or only selected files. The default setting is a complete deinstallation (the configuration files are not deleted). With the custom deinstallation, the files are listed and only selected files are deinstalled. If you choose this deinstallation method, make sure that the main directory containing the configuration files "*.scl" is not deleted. We recommend that you move these files to a different directory and copy them back to the "data" directory later.

1. From the Windows Start menu, choose PROGRAMS and the deinstaller for CLV-Setup. The deinstaller starts and guides you step by step through the deinstallation procedure.
2. Choose the deinstallation method (complete or custom).
3. Install the new version of CLV-Setup as described under *Initial installation*, making sure to choose the same directory.

The new version of CLV-Setup is installed. The configuration files of the old version can be used again.

10.6.3 Starting CLV-Setup

The "CLV-Setup" program is launched with the following default settings:

Communication	COM 1, 9,600 bd, 8 data bits, 1 stop bit, no parity
Transmit control character	Start: STX, Stop: ETX
Receive control character	Start: STX, Stop: ETX
Unit of measure	Metric (depending on the selected installation)
Browser	User dependent
Language	As selected for the installation
Company name	As entered for the installation
User name	As entered for the installation
Automatic connection to CLV490	On startup: yes On scanner selection: yes When the Terminal Emulator is started/closed: yes
Initial screen	Yes
Storage confirmation prompt	Yes
Last type selected	CLV41x
File storage location	"data" (configuration files for CLV490)

Table 10-7: Default settings in CLV-Setup

1. Switch on the PC and start Windows.
2. Choose CLV-SETUP from the Start menu.
The SICK logo is then followed by the initial screen.
3. Confirm the initial screen.
CLV-Setup then checks whether a CLV490 is connected to the **COM 1** port on the PC (default setting in CLV-Setup) and whether the communication parameters on the PC match those on the CLV490. If this is the case, the CONNECTED status is displayed with the CLV490 specification in the status bar right in the bottom of the screen. The CLV490 type (here: CLV490) is displayed in the DEVICE drop-down list in the top right of the toolbar.

The program then loads the internal description of the CLV490 as well as the default parameter values and displays them on the tabs. Finally, CLV-Setup uploads the current parameter set from the RAM of the CLV490 and displays the values on the tabs instead of the default values.

You can edit the current parameter set on the tabs. The default values are displayed when the device is used for the first time.

Troubleshooting

If the program cannot establish communication, it outputs a timeout warning and displays No CONNECTION in the status field. This may be because the CLV490 is not connected or because the communication parameters on the CLV490 do not match those on the PC. In this case, CLV-Setup enters the CLV490 type of the device it last communicated with in the DEVICE field on the toolbar. The default setting the first time the device is used is the CLV41x. The software then loads the internal device description for this CLV490 type and displays the default values on the tabs.

1. Connect the PC to the auxiliary interface on the CLV490 using a 3-core RS 232 data cable (null modem cable) (CDB420 or CDM490: connect the PC to the internal 9-pin "Aux" plug). See [Chapter 5.5.6 Connecting the PC, Page 5-21](#).
2. Click  (AutoBaud detect) in the toolbar or choose OPTIONS, AUTOBAUD DETECT. CLV-Setup scans the serial interface by varying the communication parameters and sends a telegram to the CLV490 repeatedly. As soon as a response is registered from the CLV490, CLV-Setup signals the detected communication parameters. [Fig. 10-36](#) shows an example of the results of the AutoBaud detect function. The CONNECTED status is displayed right in the status bar in the bottom of the screen.
3. Confirm the AUTO DETECT dialog box with OK. CLV-Setup displays the detected CLV490 type in a separate dialog box and asks you whether you want to upload the current parameter set from the CLV490.
4. Confirm the dialog box with Yes. CLV-Setup uploads the current parameter set from the RAM of the CLV490 to its database and displays the values on the tabs.

You can edit the current parameter set on the tabs.

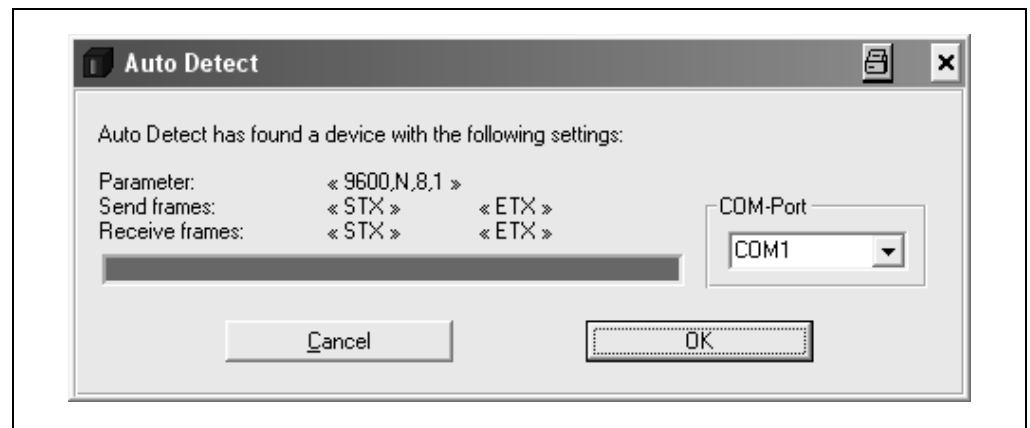



Fig. 10-36: CLV-Setup: Result display of the AutoBaud Detect function

– or –

2. Choose OPTIONS, SERIAL INTERFACE from the menu bar. CLV-Setup displays the current communication parameter settings on the PC in the COM PARAMETERS dialog box.
3. Make sure that the communication parameters on the PC and CLV490 are identical (**connected COM port, 9,600 bd, 8 data bits, 1 stop bit, no parity**)
4. Confirm the dialog box with OK. CLV-Setup attempts to communicate with the CLV490 again. If it is successful, it displays the CONNECTED status right in the status bar in the bottom of the screen.
5. Click  in the toolbar. CLV-Setup then uploads the current parameter set from the RAM of the CLV490 to its database and displays the values on the tabs.

You can edit the current parameter set on the tabs.

10.6.4 User interface

The graphical user interface (GUI) of the CLV-Setup is largely self explanatory. The online CLV-Setup Help function provides a description of how to use the program under HELP TO CLV-SETUP in the help navigation tree. The GUI is shown in [Fig. 10-37](#).

The program window of the GUI comprises the following elements:

- Title bar that displays the program name, current configuration file, and its status (e. g. "No File")
- Menu bar with pull-down menus
- Toolbar with buttons for triggering various functions
- Drop-down list (top right) for selecting the device type
- Frame for displaying the navigation tree of the tabs (on left-hand side)
- Frame for displaying the tabs for CLV490 (Reading Configuration, Device Configuration, etc.) (on right-hand side). The numbers of displayed tabs depends on the selected items in the navigation tree on the left side. The parameters on the tabs are grouped according to their function. Some of these parameters open further dialog boxes
- Status bar (bottom) with two display fields for the communication between CLV-Setup and the CLV490, the PC's interface parameter display, error display field (system errors), device specification field and status display for the connection to the CLV490.

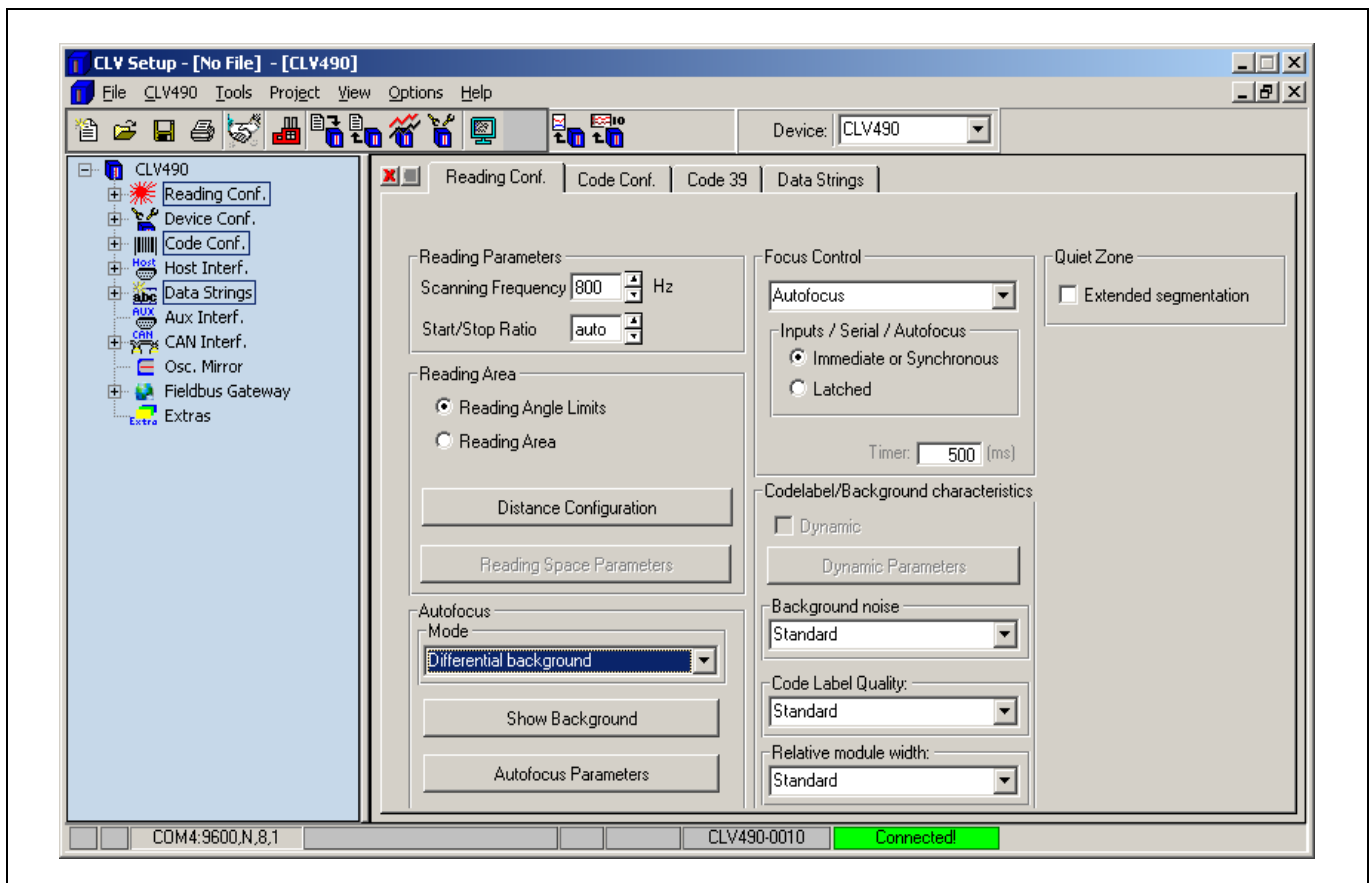

Fig. 10-37: User interface of the "CLV-Setup" software

10.6.5 Functions

The "CLV-Setup" program (from version V 4.0) features the following functions to carry out:

- Uploading the default parameter set from the database of CLV-Setup
- Automatic communication attempt with the CLV490 when the program is started
- Automatic software compatibility check in the CLV490
- Uploading and displaying parameter set stored in the CLV490
- Changing the parameter/parameter values on the tabs
- Downloading the changes to the parameter set in the CLV490
- Saving the changes to the parameter set as a configuration file "*.scl"
- CLV Assistant for simplified parameterization (not for CLV490)
- Printing the configuration files
- Exporting the configuration files in RTF format
- Exporting the command strings contained in the profile bar codes in ASCII format
- Printing the parameter set in the form of profile bar codes (not for CLV490)
- Online access to the CLV490 via a Terminal Emulator (select operating mode, start operating functions, log file for communication between the CLV490 and CLV-Setup, extended Terminal mode, e. g. for displaying CLV490 messages)
- AutoBaud Detect for automatic communication setup with the CLV490
- Selecting the COM port of the PC for adapting the data transfer parameters
- Monitoring the data communication of the CLV host interface
- Selecting language setting
- Selecting units of measure
- Displaying the last 10 configuration files that were processed
- Saving the CLV490 type that was selected last
- Automatic storage confirmation prompt when changes are made to the configuration file
- Wizards for individual functions
- Clearing the optional CMC400 parameter memory in the CDB/CDM Connection Module
- CLV490 only: Alignment check to calculate the required setting for angles
- CLV490 only: Background analysis
- CLV490 only: I/O monitoring
- Setting switches for starting the program (in the "CLVmain.ini" file)
- Hot keys [F keys] for important functions (using the program without a mouse)
- Starting program with SCL file as argument
- Macro player for recording and playing a macro file
- Context-sensitive help via the [F1] key

10.6.6 Hot keys

- [F1] Start "CLV-Setup Help" online
- [F2] Open dialog box to execute device functions
- [F3] Upload complete set of parameters from CLV490
- [F4] Download complete set of parameters to CLV490
- [F5] Open configuration file
- [F6] Save configuration file

- [F7] Load default setting of CLV490 from CLV-Setup database
- [F8] Start AutoBaud Detect
- [F9] Load operating data from CLV490 to be displayed and reset
- [F10] Open Terminal Emulator

10.6.7 Opening and closing tabs

After starting the user interface, CLV-Setup displays those tabs in the frame on right-hand side whose names are framed in the navigation tree on left-hand side. The first tab covers the other tabs in the sequence but their marks are still visible on the top of the tabs. If you click some buttons on a tab in the fore-ground, several sub dialogs will also be opened as tabs and added to the first tab. In the frame, all tabs on the right will then be shifted more to the right side.

To scroll the tabs, use the sliding control elements at the left corner on top of the frame which are displayed by CLV-Setup.

You can open and close the tabs in the following way:

In the navigation tree:

- Opening:
Double-click the desired entry or put the mouse cursor on the entry and select "Show dialog" in the context menu using the right mouse button.
To display several entries under a branch, click the corresponding "+" symbol.
To hide displayed sub entries, click the corresponding "-" symbol.
- Closing:
Put the mouse cursor on the desired entry and select "Hide dialog" in the context menu using the right mouse button.

In the frame for displaying tabs:

- Opening:
Click on the desired mark on the top of the tab. If necessary, scroll the tabs.
- Closing:
To close the tab in the fore-ground, click on the red cross at the left corner on the top.

Pressing the left mouse button, the left frame with the navigation tree can be move from the program window to a separate position on the screen. If the navigation tree has been closed, it can be reopened using the VIEW menu.



10.6.8 Online help – CLV-Setup Help

The procedure for setting the CLV490 parameters is supported by the online help function, which is displayed in an HTML browser, such as Internet Explorer™. You can call up context-sensitive help on each parameter as well as a description of its function.

1. Press the [F1] key.
The browser is launched automatically and displays the help topic.
2. If the program cannot find a browser, it asks you to specify the storage location on the hard disk.
Enter the name of the executable file and the path in the dialog box.
3. Use the [ALT]+[TAB] keys to switch between the CLV-Setup and CLV-Setup Help applications and prevent several browser windows from being opened.
4. To display an overview of the Help function, Choose HELP, CONTENTS from the CLV-Setup menu bar.

5. In the left-hand frame click on the desired entry in the navigation tree. CLV-Setup Help then displays the associated help text in the right-hand frame and jumps to the parameter heading.

10.6.9 Transferring parameter sets between CLV-Setup and the CLV490

See [Chapter 6.4.1 Configuring the CLV490 via the user interface of CLV-Setup, Page 6-5](#).

10.6.10 Unknown parameters





Uploading from the CLV490

If CLV-Setup does not recognize certain parameters or parameter values when it uploads them from the CLV490, it outputs a warning. This may be due to the fact that the CLV490 is a special model or because the version of CLV-Setup is older than the version on the CLV490. CLV-Setup displays the unknown parameters in the window on the EXTRAS tab. The parameters are displayed in the form of command strings and can be edited using the command string conventions. In this way, upward compatibility with the CLV490 is ensured. When the parameter set is saved as a configuration file in CLV-Setup, these parameters are also included and are also downloaded to the CLV490.

Downloading to the CLV490

If the CLV490 does not accept individual parameters or parameter values in the parameter set downloaded with CLV-Setup, it outputs a separate warning for each parameter on the screen. This could be due to the fact that the version of the "CLV-Setup" software is newer than the software version on the CLV490 and therefore contains new parameters and parameter values that are not implemented in the older software version.

We recommend that you check the effects of warnings in the CLV490 as follows:

1. Check whether the CLV490 functions correctly after the parameter set is downloaded.
2. Click  in the toolbar.
CLV-Setup loads the default settings from the database.
3. Click  in the toolbar.
CLV-Setup uploads the problem parameter set from the CLV490.
4. Click  in the toolbar.
CLV-Setup prints out the problem parameter set when you confirm the dialog box.
5. Open the previous configuration file "*.scl" for the CLV490.
6. Click  in the toolbar.
CLV-Setup prints out the parameter set used up to now when you confirm the dialog box.
7. Compare the two parameter sets.
To restore the previous status, correct individual parameters in the problem parameter set if necessary and download them to the CLV490 again.

Opening configuration files "*.scl"

Every time it loads configuration files, CLV-Setup checks whether it recognizes all the parameters/values.

If the program detects an error, it outputs a warning and enters the problem parameter/value in the window on the EXTRAS tab.

10.6.11 Log file in the Terminal Emulator

The Terminal Emulator can log the communication between CLV-Setup and the CLV490. CLV-Setup stores the data transmitted in both directions with the following identifiers:

--> PC: CLV490 sending to CLV-Setup

PC --> CLV490 receiving from CLV-Setup

1. Click  in the toolbar.
The Terminal Emulator window opens.
2. Click the empty checkbox in front of the WRITE LOGFILE option on the right.
The SAVE LOGFILE AS ... dialog box opens.
3. Enter a file name with the extension ".log" and exit the window by choosing SAVE.
CLV-Setup saves the file in the "data" directory and records an entry in the log file.
4. To deactivate the log function, click the checkbox in front of the WRITE LOGFILE option again or close the Terminal Emulator window.

10.6.12 Starting CLV-Setup with an "INI file" as an argument

When the program is started, CLV-Setup can also be transferred the name of an "INI file" as a parameter. To do so, enter "/INI" in front of the file.

Example:

```
"CLVmain32.exe\data\Set1_CLV490.scl /INI user.ini "
```

CLV-Setup is launched with the initialization data contained in the "user.ini" file and loads the configuration file "Set1_CLV490.scl" from the "data" directory straight away.

The "user.ini" file must be stored in the same directory as "CLVmain32.exe".

You can use this method to link CLV-Setup to several different configurations on your Windows desktop.

In this way, for example, you can prevent CLV-Setup from attempting to establish a connection when a CLV490 is not connected.

10.6.13 The CLV Assistant

The CLV assistant is not suitable for parameterizing the CLV490.

10.7 Configuring a CLV490 with command strings

The CLV490 can be parameterized and operated with command strings via the auxiliary interface or the host interface. Parameters which are unknown to the CLV-Setup may be used providing that the command string convention is followed. This allows, among other things, the setting of special devices as well as the configuration of new CLV490 parameters (which are unknown to "CLV-Setup" program) if your version of the CLV490 is older in comparison. The "CLV-Setup" user interface is based on the command language.

The command language accesses the CLV490's command interpreter directly. Use this language with care. Commands sent to the CLV490 are carried out immediately.

Parameter values changed by commands are at first only activated in the current parameter set in the CLV490's RAM. The altered parameter values must be saved to non-volatile memory in the EEPROM (after the changes are made) using a special command. If the values are not saved, they will be lost when the voltage supply is cut off.



The "CLV-Setup" Terminal Emulator's online mode makes it possible to parameterize the CLV490 with command strings directly. Fig. 10-38 shows a view of the Terminal Emulator with command lines and PC/CLV490 communication output windows.

1. Click on  in the symbol bar.
The Terminal Emulator window opens. The CLV490 is in Reading mode.

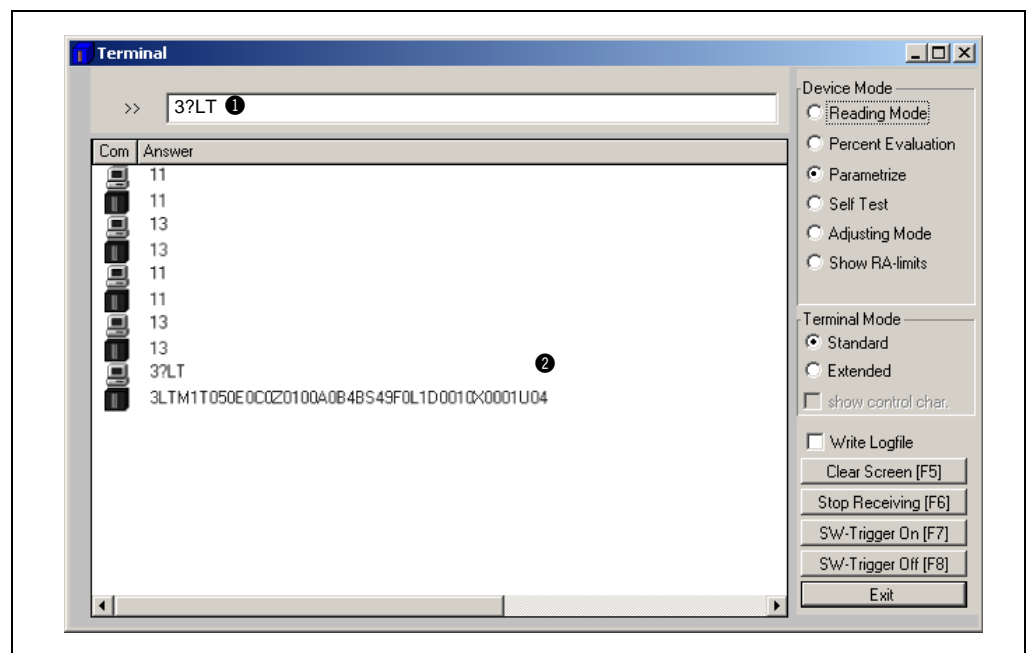

Fig. 10-38: CLV-Setup: entering commands in the Terminal Emulator

2. Under DEVICE MODE, click on the PARAMETERIZING option field.
The CLV490 aborts reading mode. The "Device Ready" LED extinguishes. CLV-Setup switches the CLV490 into the parameterize mode with a command. All commands in parameterize mode begin with "3".
3. Enter the desired command in command line ①, and press the [Return] key.
The command is sent to the CLV490.
The CLV490 answers with an echo if the command was syntactically correct (in most cases).

Example:

The command "3?LT" causes the CLV490 to display the parameter values of the rea-

ding trigger in coded form in output window ②.

4. To return to Reading mode, click on the READING MODE option field.
The "Device Ready" LED lights up.

Note The parameter values directly changed with command strings in the CLV490 are registered and shown only after the parameter set is uploaded from the CLV490.

Outputting command strings for all the parameter settings

You can output a list of all the parameter settings configured with CLV-Setup in ASCII format. To do so, proceed as follows:

1. In the menu bar, choose EXPORT PARAMETERS under CLV490.
Starting from the default settings, CLV-Setup collects all the command strings required to parameterize the default configuration and customized settings.
The SELECT FILE NAME FOR PARAMETER EXPORT dialog box is displayed.
2. Enter a file name and click the SAVE button.
CLV-Setup saves the data as a text file in the directory shown.

You can open this text file using any Windows text editor.

If the commands are sent from the host/PLC to the CLV490 for configuration, note that "3 EEW" has to be sent as the last command to ensure that they are permanently transferred to the CLV490 (EEPROM).

10.8 Calculating parameter values for setting the CLV490

10.8.1 Calculating the number of scans (for standard decoder)

The maximum number of scans possible for a bar code depends on the conveyor velocity v .

Line scanner: ladder-type bar code arrangement

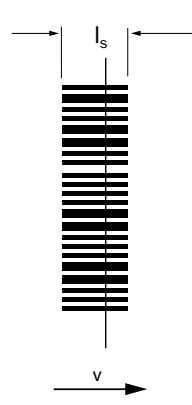

Specified values:
 Number of scans $n = ?$
 Conveyor velocity $v = 1.5 \text{ m/s}$
 Bar length $l_s = 20 \text{ mm (0.8 in)}$
 Scanning frequency $f = 600 \text{ Hz}$
 Bar code 100 % readable

Calculation for standard decoder!

$$v = \frac{s}{t}$$

$$v = \frac{l_s}{n \times t_{\text{scan}}}; \quad t_{\text{scan}} = \frac{1}{f}$$

$$v = \frac{l_s}{n} \times f$$

$$n = \frac{l_s}{v} \times f$$

$$n = \frac{0.02 \text{ m}}{1.5 \text{ m/s}} \times 600/\text{s} \quad \mathbf{n = 8}$$

Fig. 10-39: Line scanner: calculating the number of scans for ladder-type bar code arrangements

Line scanner: fence-type bar code arrangements

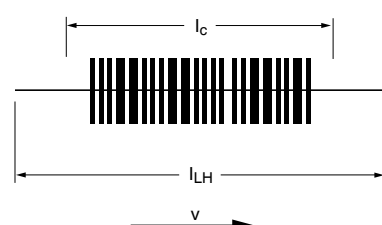

Specified values:
 Number of scans $n = ?$
 Conveyor velocity $v = 2 \text{ m/s}$
 Code length with blanc zone $l_c = 150 \text{ mm (5.9 in)}$
 Reading field height $l_{LH} = 400 \text{ mm (15.8 in)}$
 Scanning frequency $f = 600 \text{ Hz}$
 Bar code 100 % readable,
 all scans on the code
 Code window $s = l_{LH} - l_c$

Calculation for standard decoder!

$$v = \frac{s}{t}$$

$$v = \frac{(l_{LH} - l_c)}{n \times t_{\text{scan}}}; \quad t_{\text{scan}} = \frac{1}{f}$$

$$v = \frac{(l_{LH} - l_c)}{n} \times f$$

$$n = \frac{(l_{LH} - l_c)}{v} \times f$$

$$n = \frac{(0.4 - 0.15) \text{ m}}{2 \text{ m/s}} \times 600/\text{s} \quad \mathbf{n = 75}$$

Fig. 10-40: Line scanner: calculating the number of scans for fence-type bar code arrangements

Line scanner with oscillating mirror: fence-type bar code arrangement

Line scanner with oscillating mirror: side read on object

Calculation for standard decoder!

Specified values:
 Number of scans $n = ?$
 Conveyer velocity $v = 0.5 \text{ m/s}$
 Code length with blanc zone $l_c = 100 \text{ mm (3.9 in)}$
 Code length under $10^\circ_{CW} = \frac{100 \text{ mm}}{\cos 10} = 102 \text{ mm (4 in)}$
 Reading field height $l_{LH} = 500 \text{ mm (19.7 in)}$
 Scanning frequency $f = 600 \text{ Hz}$
 Bar code 100 % readable, all scans on the code
 Code windows $= l_{LH} - l_c$

1. Dwell time of the bar code in the reading area:

$$t = \frac{s}{v}$$

$$t = \frac{(l_{LH} - l_{CW})}{v}$$

$$t = \frac{(0.5 - 0.102)}{0.5 \text{ m/s}}$$

$t = 796 \text{ ms}$

2. Required oscillating mirror frequency:

$$f_{sw} = \frac{1}{t}$$

$$f_{sw} = \frac{1}{0.796 \text{ s}}$$

$f_{sw} = 1.26 \text{ Hz}$

3. Number of possible scans (rough estimate):

$$n = \frac{f}{f_{sw}}$$

$$n = \frac{600 \text{ Hz}}{1.26 \text{ Hz}}$$

$n = 476$

Fig. 10-41: Line scanner with oscillating mirror: calculating the number of scans for fence-type bar code positioning

10.8.2 Calculating the start position and mirror speed for the forward and return phase of the One-Shot function

Line scanner with oscillating mirror

Theoretical calculation: reading from the front (object moving towards CLV490)

Calculation for Standard decoder!

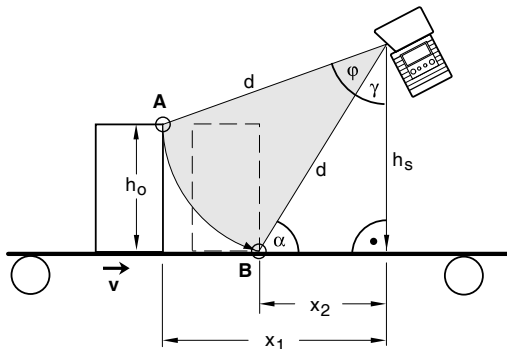

(Scanning direction is vertical to drawing plane)

Legend:

- h_0 = Max. object height
- h_s = Distance of the CLV across conveyor level
- φ = Oscillating angle
- α = Max. angle of impact on bar code (skew)
- Start Phase 1: Point A
- Start Phase 2: Point B

Specified values:

- $h_s > h_0$
- $\alpha \leq 45^\circ$ (better: $\alpha \leq 30^\circ$)
- Set max. deflection angle: $\pm 20^\circ$
- Determine distances through measurement:
 - x_1 = Distance at Start Phase 1
 - x_2 = Distance at Start Phase 2

1. Focus position for distance configuration:

$$\sin \alpha = \frac{h_s}{d} \Rightarrow d = \frac{h_s}{\sin \alpha}$$

2. Oscillating angle φ

$$\gamma = 90^\circ - \alpha$$

$$\cos(\varphi + \gamma) = \frac{(h_s - h_0)}{d}$$

$$\varphi = \arccos\left(\frac{(h_s - h_0)}{d}\right) - \gamma$$

- Enter φ symmetrically to CW = 50:

$$\text{StartPos 1} = 50 \text{ CW} + \left(\frac{\varphi}{2} \times \frac{1 \text{ CW}}{0,5^\circ}\right)$$

$$\text{StartPos 2} = 50 \text{ CW} - \left(\frac{\varphi}{2} \times \frac{1 \text{ CW}}{0,5^\circ}\right)$$

3. Mirror speed φ^* :

$$v = \frac{\Delta x}{\Delta t}; \Delta x = x_1 - x_2$$

$$\varphi^* = \frac{\Delta \varphi}{\Delta t}$$

During the period Δt , in which the object moves from x_1 to x_2 the oscillating mirror must also pass through the angle $\Delta \varphi$

$$\Rightarrow \frac{\Delta x}{v} = \frac{\Delta \varphi}{\varphi^*}$$

$$\varphi^* = \Delta \varphi \times \frac{v}{\Delta x} \quad \text{where} \quad 1 \text{ }^\circ/\text{s} = 2 \text{ CW/s}$$

When entering the values, note the following:

- Debouncing time of the "IN 3" or "IN 4" switching input (One-Shot trigger)
- Start time of the oscillating mirror (inertia)

- Select the mirror speed of the return phase, in accordance with the distances between the objects, so that the scan line returns to the starting position (Point A) at the right time.
- Check the theoretically calculated values on site and adapt them if required.

Fig. 10-42: One-Shot: Line scanner with oscillating mirror: calculating the number of scans for fence-type bar code positioning

10.8.3 Calculating the necessary capture area for the bar code if several bar codes are read on each object

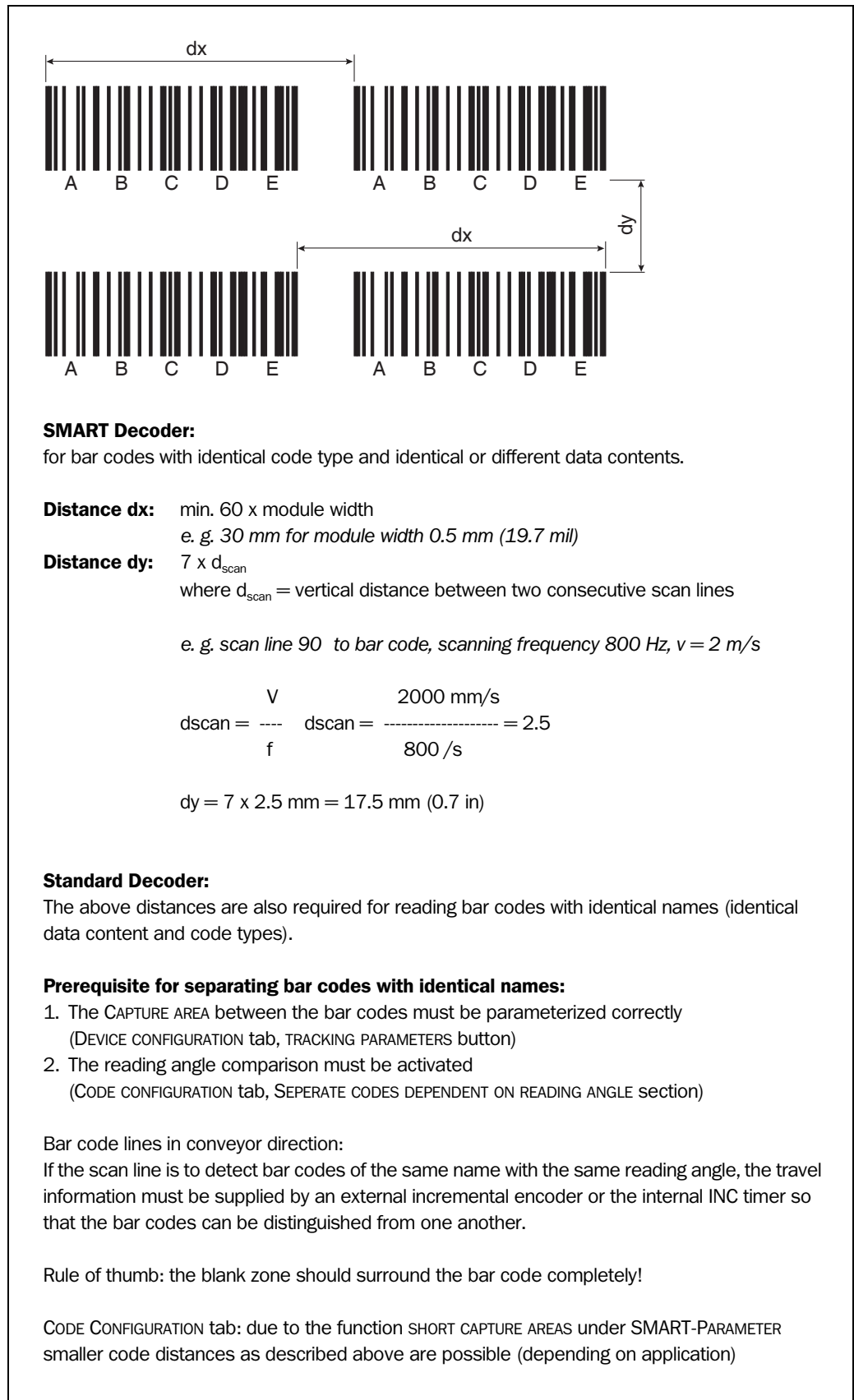

Fig. 10-43: Required distance between the bar codes on an object

10.9 Tables

10.9.1 Calculating the code length of a bar code

The code length of a bar code is the number of useful characters in the printed code including the check digit (if present). This code length must be specified in CLV-Setup.

If the code type of a bar code is known, the code length can be calculated by counting the bars and gaps. The relevant formulas are provided in [Table 10-8](#).

1. Count the bars and gaps as specified in [Table 10-8](#).
Do not forget to include the start and stop characters.
2. Calculate the code length using the formula in the table.
3. Enter the value in CLV-Setup as described in column 4 in the table.

Code type	Count	Calculation of code length ¹⁾²⁾	Entry in CLV-Setup
Code 39	Number of bars	$l_{\text{Code}} = \frac{\text{Number} - 10}{5}$	Calculated code length
2/5 Interleaved	Number of wide elements (bars and gaps)	$l_{\text{Code}} = \frac{\text{Number} - 1}{2}$	Calculated code length
EAN	Not applicable	13 characters (normal version) 8 characters (short version)	Activate 13-digit Activate 8-digit
UPC	Not applicable	12 characters (UPC A, normal version) 6 characters (UPC E, short version)	Activate Version A Activate version E
Codabar	Number of bars	$l_{\text{Code}} = \frac{\text{Number} - 8}{4}$	Calculated code length
Code 128 (character set A)	Number of bars	$l_{\text{Code}} = \frac{\text{Number} - 10}{3}$	Calculated code length
Code 93	Number of bars plus separator after the stop character	$l_{\text{Code}} = \frac{\text{Number} - 13}{3}$	Calculated code length
EAN 128	Number of bars	$l_{\text{Code}} = \frac{\text{Number} - 10}{3}$	Calculated code length
<p>1) Check digit optional for Code 39, 2/5 Interleaved, Codabar. Check digit always integrated in printed bar code with EAN, UPC, Code 128, Code 93, EAN 128 (suppressed automatically when the CLV490 read result is output)</p> <p>2) With only few exceptions each printed character that has to be decoded corresponds to an ASCII character. With Code 39 extended, Code 93, Code 128 and EAN 128, the number of characters in the data string of the CLV490 can be larger than the number of characters in the printed code because it comprises several character sets.</p>			

Table 10-8: Formulas for calculating the code length of a bar code

10.10 Discussion of a parameterization example

10.10.1 Application Conditions

- Reading with the CLV490's autofocus function
- Reading the packages from top
- Bar code with lines running vertically on the top side of the package, tilt across from the scan line: $\pm 30^\circ$
- Package height: 100 to 600 mm (3.9 to 23.6 in), package width: 200 to 550 mm (7.9 to 21.7 in), packages not guided
- Conveyer velocity: $v = 1$ m/s, conveyer belt width: 600 mm (23.6 in)
- Object distance between packages: min. 300 mm (11.8 in)
- Bar code: 2/5 Interleaved, module width 0.4 mm (15.7 mil), line length 15 mm (0.6 in), PR 2.5:1, Quality 3 or 4, 14 characters with test code (mod 10)
- Do not read under plastic sheeting, do not use very dark packages (spectral reflection $> 20\%$)
- 1 bar code per package
- Reading pulse is through a SICK photoelectric switch
- Output of read results via the host interface
- Parameterization of the CLV490 based on the factory defaults

Requirements:

- Testing the application for feasibility with the CLV490 before buying, with the help of the SMART calculation sheet (service provided by SICK)
- Choice of CLV490 type: here standard density line scanner (CLV490-0010)
- No objects irrelevant for reading protruding into conveyer path

Tools:

- Measuring tape (up to 3 m (9.84 ft))
- Protractor (to set up the CLV490)
- A PC with Windows and the SICK software "CLV-Setup"
- 3-core RS-232 data cable (null modem cable), pin 2 and pin 3 crossed, e. g. no. 2014054
- These operating instructions

10.10.2 Purpose of this discussion

- To make important clarifications
- To indicate the fitting location of the CLV490
- To point out the parameters to be set in the CLV-Setup user interface

10.10.3 Instructions for solution – step by step

- Determine the reading range and CLV490's installation height over the conveyer belt
- Determine the CLV490's distance measurement type
- Mount the CLV490
- Parameterize the CLV490
- Test an application

10.10.4 Important clarifications

- Sketch out the reading situation and enter the parameter values and variables for the CLV490.

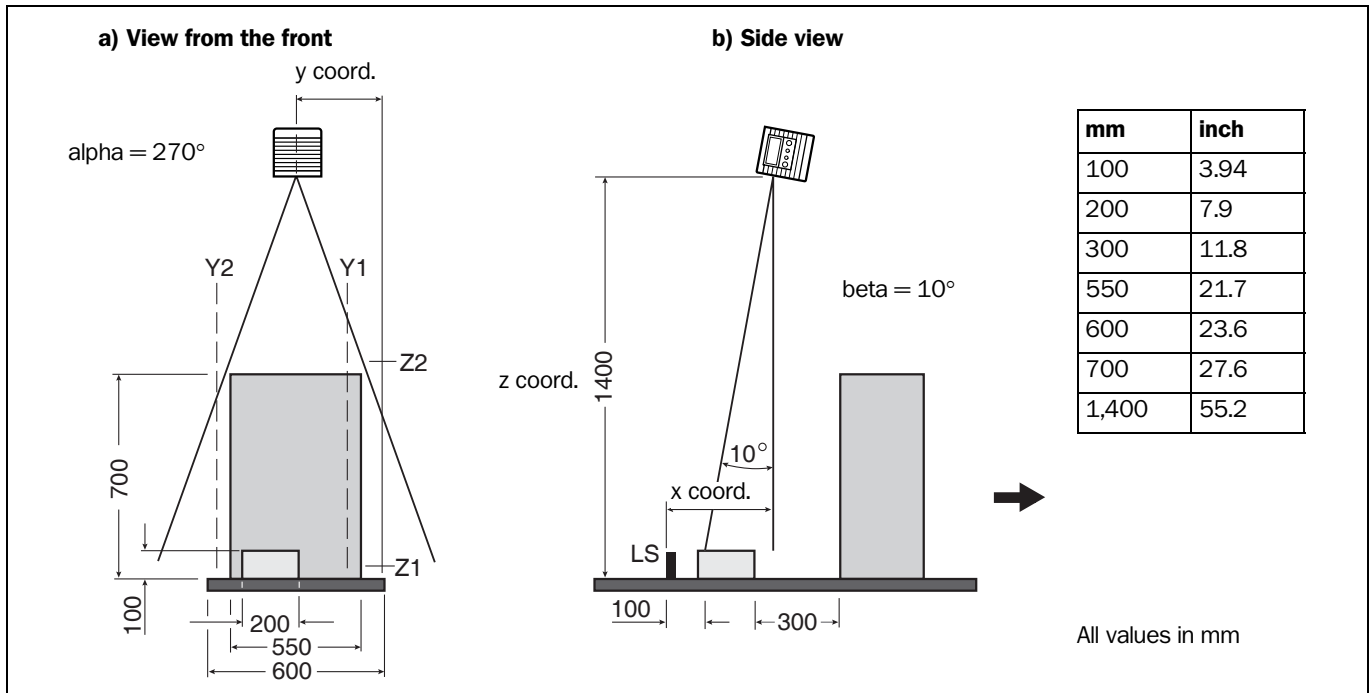

Fig. 10-44: Parameterization example: prepare a sketch of the reading situation

- Determine the reading range and installation height of the CLV490 above the conveyor belt:
 With a covered conveyor belt with a 600 mm (23.6 in) width, the CLV490 can read an object at a distance of 600 mm (23.6 in) (according to the reading field diagram in Fig. 10-1, Page 10-3). For a reserve of an additional 100 mm (3.9 in) and a maximum package height of 600 mm (23.6 in), the resulting reading range of the CLV490 can be set to 700 to 1,300 mm (27.6 to 51.2 in) from the reading window.
 The CLV490 is to be mounted 1,400 mm (55.2 in) above the conveyor belt, as the package must be at least 100 mm (3.9 in) high.
- For the required total field depth range of 600 mm (23.6 in), a height detection of the focal position changeover is required.

10.10.5 Mounting and electrical connection

1. Mount the CLV490 centered 1,400 mm (55.2 in) above the conveyor belt (vertically according to a) Fig. 10-44, reading window facing downward.
2. Align and screw in the CLV490 in a reading axis with the reading window at a 10° angle against the required reading direction as shown in b) Fig. 10-44
 The CLV490 can carry out a distance measurement from the front of the package to the top of the package while it is in motion.
3. Attach the pulse photoelectric switch and reflector to the conveyor belt so that there is a distance of approx. 100 mm (3.9 in) between the photoelectric switch and the scan line position on the package with the smallest height.
4. Connect the CLV490 to the CDB420 or CDM490 connection module.
 (see Chapter 5.2.3 Connections/cables for the CDB420 Connection Modules, Page 5-3) respectively Chapter 5.2.4 Connections/cables for the CDM490 Connection Module, Page 5-5.

5. Connect the pulse photoelectric switch to the CDB420 or CDM490 connection module (see [Chapter 5.5.7 Connecting the "Sensor" switching input, Page 5-22](#)).
6. Turn on the supply voltage to the CLV490.

10.10.6 Parameterize the CLV490 with the "CLV-Setup" program



1. Connect the PC to the CLV490's auxiliary interface (see [Chapter 5.5.6 Connecting the PC, Page 5-21](#))
2. Start Windows and the "CLV-Setup" program on the PC.
3. Invoke the CLV490's default setting in the "CLV-Setup" program (see [Chapter 6.1 Overview of steps for starting up the CLV490, Page 6-1](#)).
4. Parameterize the CLV490 with the help of [Chapter 6.4.4 Guide to parameterization menu, Page 6-9](#) and the tab cards by following the steps described.
5. After completing parameter value alterations, download them to the CLV490! (see [chapter Chapter 6.4.1 Configuring the CLV490 via the user interface of CLV-Setup, Page 6-5](#)).

1. Setting up the autofocus function (Part 1): READING CONFIGURATION tab

- Set the following parameters:
 - Scanning frequency: **800 Hz**
 - Start/stop ratio: **auto**
 - Focus control: **autofocus**
 - Autofocus mode: **differential background**

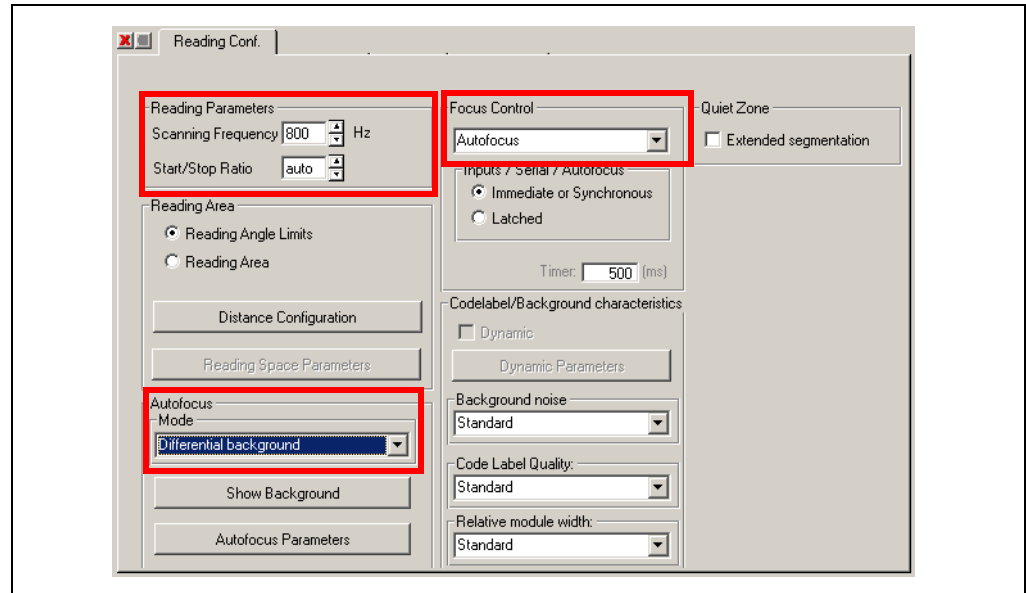

Fig. 10-45: Parameterization example: settings on the "Reading Configuration" tab

- Click on the AUTOFOCUS PARAMETERS button. The AUTOFOCUS PARAMETERS tab then opens ([Fig. 10-46](#)).
- Set the following parameters:
 - Preference of focus distance: **Fix focus position: 1,200 mm** (47.3 in) (approx. 100 mm (3.9 in) above the packet with the smallest height)

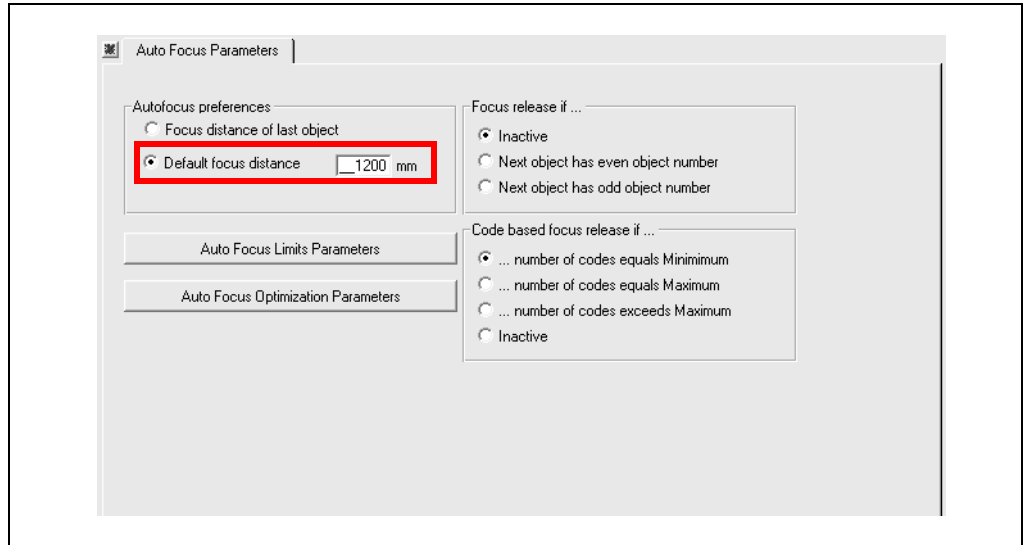

Fig. 10-46: Parameterization example: "Autofocus Parameters" tab

- To set the **background**, click the AUTOFOCUS LIMITS PARAMETERS button. The AUTOFOCUS LIMITS tab then opens (Fig. 10-47). The background is formed using the autofocus area's terminating planes. The CLV490 registers the altered reading distances in this area only.
 - Autofocus limitation: min: **600 mm (23.6 in)**; max: **1,400 mm (55.2 in)**
 - Autofocus space: Right edge of conveyor (Y1): **50 mm (2 in)**
 (Limiting levels Left edge of conveyor (Y2): **550 mm (21.7 in)**
 from feed level) Level of conveyor (Z1): **50 mm (2 in)**
 Maximum scanning height (Z2): **800 mm (31.5 in)**

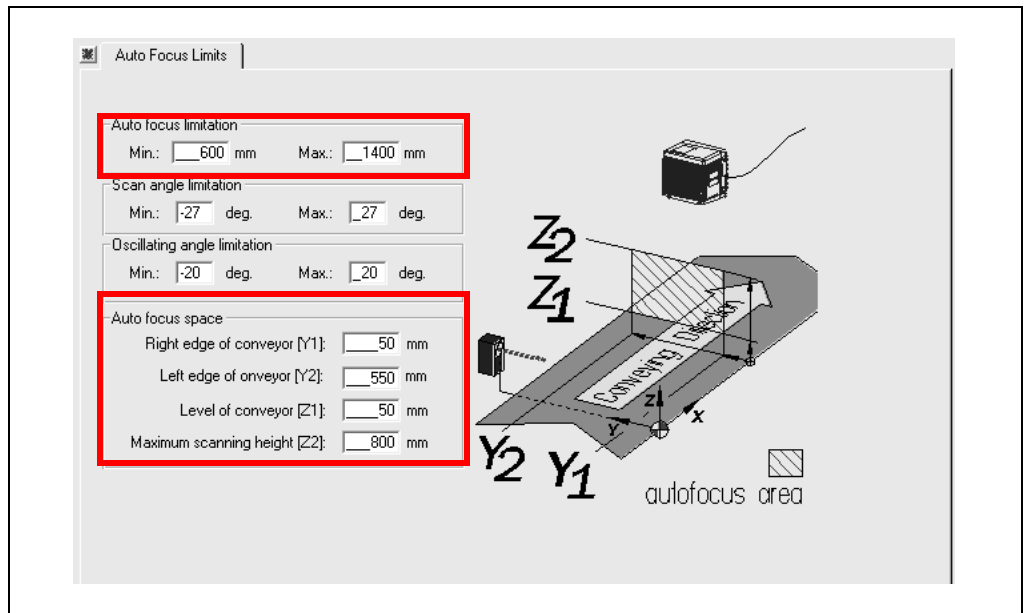

Fig. 10-47: Parameterization example: "Autofocus Limits" tab

- Close the AUTOFOCUS LIMITS PARAMETERS tab.

- On the AUTOFOCUS PARAMETERS tab, click the AUTOFOCUS OPTIMIZATION PARAMETERS button. The AUTOFOCUS OPTIMIZATION PARAMETERS tab then opens (Fig. 10-48).
- Set the following parameters:
 - Delay of focus change
Timeout: **50 ms**
Hysteresis: **50 mm (2 in)**
 - Distance Measurement: **active**
Source of distance information: **internal**
Smooth filter active: **active** Length: **3** (default setting)

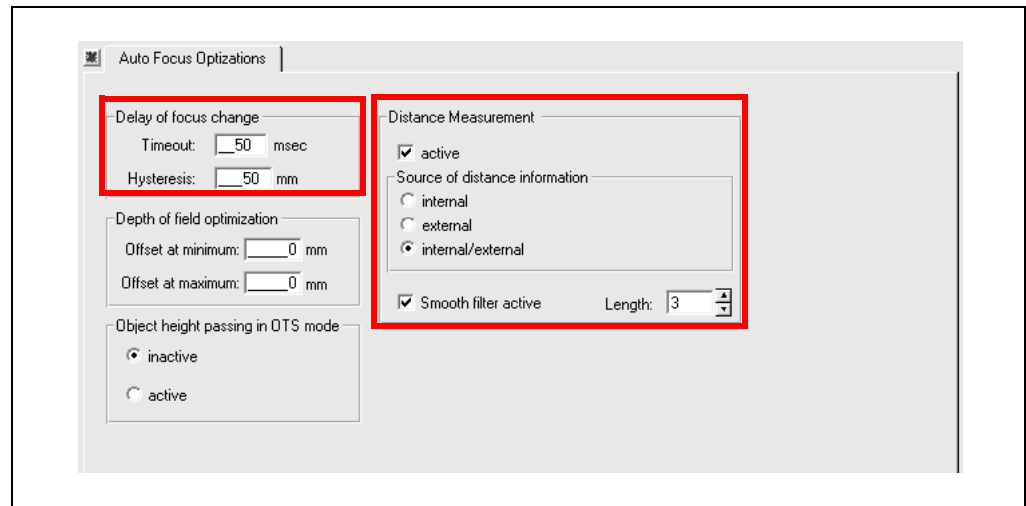

Fig. 10-48: Parameterization example: "Autofocus Optimizations" tab

- Close the AUTOFOCUS OPTIMIZATION PARAMETERS tab.

2. Setting up the autofocus function (Part 2): DEVICE CONFIGURATION tab

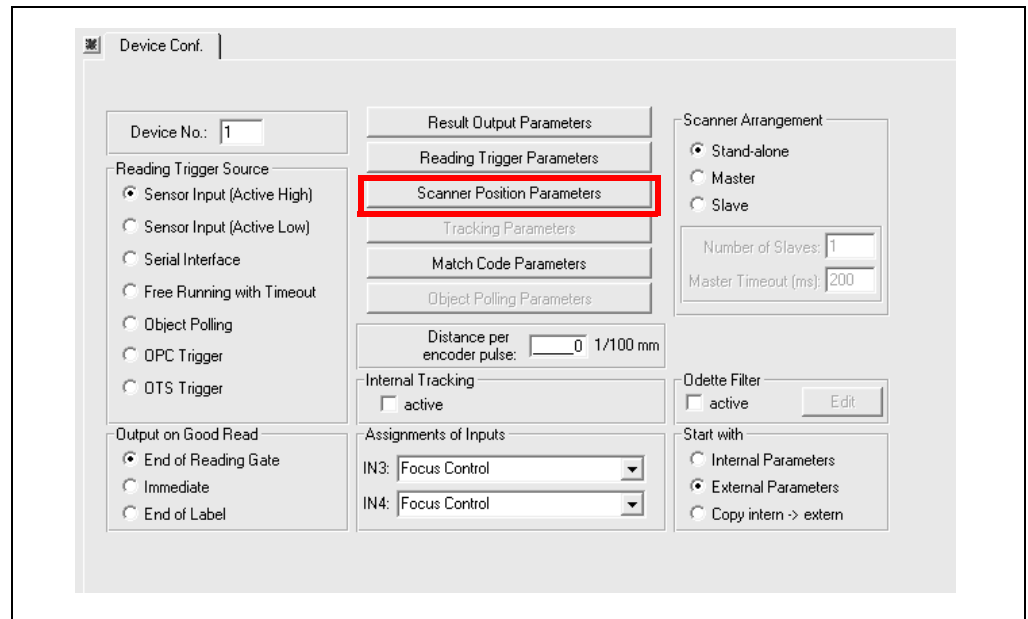

Fig. 10-49: Parameterization example: Buttons on the "Device Configuration" tab

- Click on the SCANNER POSITION PARAMETERS button.
The SCANNER POSITION PARAMETERS tab then opens (Fig. 10-50).

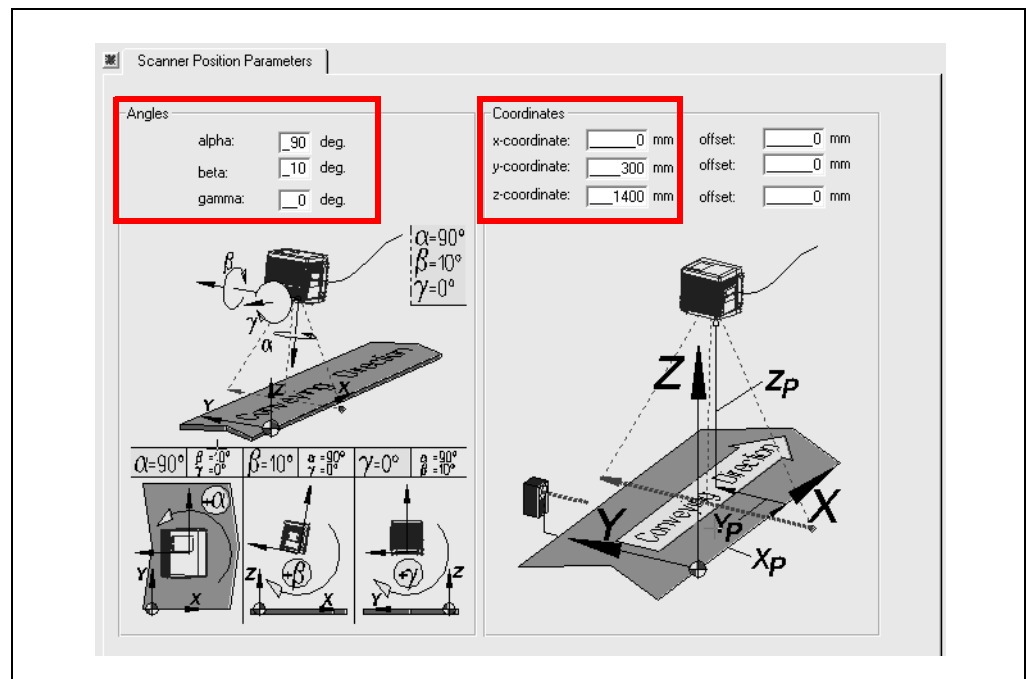

Fig. 10-50: Parameterization example: "Scanner Position Parameters" tab

Set the following CLV490 position definition parameters regarding the movement level (see also Fig. 10-44, Page 10-61):

- Set the following parameters in the ANGLES section:
 - Angle alpha: **90 degrees** (Laser beam's direction of deflection relative to the direction of conveyor belt.
 - Angle beta: **10 degrees** (Laser beam's angle of incidence relative to the perpendicular in the area (Skew to the barcode), 10 degrees in the direction of feed)

- Angle gamma: **0 degrees** (Divergence of the scanner (reading windows) from the perpendicular in the plane askew to the direction of feed)
- Set the following parameters in the COORDINATES section:
 - X coordinate: Measure **the distance from the pulse photoelectric switch to the CLV490's reading window perpendicular!**
(x offset + x coordinate = the distance from the pulse photoelectric switch to the CLV490's reading window perpendicular)
 - Y coordinate: **300 mm (11.8 in)** (The middle of the CLV490 to the left edge of the conveyor belt in the direction of conveyor belt)
 - Z coordinate: **1,400 mm (55.2 in)** (Height of the CLV490 above the conveyor belt)
- Close the SCANNER POSITION PARAMETERS tab.

3. Set the reading pulse source: DEVICE CONFIGURATION tab

- In the READING TRIGGER MODE section click the option **Sensor Input (Active High)**.
- In the Output on Good read section click the option **End of label**.

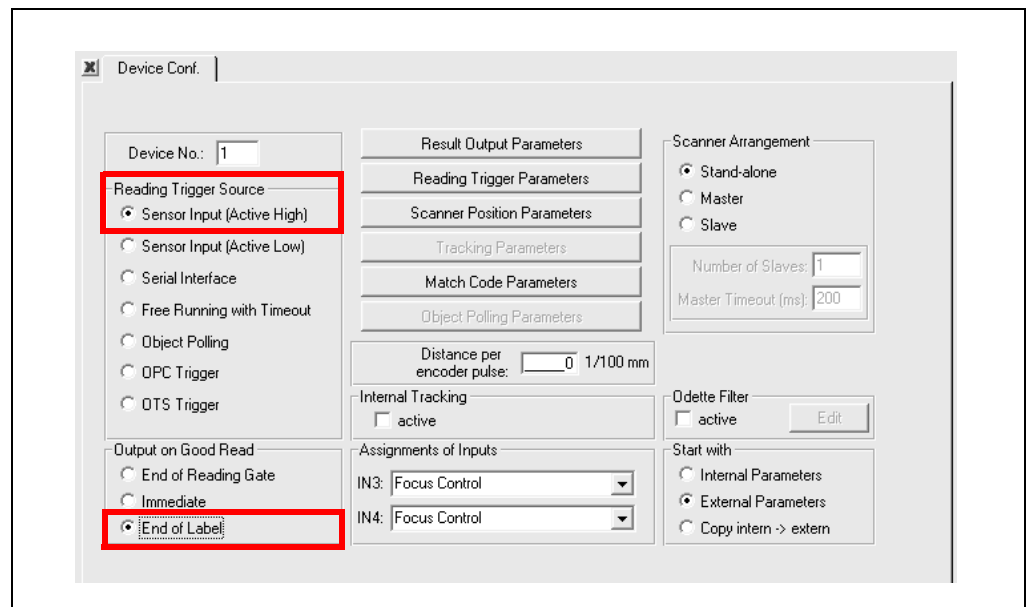

Fig. 10-51: Parameterization example: Settings on the "Device Configuration" tab

- Close the tab.

4. Set the evaluation properties: CODE CONFIGURATION tab

- Set the following parameters:
 - Codes: **2/5 Interleaved; deactivate all other code types!** (remove check)
 - Number of Codes: **Minimum 1, Maximum 1**
 - Seperate codes dependent on reading angle: **deactivate** (remove check)
 - Decoder: **SMART/Standard**

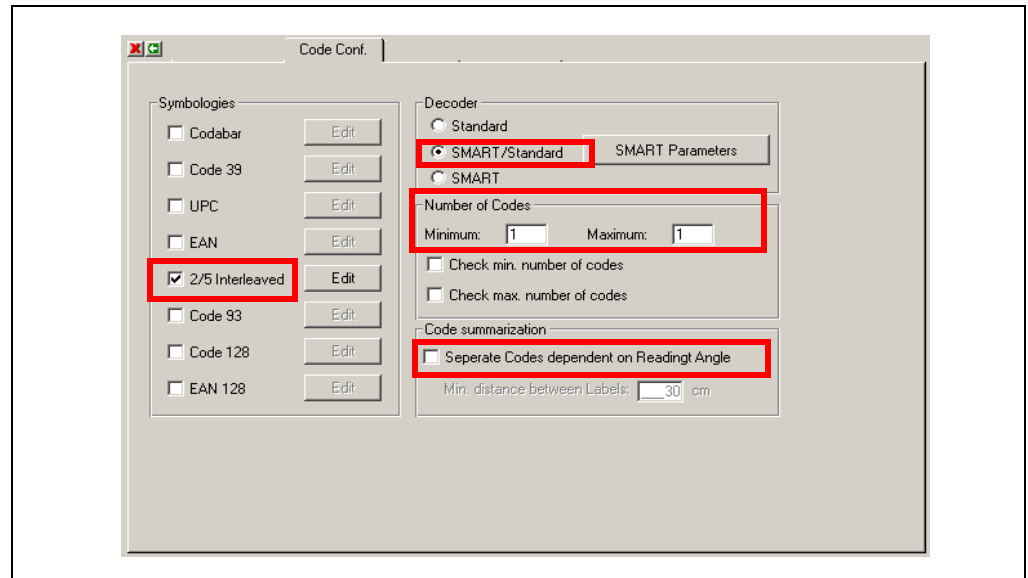

Fig. 10-52: Parameterization example: settings on the "Code Configuration" tab

- For 2/5 interleaved, click on the EDIT button. The 2/5 INTERLEAVED tab then opens (Fig. 10-53).
- Set the following parameters:
 - Code Length: **Fixed; length 1: 14 characters**
 - Multiple Reads for Length 1: **3**
 - Check Digit Test for Length 1: **mod 10**
 - Transmit Check Digit: **activate**
 - Transmit Leading Zero: **activate**

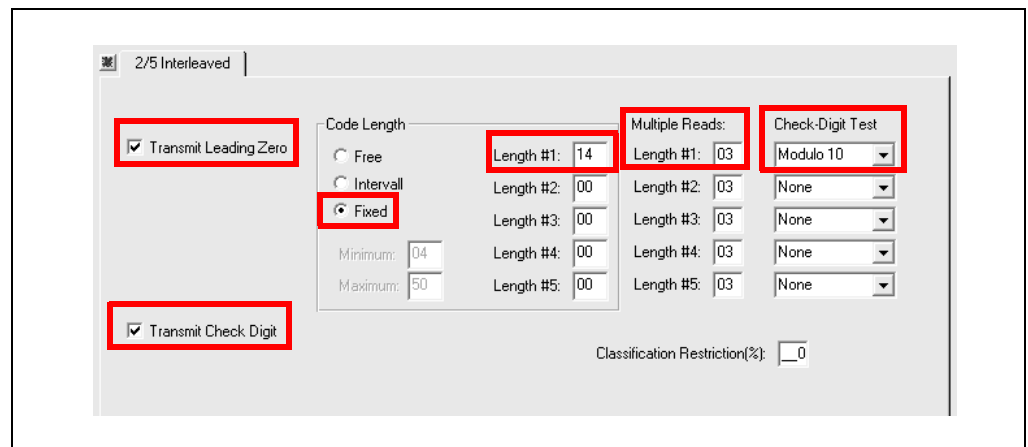

Fig. 10-53: Parameterization example: "2/5 Interleaved" tab

- Close the tab.

5. Set the output properties: HOST INTERFACE tab

- Set the CLV490's end-user communication condition parameters.

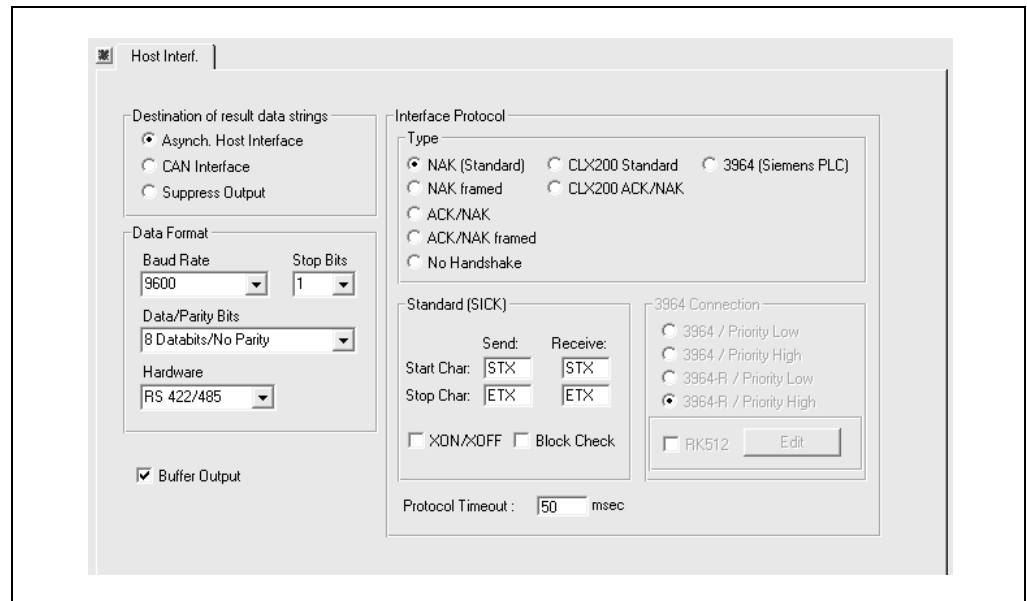

Fig. 10-54: Parameterization example: "Host interface" tab (default setting)

DATA STRINGS tab

- Set the CLV490 output message format in the end-user communication conditions.

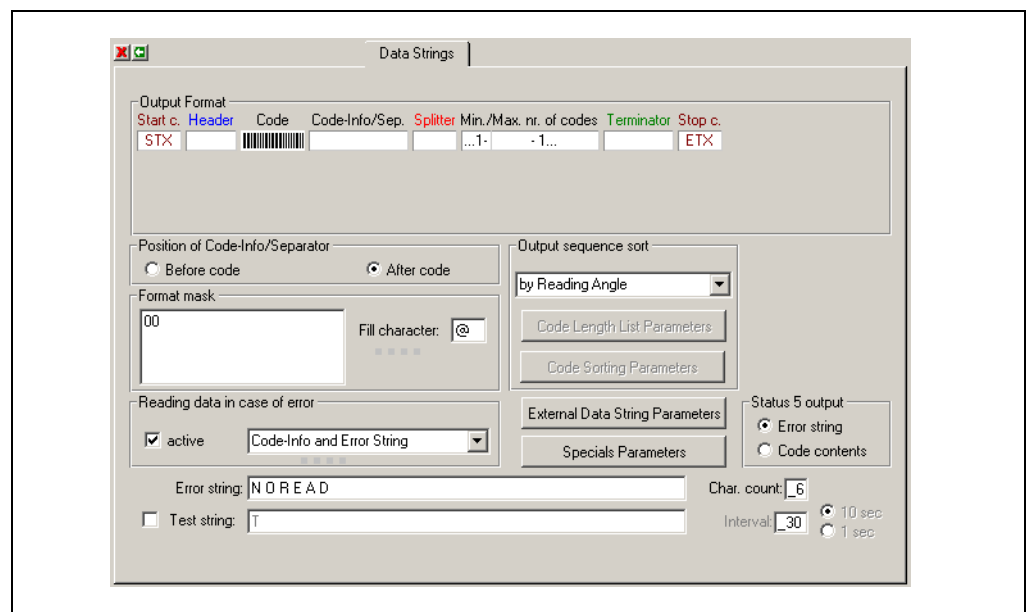

Fig. 10-55: Parameterization example: "Data Strings" tab (default setting)

- Perform a download to CLV490.

10.10.7 Testing the application

- Check the reading rate with the Terminal Emulator in the CLV-Setup while an application is running.
The reading rate should be > 90%.

10.11 Special applications and procedures

10.11.1 Auxiliary input via auxiliary interface

If the CLV490 cannot read a bar code in Reading mode (e. g. if there is no bar code on the object), the data content of the bar code can be sent subsequently to the host by using the "Auxiliary input" function. In this way, the sequence of reading results can be completed if necessary.

The auxiliary input function uses the auxiliary interface of the CLV490 exclusively and features two options:

- Manual entry of the data content on the keyboard of a connected terminal or PC (Terminal Emulation function)
- Entry of the bar code using a hand-held reader. The data is then forwarded to the CLV490 via an internal or external decoder.

Fig. 10-56 shows the basic auxiliary input principle.

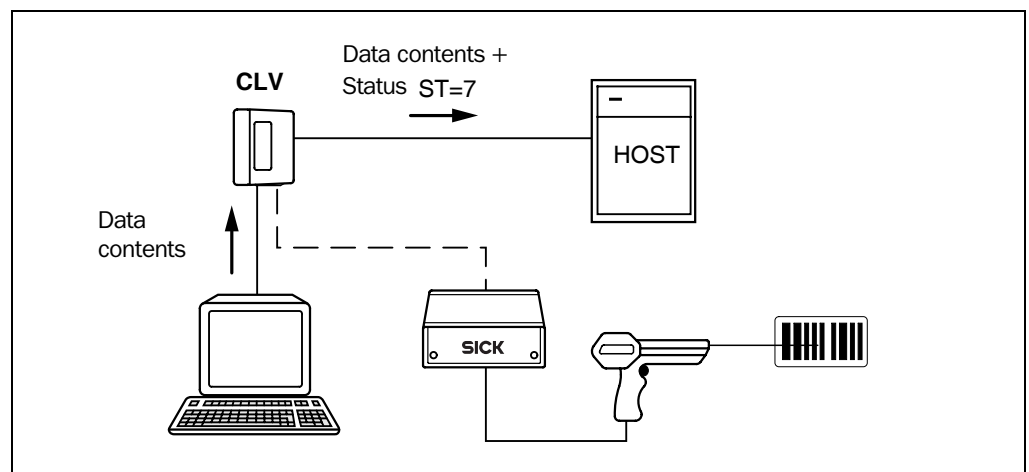

Fig. 10-56: Auxiliary input via the auxiliary interface of the CLV490

The CLV490 sends the data content of the bar code that it receives via the auxiliary interface to the host in the same format as the other reading results on the host interface. Each string can contain the data from a bar code with a maximum length of 50 characters. The CLV490 automatically enters the status $ST = 7$ if the error status has been enabled for transmission. The values of the other reading diagnosis data in the data string do not have any significance.

To enable the CLV490 to receive the data content of the bar code on the auxiliary interface, you must switch the operating mode on the interface to auxiliary input.



1. Connect the PC to the **auxiliary interface** on the CLV490 using a 3-core RS 232 data cable (null modem cable) (CDB420 or CDM490: connect the PC to the internal 9-pin "Aux" plug). See [Chapter 5.5.6 Connecting the PC, Page 5-21](#).
2. Start CLV-Setup on your PC.
See [Chapter 10.6.3 Starting CLV-Setup, Page 10-46](#).
3. Choose the AUXILIARY INTERFACE tab.
4. Choose the AUXILIARY INPUT option from the drop-down list.
5. Download the changes to the CLV490.
To do so, click the AUXILIARY INPUT option again with the right mouse button and choose DOWNLOAD PARAMETER in the context menu.
CLV-Setup copies the parameter to the CLV temporarily.

The auxiliary interface then operates temporarily in "Auxiliary input" mode (until the CLV is switched off).

Entering the bar code using the Terminal Emulator function in CLV-Setup

1. Click  on the toolbar.
The Terminal Emulator is launched.
The CLV490 is in Reading mode.
2. Click the EXTENDED radio button in the TERMINAL MODE section.
The start and stop characters used by the Terminal Emulator are displayed at the top of the screen, on the left and right of the text input field.
Fig. 10-57 shows the Terminal Emulator window in extended mode.
3. Use the drop-down lists to set the start and stop characters to NUL.
4. Enter the data content of the bar code (character string) on the keyboard.
Use the backspace key to correct any input errors.
The data content must not contain control characters.
5. Press the [RETURN] or [ENTER] key.
The CLV490 then interprets all further characters as a new data string.
CLV-Setup sends the character string to the CLV490 and deletes the entry in the text field. The CLV490 does not send an echo.
6. Once the active reading pulse has ended, the CLV490 sends the data received from the PC to the host via the host interface.

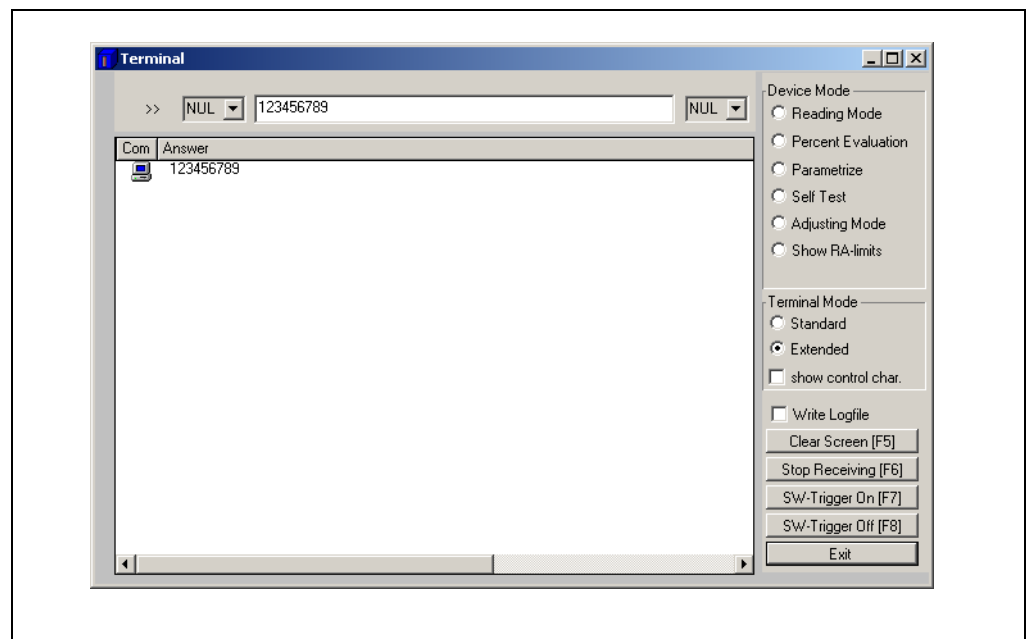

Fig. 10-57: CLV-Setup: auxiliary input via the Terminal Emulator

Entering a bar code using a terminal/PC keyboard

1. Connect the terminal /PC with Terminal Emulation program to the auxiliary interface on the CLV490 (via CDB420 or CDM490). For the pin assignment, see [Chapter 5.5.6 Connecting the PC, Page 5-21](#).
2. Set the communication parameters and data output format as shown in [Table 10-9](#).

Parameter	Value
Data transmission rate	9,600 bd
Data bits	8
Parity	None
Stop bits	1
Data output format	Data terminator e. g. 1234 CR

Table 10-9: Communication parameters on the terminal/PC for the auxiliary input

3. Enter the data content of the bar code on the keyboard.
The terminal sends the individual characters to the CLV490 immediately.
Use the backspace key to correct input errors.
4. Terminate the data content with the control character <CR>.
The CLV490 then interprets all further characters as a new data string and ignores other control characters. The data content itself must not contain any control characters.
5. Once the active reading pulse has ended, the CLV490 sends the data received from the PC to the host via the host interface.

Entering bar codes using a hand-held scanner (with integrated decoder)

1. Connect the hand-held scanner with decoder to the auxiliary interface of the CLV490 (via CDB420 or CDM490). For the pin assignment, see [Chapter 5.5.6 Connecting the PC, Page 5-21](#).
2. Set the data format and communication parameters on the hand-held scanner as shown in [Table 10-9](#).
3. Read the bar code with the hand-held scanner.
Once the active reading pulse has ended, the CLV490 sends the data received from the PC to the host via the host interface.

If you connect a SICK Hand-held Scanner from the IT 38xx/46xx/48xx/58xx series, set the communication parameters and data output (data + terminator) as shown in [Table 10-10](#).

Parameter	Value
Data transmission rate	9,600 bd
Data bits	8
Parity	No
Stop bits	1
Data interface	RS 232
Prefix (Header)	Clear all Prefixes
Suffix (Terminator)	CR

Table 10-10: Communication parameter settings for the SICK Hand-held Scanner from the IT 38xx/46xx/48xx/58xx series

10.11.2 Connection to Profibus DP

See Operating Instructions "*CMF400-1x01 Field Bus Gateway for Profibus DP*" (no. 8010462, English edition).

10.11.3 Connection to the DeviceNet

See Operating Instructions "*CMF400-2101 Field Bus Gateway for DeviceNet*" (no. 8010464, English edition).

10.11.4 Connection to Ethernet TCP/IP

See Operating Instructions "*CMF400-3101 Field Bus Gateway for Ethernet TCP/IP*" (no. 8010735, English edition).

10.11.5 Building a CAN Scanner Network

See Operating Instructions "*Application of the CAN interface*" (no. 8009180, English edition).

10.11.6 Integration in an OPS reading system

See Operating Instructions "*Omni Tracking System OTS400*" (no. 8008869, English edition).

10.12 Replacing a CLV490 (copying the parameter set)

There are two methods of replacing a CLV490 and transferring the current parameter set to the new device:

- By downloading the parameters from CLV-Setup
- By importing the parameter set from the external memory

The parameter set can only be transferred between identical device types (e. g. from one CLV490 to another CLV490, etc.).

10.12.1 Downloading the parameter set



To download the parameter set, you must connect a PC running the "CLV-Setup" software to the replacement device. The parameter set of the CLV490 that is to be replaced must be available as a configuration file in CLV-Setup, otherwise the device must be parameterized from scratch.

1. Disconnect the power supply to the CDB420 or CDM490 Connection Module (of the CLV490).
2. Disconnect all cable connectors from the CLV490.
3. Remove the CLV490 from the bracket.
Before doing so, mark the position and alignment on the bracket/station.
4. Mount, align, and connect the replacement device.
5. Connect the PC to the auxiliary interface on the CLV490 using a 3-core RS 232 data cable (null modem cable) (CDB420 or CDM490: connect the PC to the internal, 9-pin "Aux" plug). See [Chapter 5.5.6 Connecting the PC, Page 5-21](#).
6. Switch on the power supply to the CDB420 or CDM490.
Once the CLV490 has started, the "Device Ready" LED lights up.
7. Switch on your PC and start Windows.
8. Start CLV-Setup.
If the communication parameters on the PC and CLV490 are identical, CLV-Setup uploads the parameter set from the CLV490 and displays the values on the tabs.
9. Open the archived parameter set as a configuration file "*.scl" in CLV-Setup and download it to the CLV490.
10. Confirm the dialog box by choosing the TEMPORARY storage option.
11. Check whether the CLV490 reads the bar codes correctly.
Correct the parameter settings if necessary.
12. Finally, download the tested parameter set to the CLV490 and save it with the PERMANENT storage option.
The parameter set is transferred permanently to the replacement device.
13. Save the modified parameter set as a new configuration file in CLV-Setup.

Troubleshooting

If the software version on the replacement device is older than the version on the old device (e. g. new device is from warehouse stock), the parameter set transferred may contain coded parameters or parameter values that cannot be interpreted by the older software. The new device, however, outputs an error message in CLV-Setup for each of these parameters/values when the parameter set is downloaded.

- Check whether all of the parameter settings used are necessary to configure the CLV490 for the current reading application. If necessary, replace the software version in the new device.

If the software version on the new device is more recent than that on the old one, the default settings in the imported parameter set will include parameters that were not contained in the old version.

- Upload the parameter set and check whether the new parameters are relevant for configuring the CLV490 for the current reading application. If necessary, change the parameter values and download the parameter set to the CLV490 again. Save the new parameter set as a configuration file in CLV-Setup.

See also [Chapter 10.6.10 Unknown parameters, Page 10-51](#).

10.12.2 Importing the parameter set from the external memory

a) External memory in the connector cover

A PC does not have to be connected to import the parameter set from the external memory. The parameter set in the external memory must contain an up-to-date copy of the set used by the CLV490 that is to be replaced. Otherwise, the replacement device will import a different parameter set to its RAM when it is started. The start option in the device must be set to START WITH EXTERNAL PARAMETERS. This is the default setting.

1. Switch off the power supply to the CDB420 or CDM490 Connection Module (of the CLV490).
2. Remove the connector cover (containing the parameter memory) from the CLV490.
3. Remove the CLV490 from the bracket.
Mark the position and alignment of the CLV490 on the bracket station.
4. Mount the connector cover on the terminals correctly and screw it into place.
5. Mount and align the replacement device.
6. Switch on the power supply to the CDB420 or CDM490.
The CLV490 starts and loads the parameter set from the external memory to the RAM.
The "Device Ready" LED blinks for approx. 10 s and then lights up constantly.

The parameter set is transferred temporarily to the replacement device. It is lost when the device is switched off but is loaded again from the external memory the next time the CLV490 starts.

See also [Chapter 10.3.8 Replacing a CLV490, Page 10-39](#).

Troubleshooting

If the software version on the replacement device is older than that of the parameter set in the external memory (e. g. if the replacement device originated from the warehouse), the loaded parameter set may contain parameters or parameter values that cannot be interpreted by the older software. In this case, the "Device Ready" and "Read Result" LEDs blink together for approx. 10 s, after which the "Device Ready" LED lights up constantly. See also [Chapter 10.6.10 Unknown parameters, Page 10-51](#).

If the software on the replacement device is newer than that of the parameter set in the external memory, the parameter set loaded from the external parameter memory to the replacement device will contain new parameters that are set to the default values.

b) External memory CMC400 in the CDB420 or CDM490 Connection Module

For procedure see [Chapter 10.3.1 Function of the external parameter memory, Page 10-35](#).

10.13 Ordering Information

10.13.1 CLV490 Bar Code Scanner

Part. no.	Type (red light)	Scanning method	Resolution	Reading window	Heater
1019311	CLV490-2010	Line scanner	High-Density	End	No
1019313	CLV490-3010	Line scanner with oscillating mirror	High-Density	Side	No
1019312	CLV490-2011	Line scanner	High-Density	End	Yes
1019314	CLV490-3011	Line scanner with oscillating mirror	High-Density	Side	Yes
1016958	CLV490-0010	Line scanner	Standard	End	No
1016959	CLV490-1010	Line scanner with oscillating mirror	Standard	Side	Yo
1016960	CLV490-0011	Line scanner	Standard	End	Yes
1016961	CLV490-1011	Line scanner with oscillating mirror	Standard	Side	Yes
1018872	CLV490-6010	Line scanner	Low-Density	End	No
1019094	CLV490-7010	Line scanner with oscillating mirror	Low-Density	Side	No
1019095	CLV490-6011	Line scanner	Low-Density	End	Yes
1019096	CLV490-7011	Line scanner with oscillating mirror	Low-Density	Side	Yes

Table 10-11: CLV490 variants

10.13.2 Accessories: Mounting devices

Order No.	Description	Figure
2013824	Angle bracket, single, with 2 screws M6 x 10 mm (0.39 in), self-locking	Fig. 10-58, Page 10-83
2018435	Articulated bracket (two angle brackets 2 013 824), with 2 screws M6 x 10 mm (0.39 in), self-locking	Fig. 10-59, Page 10-83
2016110	Quick clamping device, complete with securing material	Fig. 10-60, Page 10-83
2022996	Hinge bracket, with 2 screws M6 x 12 mm (0.47 in), self-locking	Fig. 10-62, Page 10-84

Table 10-12: Accessories: mounting accessories

10.13.3 Accessories: Hoods

Order No.	Description	Design
2032070	Mirror hood (for reduction of the required mounting area). Using a CLV490 Bar Code Scanner with heater in the hood is not recommend. Dimensioned drawing see Fig. 10-62, Page 10-84	

Table 10-13: Accessories: Hood

10.13.4 Accessories: Connection modules







Order No.	Type	Description	Design
1023885	CDB420-001	Connection Module for one CLV490, with: <ul style="list-style-type: none"> • 1 x 15-pin D Sub HD socket • 4 x plastic cable glands M16 (dia. 4.5 to 10 mm (0.18 to 0.39 in)) • terminal strips (signal distributor) for connecting the data and function interfaces (digital switching input and outputs) • 1 x internal 9-pin D Sub plug "Aux" • 5 x LED (status indicator) • operating voltage 10 to 30 V DC • polycarbonate housing, enclosure rating max. IP 65¹⁾ • operating temperature -35²⁾ to +40 °C (-31 to +104 °F) • dimensions 124.2 mm x 113.1 mm x 53.9 mm (4.89 in x 4.46 in x 2.12 in) • weight approx. 260 g (9.17 oz) 	
1024305	CDB420-101	as CDB420-001, but with: <ul style="list-style-type: none"> • 2 x plastic cable glands M16 (dia. 4.5 to 10 mm (0.18 to 0.39 in)) • 2 x 5-pin M12-connections (1 x plug, 1 x socket) 	
1027094	CDB420-201	as CDB420-001, but with: <ul style="list-style-type: none"> • 2 x plastic cable glands M16 (dia. 4.5 to 10 mm (0.18 to 0.39 in)) • 2 x plastic cable glands M12 (dia. 4.5 to 7 mm (0.18 to 0.28 in)) 	—
1025363	CDM490-0001	Connection Module for one CLV490, with: <ul style="list-style-type: none"> • 1 x 15-pin D Sub HD socket and 15-pin D Sub HD plug • 6 x plastic cable glands M16 (dia. 4.5 to 10 mm (0.18 to 0.39 in)) • terminal strips (signal distributor) for connecting the data and function interfaces (digital switching input and outputs) • 1 x internal 9-pin D Sub plug "Aux" • 11 x LED (status indicator) • operating voltage 10 to 30 V DC, power consumption 0.5 W without CLV490 • polycarbonate housing, enclosure rating max. IP 65¹⁾ • operating temperature -35²⁾ to +40 °C (-31 to +104 °F) • dimensions 191.9 mm x 166.2 mm x 69.7 mm (7.56 in x 6.55 in x 2.75 in) • weight approx. 870 g (30.7 oz) 	
1) If SICK standard connection cables are used 2) Without any mounting or electrical installation work, otherwise -20 °C (-4 °F)			

Table 10-14: Accessories: connection modules

10.13.5 Accessories: Extensions for connection modules

Order No.	Type	Description	Design
1023850	CMC400-101	<p>Parameter memory (Connection Module Cloning)</p> <ul style="list-style-type: none"> plug-in module for the CDB420 or CDM490 Connection Module storage of parameter set for CLV490 (from firmware V 3.50) rotary code switch for activating the net work mode for the CLV490 operating voltage 10 to 30 V DC via CDB420 or CDM490, power consumption 0.5 W operating temperature 0 to +40 °C (+32 to +104 °F) 	
2029466	CDM400 ¹⁾	<p>Display module (Connection Display Module)</p> <ul style="list-style-type: none"> in optional cover for the CDM490 Connection Module representation of reading results, reading diagnosis data and messages from the CLV490 (from firmware version V 3.50) 4 x 20 digits (LCD) with keyboard connection to the CDM490 via ribbon cable operating voltage 18 to 30 V DC via CDM490, power consumption 1 W operating temperature 0 to +40 °C (+32 to +104 °F) <p>Prerequisite: CMC400-101 parameter memory for controlling the display.</p>	
2030091	CMP490 ²⁾	<p>Power Supply Module (Connection Module Power)</p> <ul style="list-style-type: none"> in optional cover for the CDM490 Connection Module Power supply for CLV490 from an AC power line Input 100 to 250 V AC/50 to 60 Hz output 24 V DC, max. 25 W (short-circuit proof) connection to the CDM490 via ribbon cable operating temperature 0 to +40 °C (+32 to +104 °F) 	
1026241	CMF400-1001	<p>Field bus gateway (Connection Module Fieldbus)</p> <ul style="list-style-type: none"> plug-in module for the CDM490 Connection Module for connecting one CLV490 (from firmware version V 3.50) to Profibus-DP (slave) via RS 232 data interface front panel: 9-pin D Sub socket for bus connection, enclosure rating IP 20 on the gateway 5-core terminal strip for connecting 2 digital inputs and 2 digital output connection to the CDM490 via connector operating voltage 18 to 30 V DC via CDM490, power consumption 2 W operating temperature 0 to +40 °C (+32 to +104 °F) 	 
1026643	CMF400-1101	<p>as CMF400-1001, but:</p> <ul style="list-style-type: none"> front panel: 9-pin D Sub socket for bus connection, enclosure rating IP 65 	

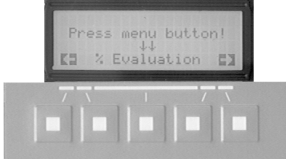
1) simultaneous operation together with the CMP490 Power Supply Module not possible
 2) simultaneous operation together with the CMD400 Display Module not possible

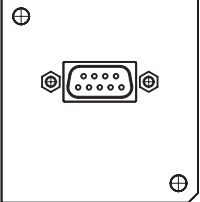
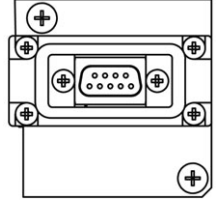
Table 10-15: Accessories: Extensions for connection modules

Order No.	Type	Description	Design
1028663	CMF400-1201	as CMF400-1001, but: <ul style="list-style-type: none"> front panel: 2 x 5-pin M12 connection (1 x plug, 1 x socket) for bus connection, enclosure rating IP 65 	
1026242	CMF400-2101	Field bus gateway (Connection Module Fieldbus) <ul style="list-style-type: none"> plug-in module for the CDM490 Connection Module for connecting one CLV490 (from firmware version V 3.50) to DeviceNet (slave) via RS 232 data interface front panel: shielded 5-pin M12 plug for bus connection, enclosure rating IP 65 on the gateway 5-core terminal strip for connecting 2 digital inputs and 2 digital output. Connection to the CDM490 via connector operating voltage 18 to 30 V DC via CDM490, power consumption 2 W operating temperature 0 to +40 °C (+32 to +104 °F) 	
1026357	CMF400-3101	Field bus gateway (Connection Module Fieldbus) <ul style="list-style-type: none"> plug-in module for the CDM490 Connection Module for connecting one CLV490 (from firmware version V 3.50) to Ethernet TCP/IP via RS 232 data interface front panel: shielded 8-pin RJ-45 socket for bus connection, enclosure rating IP 65 on the gateway 5-core terminal strip for connecting 2 digital inputs and 2 digital outputs connection to the CDM490 via connector operating voltage 18 to 30 V DC via CDM490, power consumption 3 W. operating temperature 0 to +40 °C (+32 to +104 °F) 	
6029030	–	Profibus connector, IP 65, for CMF400-1101	–
6029064	–	Ethernet patch cable, IP 65, 1 m (39.4 in), für CMF400-3101	–

Table 10-15: Accessories: Extensions for connection modules (contd.) (contd.)

10.13.6 Accessories: Cables, external parameter memories in connector cover, connector covers

a) CLV490 without heater

Temperature range of connection material:

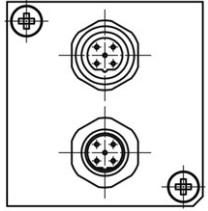
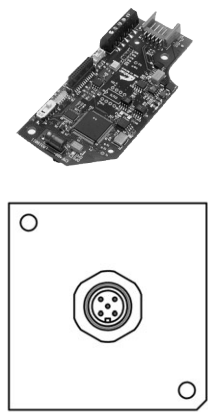
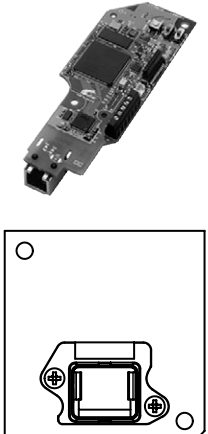
Stationary: -30 to +70 °C (-22 to +158 °F); moving: 0 ... +70 °C (+32 to +158 °F)

Order No.	Description	Wires	Length	Connection
2020302	 <p>Connection cable for data interfaces ("Host/Term") or function interfaces ("I/O"), dia. 8 mm (0.32 in), shielded, with 15-pin D Sub HD socket and 15-pin D Sub HD plug. Pin assignment identical to device connection, all pins connected. Enclosure rating max. IP 20. Required: 2 per CLV490</p>	15 x 0.25 mm ² (24 AWG)	3 m (3.84 ft)	CLV490 to CDM490
2021815	as 2020302, but longer	15 x 0.25 mm ² (24 AWG)	10 m (32.8 ft)	as above
2020303	 <p>Connection cable for data interfaces ("Host/Term"), dia. 8 mm (0.32 in), shielded, with 15-pin D Sub HD socket and open end (crimped wires), all pins connected. Enclosure rating max. IP 20. Required: 1 per CLV490</p>	15 x 0.25 mm ² (24 AWG)	3 m (3.84 ft)	CLV490 to host (free wiring)
2020264	 <p>Connection cable for function interfaces and power supply ("I/O"), dia. 8 mm (0.32 in), shielded, with 15-pin D Sub HD plug and open end (crimped wires). All pins connected. Enclosure rating max. IP 20. Required: 1 per CLV490</p>	15 x 0.25 mm ² (24 AWG)	3 m (3.84 ft)	CLV490 to sensors, PLC and non-SICK power pack
2027046	 <p>Connector cover, one connection cable, dia. 6 mm (0.24 in), shielded, with 15-pin D Sub HD plug. Pin assignment see Chapter 5.3 Connector pin assignment, Page 5-7. Enclosure rating max. IP 65. Required: 1 per CLV490</p>	15 x 0.23 mm ² (24 AWG)	3 m (3.84 ft)	CLV490 to CDB420

Table 10-16: Accessories: Cables and connector covers for CLV490 without heater

Order No.	Description	Wires	Length	Connection
2030023	 <p>Connector cover with parameter memory (EEPROM), one connection cable, dia. 6 mm (0.24 in), shielded, with 15-pin D Sub HD plug. Pin assignment see Chapter 5.3 Connector pin assignment, Page 5-7. Enclosure rating max. IP 65. Required: 1 per CLV490</p>	15 x 0.23 mm ² (24 AWG)	3 m (3.84 ft)	CLV490 to CDB420
2020307	 <p>Connector cover with parameter memory (EEPROM), two connection cables, each with dia. 8 mm (0.32 in), shielded, with 15-pin D Sub HD socket and 15-pin D Sub HD plug. Pin assignment of each cable identical to device connection, however pin 13 and pin 14 of "I/O" connection not connected. Enclosure rating max. IP 65. Required: 1 per CLV490</p>	je 18 x 0.14 mm ² (26 AWG)	3 m (3.84 ft)	CLV490 to CDM490
2020981	 <p>Connector cover with parameter memory (EEPROM), two connection cables, each with dia. 8 mm (0.32 in), shielded, with two open ends (crimped wires). All pins connected, however pin 13 and pin 14 of "I/O" connection not connected. Enclosure rating max. IP 65. Required: 1 per CLV490</p>	je 18 x 0.14 mm ² (26 AWG)	3 m (3.84 ft)	CLV490 to host, sensors, PLC and non-SICK power pack
2014054	 <p>RS 232 data cable (null modem cable), dia. 5 mm (0.19 in), shielded, with two 9-pin D Sub sockets, (Pin2 (Rx)D) and Pin 3 (Tx)D) crossed</p>	3 x 0.34 mm ² (22 AWG)	3 m (3.84 ft)	PC to CDB420/ CDM490
6010088	Data cable, dia. 6.6 mm (0.26 in), shielded, for connection cables up to 3 m (3.84 ft)	15 x 0.09 mm ² (28 AWG)	Cut to size	Free wiring

Table 10-16: Accessories: Cables and connector covers for CLV490 without heater (contd.)

Note Other cable lengths/types for CLV490 without heater available on request.

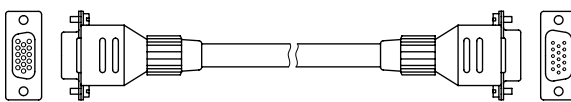
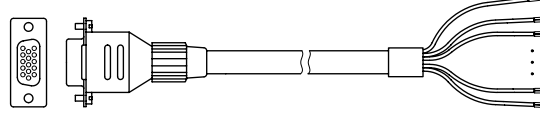
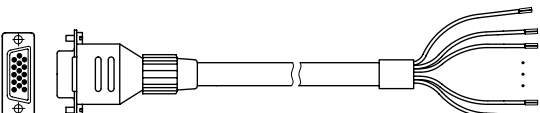
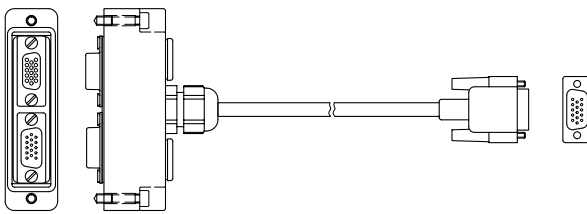
b) CLV490 with heater

Temperature range of connection material:

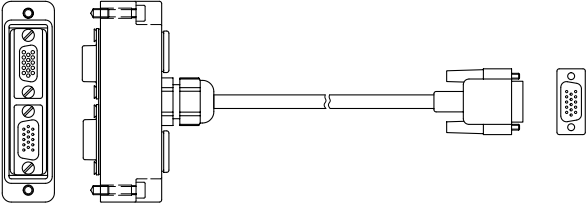
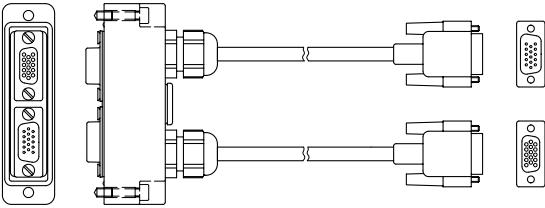
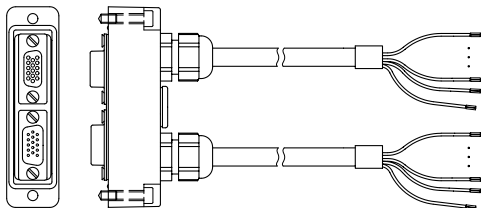
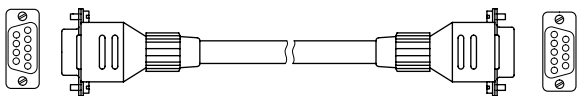
Stationary: -50 to +70 °C (-58 to +158 °F); moving: -40 to +70 °C (-40 to +158 °F)

Order No.	Description	Wires	Length	Connection
2033126	 <p>Connector cover with parameter memory (EEPROM), one connection cable, dia. 6 mm (0.24 in), shielded, with one 15-pin D Sub HD plug and one power supply cable, dia. 8.6 mm (0.34 in), shielded, open end (ferrules). Pin assignment see Chapter 5.3 Connector pin assignment, Page 5-7. Enclosure rating max. IP 65. Suitable for track chain use. Required: 1 per CLV490</p>	15 x 0.23 mm ² (24 AWG) + 2 x 1.5 mm ² (16 AWG)	10 m (32.8 ft)	CLV490 to CDB420
2033127	as 2033126, but longer	as 2033126	15 m (49.2 ft)	as above
2030065	 <p>Connector cover with parameter memory (EEPROM), two connection cables, each with dia. 6 mm (0.24 in), shielded, with one 15-pin D Sub HD socket and with one 15-pin D Sub HD plug. Power supply cable, dia. 8.6 mm (0.34 in), shielded, open end (ferrules). Pin assignment of each cable identical to device connection, however pin 13 and pin 14 of "I/O" connection not connected. Enclosure rating max. IP 65. Suitable for track chain use. Required: 1 per CLV490</p>	je 15 x 0.23 mm ² (24 AWG) + 2 x 1.5 mm ² (16 AWG)	3 m (3.84 ft)	CLV490 to CDM490
2031034	as 2030065, but longer	as 2030065	10 m (32.8 ft)	as above

Table 10-17: Accessories: Cables and connector covers for CLV490 with heater

Order No.	Description	Wires	Length	Connection
2021267	 <p>Connector cover, two connection cables, each with dia. 6.7 mm (0.26 in), shielded, with open ends (crimped wires). All pins connected, however pin 10 to pin 15 of "Host/Term" connection (CAN interfaces 1 and 2) not connected, pin 13 and pin 14 of "I/O" connection not connected. Enclosure rating max. IP 65. Required: 1 per CLV490</p>	je 18 x 0.14 mm ² (26 AWG) + 2 x 1.5 mm ² (16 AWG)	3 m (3.84 ft)	CLV490 to host, sensors, PLC and non-SICK power pack

Table 10-17: Accessories: Cables and connector covers for CLV490 with heater (contd.)

Note Other cable lengths/types for CLV490 with heater available on request.

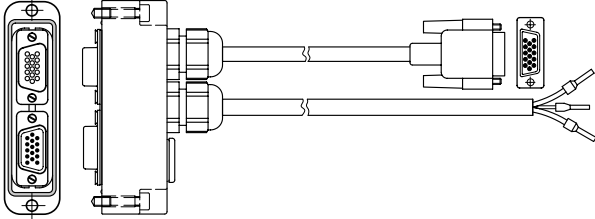
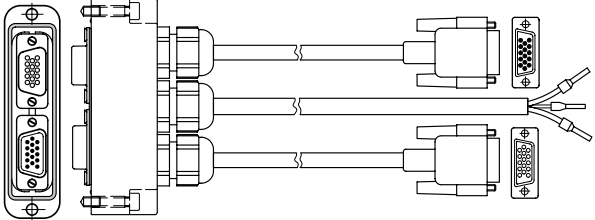
10.13.7 Plug-in connections

Order No.	Description
6009438	D Sub connector housing (metal) for 9-pin or 15-pin HD inserts
6007335	D Sub connector insert, 9-pin socket connector
6010019	D Sub connector insert, 15-pin HD socket connector
6010020	D Sub connector insert, 15-pin HD pin connector

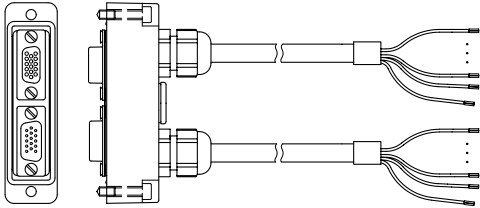
Table 10-18: Accessories: plug-in connections

10.13.8 Reading pulse generators

The SICK catalog "SENSICK Industrial Sensors" (no. 8006530, English edition) contains a large selection of photoelectric switches and photoelectric proximity switches as well as the associated accessories (brackets, connection cables).

10.13.9 Incremental encoder

Order No.	Description
2022714	Incremental encoder with friction wheel, resolution 10 mm (0.39 in) per pulse, max. 100 KHz, operating voltage 18 to 28 V DC, operating temperature 0 to +70 °C (+32 to +158 °F). With mounting bracket and accessories, connection cable 10 m (32.8 ft) with M12 socket and open end

Table 10-19: Accessories: incremental encoder

10.14 Dimensioned drawings of the accessories

10.14.1 Angle bracket, single no. 2013824

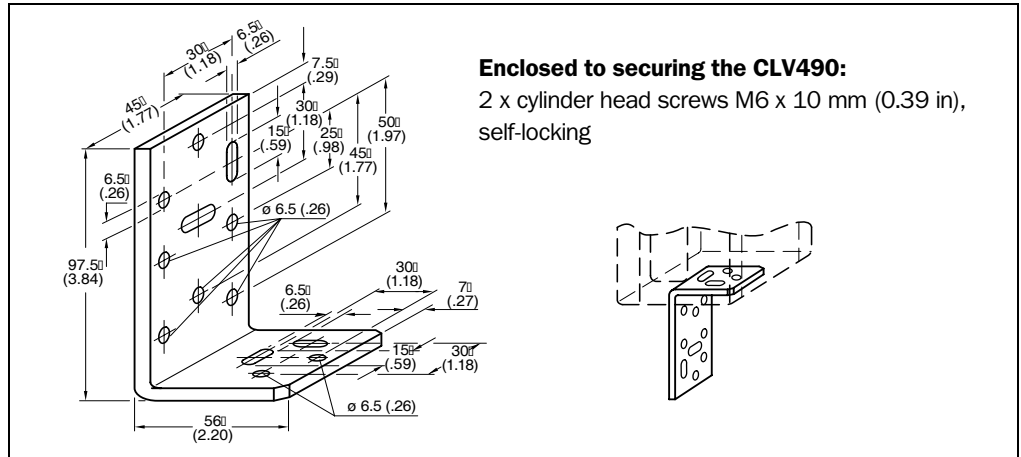

Fig. 10-58: Dimensions of the angle bracket, single No. 2013824

10.14.2 Articulated bracket, No. 2018435

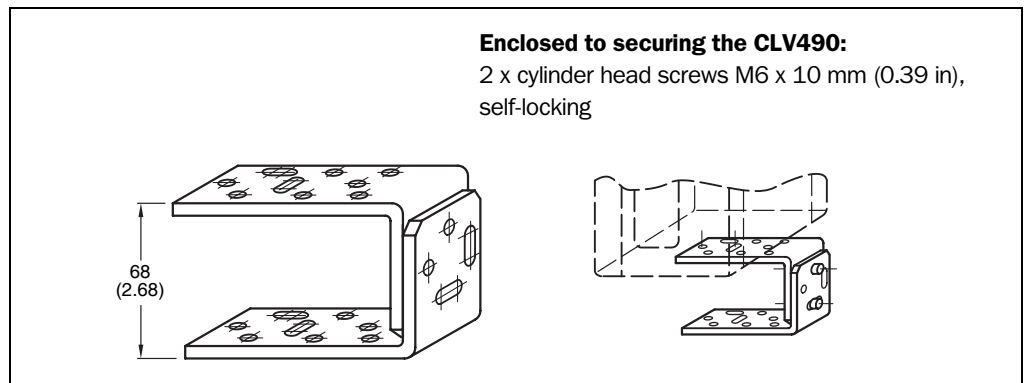

Fig. 10-59: Dimensions of the articulated bracket No. 2018435

10.14.3 Quick clamping device, No. 2016110

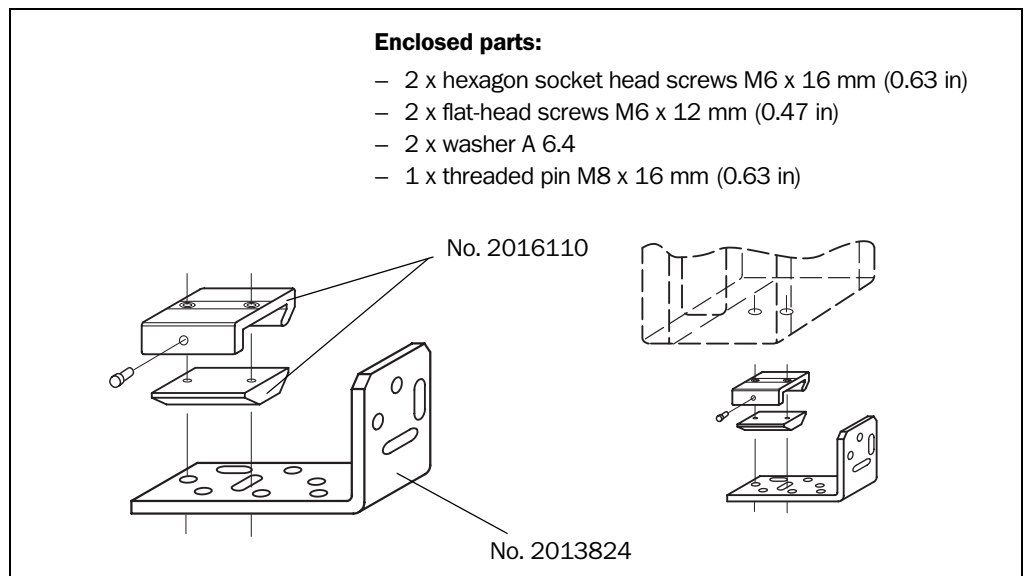

Fig. 10-60: Front view of quick clamping device No. 2016110 with angle bracket No. 2013824

10.15 Supplementary documentation

Order No.	Title	Language	Contents
8010001	"CDB420 Connection Module" Operating Instructions	German/ English	Description for connecting the CLV490 to the host/ PLC/sensor via the CDB420 Connection Module
8010005	"CDM490 Connection Module" Operating Instructions	German/ English	Description for connecting the CLV490 to the host/ PLC/sensor via the CDM490 Connection Module
8010002	"CMC400 Connection Module Cloning" Operating Instructions	German/ English	Description for installing the module in the CDB420 or CDM490 Connection Module
8010372	"CMD400 Connection Display Module" Operating Instructions	German/ English	Description for installing the module in the CDM490 Connection Module
8010601	"CMP490 Power Supply Module" Fitting Instructions	German/ English	Description for installing the module in the CDM490 Connection Module
8010462	"CMF400-1x01 Field Bus Gateway for Profibus-DP" Operating Instructions	English	Description for installing and setting up (configura- tion) the module in the CDM490 Connection Module
8010464	"CMF400-2101 Field Bus Gateway for DeviceNet" Operating Instructions	English	Description for installing and setting up (configura- tion) the module in the CDM490 Connection Module
8010735	"CMF400-2101 Field Bus Gateway for Ethernet TCP/IP" Operating Instructions	English	Description for installing and setting up (configura- tion) the module in the CDM490 Connection Module
8010971	"Cold-resistant cable no. 2033126/no. 2033127" Fitting Instructions	German/ English	Description of installing the cable on the CDB420
8010972	"Cold-resistant cable no. 2030065/no. 2031034" Fitting Instructions	German/ English	Description of installing the cable on the CDM490
8009180	"Application of the CAN interface" Operating Instructions	English	Description of building a CAN scanner network (elec- trical connection, configuration of the CLV, functions) and the integration into a CANopen network
8008869	"Omni Tracking System OTS400" Operating Instructions	English	Description of the integration of the CLV490 in an omnidirectional OPS reading system

Table 10-20: Supplementary documentation

10.15.1 CLV Connect (from version 1.9)

Diagrams showing you how to connect the CDB420 or CDM490 Connection Module are also available in the "CLV Connect" PC program. This software is available on the "Manuals & Software" CD-ROM, which is included in the scope of delivery of the CLV490.

The software can also be downloaded from the SICK home page (www.sick.com) at "Service&Support/Downloadpool".

It can be called up using a standard HTML browser (e. g. Internet Explorer™).

10.16 Glossary

For further terms, please refer to the "CLV-Setup Help".

Adjusting mode

Special operating mode that enables the center of the scan line to be positioned exactly on the object containing the bar code.

Aperture angle α

Angle within whose limits the laser beam is deflected by the polygon mirror wheel. A V-shaped range perpendicular to the scan direction, which must contain the bar code, is formed in front of the reading window. If only part of this aperture angle is used (part of the scan line symmetric around the center point), the depth of field for the focus position and resolution is greater.

Aspect ratio

Ratio code height (bar length) to code length (number of characters). Using the SMART Decoder even bar codes with very small code height can be read.

Autofocus function

Ability of the CLV490 to detect the distance of the objects without external sensors in order to adapt the focus position to the object distance.

Auxiliary input

Special function on \Rightarrow the auxiliary interface. Used to enter bar code data subsequently in order to complete reading results sent to the host.

Auxiliary interface

Auxiliary data interface (RS 232) on the CLV490 with fixed data output format. Used to connect the "CLV-Setup" program to the CLV490 so that it can operate and configure the device. Also used to output system and error messages. Can be assigned various functions.

Capture range

Zone around a moving bar code created by the CLV490 using the increment management and code position comparison functions. Enables bar codes with identical contents and code type to be separated.

Christmas tree effect

Effect caused by limiting the active scan line range (reading angle values) and oscillating amplitude (CW values) on the \Rightarrow line scanner with oscillating mirror. In this way, a uniform sharply defined window can be created in the reading field for each distance configuration, independent of the reading distance.

CLV-Setup

PC program that runs on Windows 95™/98™, Windows NT4.0™, Windows 2000™, Windows XP™ and is used to parameterize the CLV490 offline (adjust the device to the local conditions) and operate it online. The parameter set is exchanged with the CLV490 by \Rightarrow uploading and \Rightarrow downloading it.

CLV-Setup Help

Online help function that provides support for using the "CLV-Setup" program. The help function explains the CLV490 parameters and their permissible values and can be launched directly from CLV-Setup in an HTML browser, such as Internet Explorer™.

Code angle (CW value)

Current deflection range of the scan line (oscillating mirror) perpendicular to the scan direction when a bar code is recorded. Calculated by the CLV490 for each scan and used, for example, to define a capture range so that bar codes with identical data contents in a given range can be separated.

Code Info/Separator

Data block in the reading result on the ⇨ host interface. Used to provide additional information about the bar codes. Can be attached to the bar code as a prefix or suffix. Contains up to 10 elements, consisting of reading diagnosis data and/or constants (control characters, letters, digits), depending on the configuration. The "Code-Info/Separator" block is empty in the default setting of the CLV490.

Code geometry

Length and height dimensions of the bar code.

Command strings, commands

CLV490 user interface – alternative to the "CLV-Setup" program. Basic, yet clearly structured command language for modifying the CLV490 parameter sets online. Accesses the CLV490 command interpreter directly. Special programming activities are required to use the command strings from the host.

Configuration file

File in the "CLV-Setup" program that archives the entire ⇨ parameter set of the CLV490. Can also be printed out in tabular form.

Data forwarding

Option of forwarding data sent by the host transparently to a terminal via the CLV490 using an identifier. Data can also be forwarded in the opposite direction. Furthermore, this function also allows data received on one of the serial interfaces to be output again straight away on one of the same interfaces (echo). Application: forwarding reading results in pass-through mode, e. g. in a master/slave network.

Data output string

Structured data telegram in the ⇨ reading result output by the CLV490 on the ⇨ host interface. The structure of the data string is flexible and can be adapted to a large extent to the subsequent data processing task. The data output format of the ⇨ auxiliary interface, on the other hand, cannot be changed.

Decoder, decoding

Code-type-specific evaluation routine for reconstructing the read bar code in electronic form in order to decode its data content.

Deflection angle

Angle about each side of the center position $CW = 50$ (equal to 0°) that the \Rightarrow scan line sweeps when it is deflected by the oscillating mirror. Also referred to as the oscillating angle.

Deflection range

Deflection of the scan line caused by the \Rightarrow oscillating mirror, perpendicular to the scan direction about the center position $CW = 50$ at each side (corresponds to a deflection angle of 105°). Also referred to as oscillating amplitude. The maximum deflection range is set in OSCILLATING WITH FIXED AMPLITUDE mode. In OSCILLATING WITH VARIABLE AMPLITUDE mode, the deflection range is set for each distance configuration using the OSCILLATING MIRROR tab in the "CLV-Setup" program.

Distance configuration

Data record in the CLV490 for defining a \Rightarrow focus position for the laser beam for \Rightarrow dynamic focus control. The focus position as well as the maximum and minimum \Rightarrow reading angle must be entered on the READING CONFIGURATION tab in the "CLV-Setup" program for this purpose. In the case of the line scanner with oscillating mirror, the \Rightarrow oscillating amplitude (deflection range) is also required. The depths of field for the individual focus positions are shown as a function of the resolution values in the specification diagrams.

Download

Method of transferring the \Rightarrow parameter set that was modified with the \Rightarrow CLV-Setup program offline from the PC to the CLV490. CLV-Setup either always transfers a complete copy to the memory (RAM) of the CLV490 (DOWNLOAD TO CLV) or just the parameter previously processed using the context menu of the right mouse button (DOWNLOAD PARAMETER) or all parameters of the displayed tab (DOWNLOAD PARAMETERS OF THIS VIEW). You can overwrite the existing parameter set in EEPROM of the CLV490 by choosing the "Permanent" save option.

Dynamic focus control

Function for shifting the focal point of the laser beam across a wide range in the reading plane. The dynamic focus control function is event controlled (e. g. by the distance detector) or dynamic in the \Rightarrow Autofocus function.

Error messages

Messages in \Rightarrow plain text or coded (3-digit) that are used to identify a malfunction on the CLV490 in Reading mode. The messages are output on the auxiliary interface only. Exception: $ST = 3$ (device error), which is also output on the host interface. The error messages can be displayed in the Terminal emulator in the "CLV-Setup" program.

Error status

Identifier output with the reading result by the CLV490 for errors that were diagnosed while the bar code was being read. The entry for the host interface is made in the "Code-Info/ Separator" block of the \Rightarrow data output string and must be enabled using the parameters (for the CLV490 disabled by default).

Focus position

Distance of the focal point of the emitted laser beam in front of the reading window. Can be varied using the optical components in the CLV490. Creates a distance-specific depth of field (DOF) in which the bar code can be detected.

Functional interfaces

Switching inputs and outputs on the CLV490.

Good Read

The CLV490 successfully detected a bar code or the required number of bar codes specified by the evaluation parameters during the ⇒ reading pulse.

Header

Data block in the reading result on the ⇒ host interface. Used as a header in the ⇒ data output string for the subsequent data content of the bar codes. Contains up to 10 elements, consisting of reading diagnosis data and/or constants (control characters, letters, digits), depending on the configuration. The "Header" block is empty in the default setting of the CLV490.

Host interface

Main data interface on the CLV490 with configurable data output format. Used to output the ⇒ reading result in telegram form to the host/PLC. Integrates the CLV490 in the SICK network (RS 485) or builds a master/slave arrangement. Physically switchable to RS 232 or RS 422/485. It supports various transmission protocols.

Increment management

Used in certain applications to separate bar codes with identical contents that move during the reading procedure.

Line scanner

Scanner that uses a polygon mirror wheel with paraxial mirrors to deflect a focused laser beam extremely fast. As a result, it creates a light spot in the reading plane that moves along a straight line, which appears to the naked eye as a stationary scan line.

Line scanner with oscillating mirror

Line scanner that also deflects the laser beam about a central position, on both sides and perpendicular to the scan direction using an oscillating mirror. By doing so, the CLV490 can search for bar codes in larger areas. In addition to basic deflection with the maximum oscillating amplitude, optimum oscillating mirror functions are also possible (variable deflection per distance configuration, ⇒ One-Shot).

Master/slave configuration

Special arrangement for connecting up to max. 10 SICK bar code scanners in the CAN Scanner Network to one reading station (e. g. left/right read). Thanks to the master, the entire network appears as one device to the host.

Multiple read

Variable number of reading operations that must provide identical reading results (data content) of the same bar code before the CLV490 outputs the result.

No Read

The CLV490 failed to detect a bar code or the required number of bar codes specified by the evaluation parameters during the ⇒ reading pulse.

No Read format

Special, parameterizable data block as a substitute for bar codes, which were expected but not detected, in the data output string on the host interface for ⇒ No Read. Comprises a variable combination of the error string and the ⇒ "Code-Info/Separator" block.

Object polling

The CLV490 automatically detects a current object entering or leaving the reading field without any external sensors.

Omnidirectional reading

Arrangement of the scan lines of at least two CLVs which form a cross. Due to the max. tilt 45° of the CLV490 the position of a bar code to the scan lines is free.

One-Shot

Selective, one-off deflection of the oscillating mirror for each ⇒ reading pulse. Usually comprises a slow forward phase (read) and a fast return phase (return to starting position).

Oscillating mirror reversal point

Deflection point of the oscillating mirror at which it changes direction. Can be used to trigger a ⇒ focus position switchover for slower applications (search mode).

Parameter set

Data record used to initialize and activate the functions implemented in the CLV490. With ⇒ downloading and ⇒ uploading the parameter set is transferred from CLV-Setup to the CLV490 or from the CLV490 to CLV-Setup.

Parameter memory, external

Optional accessory containing an integrated connector cover. Enables devices to be conveniently replaced by storing a copy of the CLV490 parameter set (EEPROM). The replacement device then accesses this parameter set directly and does not have to be configured manually.

Percentage evaluation

Special operating mode in which the quality of the reads (not those of the bar codes, however) is assessed statistically. The bar codes must be stationary. The CLV490 carries out 100 scans and evaluates the reading quality. It then outputs the reading results on the ⇒ auxiliary interface every 2 s together with the ⇒ reading diagnosis data.

Plain text

Legible form of a CLV490 message. The CLV490 outputs special messages in coded form, e. g. the result of the self-test is represented as three digits.

Reading angle (RA value)

Position of the first dark bar in a detected bar code along the ⇒ scan line. Calculated by the CLV490 for each scan and can be used, for example, to separate bar codes with identical data contents. The active evaluation range in the scan line can be restricted for ⇒ decoding purposes by specifying the maximum and minimum reading angle value for the application.

Reading diagnosis data

Data directly derived from the reading procedure by the CLV490. This data enables the quality of the read to be assessed. The data is always output on the ⇨ auxiliary interface together with the reading result. Only output on the host interface if enabled on the DATA STRING tab in the "CLV-Setup" program (for the CLV490 disabled by default).

Reading field

In start/stop mode the reading field is the area between the start and stop sensors for the reading pulse in conveyor direction. In tracking mode the reading field is the area between the sensor for start/end of an object and the object release point (data output) (parameterized as a distance in conveyor direction), referred to the increments.

Reading field height

Length of the ⇨ scan line that is available for detecting the bar code in the reading plane. Due to the V-principle of beam generation, the reading field height is dependent on the reading distance.

Reading interval

Timeslot in which the CLV490 activates the laser diode and attempts to detect valid bar codes from the information read. The reading interval may be shorter than the external reading pulse, depending on the selected output mode for the reading result.

Reading pulse

Clock pulse applied externally to the CLV490 to trigger the internal ⇨ reading interval. Can be supplied by a photoelectric reflex switch or a command from the host on the serial interface.

Reading range (DOF)

Depth of field about the focal point of the laser beam on two sides. The extent of the reading range depends on the resolution and reading distance.

Reading result

Electronic representation of the data content of the read bar code together with the ⇨ reading diagnosis data in one ⇨ data output string that is generated after the reading pulse has elapsed. The reading result on the auxiliary interface has a fixed format (content and output format); the reading result on the host interface can be configured separately for Good Reads and No Reads. Special characters can also be added if necessary.

Result status output

Function of the four "Result 1" to "Result 4" switching outputs in Reading mode. Signals the status of the reading result without indicating its contents (e. g. Good Read). You can assign a status to each output on the DEVICE FUNCTION tab in CLV490. The "Read Result" LED is linked to the "Result 2" output.

Scan line

See line scanner.

Sending point

Point at which the reading result is output with respect to the start of the ⇨ reading pulse and the internal ⇨ reading interval.

SMART decoder

Specially developed ⇒ decoder for reading bar codes with an extremely small code height and for poor-quality or contaminated code prints.

Specification diagrams

Diagrams for reading the resolution-specific depth of field (DOF) for specific focus positions.

Splitter

Data block in the reading result of the ⇒ host interface. Used to separate the data content of the bar codes. Contains up to 5 elements, consisting of constants (control characters, letters, digits), depending on the configuration. The "Splitter" block is empty in the default setting of the CLV490.

Standard decoder

Tried-and-tested ⇒ decoder from the CLV490 product family. Suitable for applications with an adequate code height, limited tilt, and high-quality code prints.

Start/stop mode

With this type of separate reading pulse, only one object is located in the reading field for each reading pulse. If the CLV490 is used in a stand-alone configuration, the start and end of the reading pulse are controlled by external sensors, command strings, or with the free running mode of the CLV490. If used in conjunction with other CLVs in a master/slave arrangement including the OTC400 (e.g. omnidirectional 2-side reading), the CLV490 receives the reading pulses via the OTC400. In this case, the size of the reading field is determined by the distance between the two external sensors for starting (start of reading field) and stopping (end of reading field) the reading pulse. The minimum reading distance between two objects must always be greater than the size of the reading field. The devices are connected via the CAN interface.

Storage in the CLV490

The application-specific ⇒ parameter set can be stored temporarily or permanently in the CLV490. If it is stored temporarily in the RAM, it is lost as soon as the power supply is switched off. Parameter sets that are stored permanently are transferred to the EEPROM in the CLV490 and remain active as the current data record when the power supply is switched off. The default setting is not affected by this and is stored in a read-only memory (ROM).

Switching sequence

Focus control function for event-controlled switching. Sequence of focus position settings with associated depths of field. The numbers of the active ⇒ distance configurations are entered at the required position in the assignment table for this purpose.

System messages

Messages ⇒ in plain text used to output the operating status of the CLV490. The messages are output on the auxiliary interface only and can be displayed in extended mode in the TERMINAL EMULATOR of the "CLV-Setup" program.

Teach-in

Method of programming the information required to adjust the CLV490 to the reading application in Parameterization mode. Example: teaching in the background for the Autofocus function, also known as a \Rightarrow distance profile.

Terminator

Data block in the reading result on the \Rightarrow host interface. Used to terminate the data content of the bar code. Contains up to 10 elements, consisting of reading diagnosis data and/or constants (control characters, letters, digits), depending on the configuration. The "Terminator" block is empty in the default setting of the CLV490.

Tracking mode

With this type of continuous reading pulse, several objects are located consecutively in the reading field. To enable the read bar codes to be uniquely assigned to objects, a minimum gap has to be ensured between the objects and the conveyor increment signals have to be supplied. The CLV490 is used in conjunction with other CLVs in a network with the OTC400 (e.g. omnidirectional 3-side reading). The CLV490 receives pulse signals and increment values via the OTC400. In this case, the size of the reading field is determined by the distance between the external sensor for the start/end of the object at the start of the reading field and the object enable point (data output) of the OTC400 in the conveyor direction at the end of the reading field. The devices are connected via the CAN interface.

Upload

Method of transferring the \Rightarrow parameter set from the CLV490 to the PC \Rightarrow using the CLV-Setup program. CLV-Setup either transfers a complete copy of the current parameter set from the memory (RAM) of the CLV490 (UPLOAD TO CLV) or just the parameter previously processed using the context menu of the right mouse button (UPLOAD PARAMETER) or all parameters of the displayed tab (UPLOAD PARAMETERS OF THIS VIEW). Displays the current parameter values on the tabs. Prerequisite for modifying the current parameter set.

User interface

Windows-based PC software "CLV-Setup" for operating and configuring the CLV490.

10.17 EC Declaration of Conformity

Fig. 10-63 shows the scaled down copy of the EC Declaration of Conformity (page 1).

- The complete EC Declaration of Conformity with the listing of the device versions and the fulfilled standards can be requested from SICK AG.

SICK

EC Declaration of conformity

Ident-No. : 9053454 O639

The undersigned, representing the following manufacturer

SICK AG
 Nimburger Straße 11
 79276 Reute
 Deutschland

herewith declares that the product

CLV49. / CLX49.

is in conformity with the provisions of the following EC directive(s) (including all applicable amendments), and that the standards and/or technical specifications referenced in page 2 have been applied.

(place),...Reute..... (date)...*2004-07-21*..



.....

ppa. Pierenkemper
 (Manager Development
 Division Auto Ident)



.....

ppa. Walter
 (Manager Production
 Division Auto Ident)

Fig. 10-63: Copy of the Declaration of Conformity (Page 1, scaled down)

10.18 Index

A

- Abbreviations.....I-10
- Accessories
 - Dimensioned drawings..... 10-83
 - Order specifications 10-75, 10-76, 10-77, 10-79
- Adjusting mode
 - Function4-10
 - Starting the mode6-43
- Adjusting the CLV
 - Reading angles.....4-5
 - Steps.....4-8
- Aperture angle
 - Definition.....4-4
 - Max. value4-4
- Autofocus
 - Function3-7
 - Operating modes.....3-7
 - Parameterization.....6-12
- Auxiliary input
 - Function 10-69
 - Starting the mode 10-69
- Azimuth angle (Tilt)
 - Definition.....4-5
 - Limit values.....4-5

B

- Background Analysis.....6-47
- Background teach-in
 - Function 3-7, 6-12
 - Starting the mode6-44
- Bar code
 - Calculation the unknown bar code length 10-59
 - Distance to other codes.....10-58
 - Sample (scannable) 10-101
- Browser.....3-2
- Bus gateways
 - Order specification.....10-77
 - Overview5-5

C

- Cables
 - Overview5-2
- CAN Scanner Network
 - Building a network.....10-72
 - Interfaces5-7
 - Tab6-8
- CD ROM.....3-1
- CDB420/CDM490 Connection Modules
 - Block diagram for the CDB4205-3
 - Block diagram for the CDM4905-5
 - Connection cables for the CDB420.....5-3
 - Connection cables for the CDM490.....5-6
 - Function of the CDB4205-3
 - Function of the CDM4905-5
- Cleaning the CLV7-1
- CLV-Connect10-85
- CLV-Setup
 - Default settings.....10-46
 - Download.....6-6
 - Functions (overview) 10-49
 - Hot keys 10-49
 - Ini file.....10-52
 - Installation on the PC 10-43
 - Log file for serial communication..... 10-52
 - Starting.....10-46
 - Tabs (overview) 6-7
 - Unknown parameters..... 10-51
 - Upload.....6-6
 - User interface.....10-48
- CLV-Setup Help 10-50
- Code angle CW
 - Count direction 4-6
 - Output in the data string (host interface) 4-7
- Code Info/Separator 6-56
- Command strings
 - Function..... 10-52
 - Input into terminal emulator 10-53
 - Outputting in a file..... 10-54
- Configuration (parameterization)..... 6-5
- Connecting the PC.....5-21
- Connection diagrams.....5-3, 5-5
- Connection modules
 - Order specification 10-75
 - Overview.....5-1
- Connector cover
 - Function.....3-10
 - Pin assignment5-7

D

- Declaration of Conformity..... 10-94
- Decoder
 - SMART decoder 3-6
 - Standard decoder 3-6
- Default settings
 - CLV-Setup..... 10-46
 - Extract of CLV.....6-2
 - Printing the settings of CLV 6-1
- Depth of field (DOF)
 - Adjusting the radial pattern.....3-7
 - Diagrams.....10-1
- Device functions (interactively)
 - Start 6-58
- Device number GN5-16
- DeviceNet.....10-72
- Dimensioned drawings.....9-4
- Dismantling
 - Disposal.....7-3
 - Steps 4-14
- Disposal of the CLV 7-3
- Distance configuration
 - Function.....3-8
 - Parameterization 6-16
- Distance profile (background)
 - Function.....3-7
 - Learning.....6-44

Documentation additional	10-85	- Characteristic data	5-24
Download		- Connection	5-23
- Function	6-5	- Function	3-6
- Start Download	6-6	- Parameterization	6-38
E		Incremental sensor	
Electrical installation	5-1	- Application	3-2
EMC	9-2	- Electrical connecting	5-23
Enclosure rating (IP)	9-2	- Function	3-9
Error messages		- Installation	4-12
- Display in the Terminal Emulator	8-2	Indicators	3-11
- Function	3-7	Installation	
- List (CLV with external parameter memory)	8-5	- Electrical installation	5-1
- List (CLV without external parameter memory)	8-2	- Mounting	4-1
Error status in the reading result	8-7	- Overview	1-4
Ethernet	10-72	Intended use of CLV	2-1
Evaluation		Interfaces of CLV	
- Decoder types	3-6	- Functions	3-6
- Parameterization	6-36, 6-37	- Overview	5-1
F		- Pin assignment	5-7
Figures (overview)	I-13	L	
Firmware	I-2	Laser radiation	
Focus position switching		- Laser power	2-2
- Function	3-8	- Laser warning labels (content)	2-2
- Parameterization	6-12	- Protection class	2-2
- Trigger modes	3-8	- Protective circuits, internal	2-3
G		- Replacing the laser warning labels	4-2
Glossary	10-86	- User instructions	2-2
Good Read	6-40	- Wave length	2-2
H		Laser timeout	
Header	6-56	- Function	2-3
Heating		- Parameterization	6-36
- Behavior	10-40	LEDs	
- Connection cables	10-81	- Function (CLV with ext. param. memory)	3-12
- Design	10-40	- Function (CLV without ext. param. memory)	3-11
- Electrical connection	10-41	- Parameterization (Result 1(LED "Read Result"))	6-37
- Function	10-40	- Position	3-5
- Power consumption	10-41	Line scanner	
- Switching on delay	10-40	- Dimensional drawing	9-4
- System requirements	3-2	- Function	3-9
- Temperatur range	10-40	- Quick start	6-3
Host interface		- Technical data	9-1
- Connecting	5-20	M	
- Data output string	6-56	Malfunctions	
- Default setting	5-20	- Diagnosis and remedy	8-9
- Function	3-6	- Error messages	8-2
- Max. cable lengths	5-16	Messages (terminal interface)	6-59
- Monitoring in the Terminal Emulator	6-55	Method of operation	
- Parameterization	6-37	- Block diagram	3-6
- Select hardware	5-21	- Description	3-6
I		Monitoring host interface	
I/O monitor in increment trigger	6-48	- Function	6-55
Identical bar codes		- Starting the mode	6-55
- Function of RA, CW values	4-6	Mounting	
- Parameterizing the evaluation	6-36	- Accessories	4-1
- Separation	4-6	- Mounting the CLV	4-7
IN 0 ... IN 4 switching inputs		- Mounting the distance sensors	4-13
- Assignment table	5-24	- Preparations	4-1

CLV490 Bar Code Scanner

- Reading pulse sensor.....	4-11	- LEDs.....	3-11
Mounting bracket		- Mounting.....	10-36
- Dimensions.....	10-75, 10-83	- Operating.....	10-36
- Function.....	4-3	- Pin assignment.....	5-7
N		- Replacing the CLV.....	10-39
No Read.....	6-40	- Saving parameters after download.....	6-6
O		- Startup first time.....	10-37
Object polling		- Troubleshooting.....	8-3
- Function.....	6-26	Parameter set	
- Parameterization.....	6-25	- Download.....	6-6
Object tracking		- Function.....	6-5
- Function.....	6-28, 6-34	- Upload.....	6-6
- Parameterization.....	6-27, 6-34	Parameterization.....	10-60
One-Shot (oscillating mirror)		- Calculating parameter values.....	10-55
- Calculating parameter values for the CLV.....	10-57	- Function.....	6-5
- Function.....	6-19	- Guide.....	6-9
Online help.....	10-50	- Replacing a CLV.....	10-73
Operating		- With CLV-Setup.....	6-5
- Function of the LEDs.....	3-11	- With command strings.....	10-53
- With CLV-Setup.....	6-38	Percentage evaluation	
- With command strings.....	10-53	- Function.....	6-41
Operating data		- Function of "Read Result" LED.....	3-11
- Display.....	6-53	- Read result output.....	6-42
- Reset.....	6-53	- Start the mode.....	6-41
Operating modes		Pin assignment of CLV.....	5-7
- Adjusting mode.....	6-43	Pitch	
- Background analysis.....	6-47	- Definition.....	4-5
- Background teach-in.....	6-44	- Limit values.....	4-5
- I/O monitor in increment trigger.....	6-48	Power consumption.....	2-4
- Overview of modes.....	6-38	Power-up delay	
- Percentage evaluation.....	6-41	- Function.....	5-16
- Reading mode.....	6-38	- Parametrization.....	5-17
- Show RA-limits.....	6-46	Product features.....	3-3
Oscillating mirror		Profibus DP.....	10-72
- Deflection range, high density.....	10-26	Protection class.....	9-2
- Deflection range, low density.....	10-33	Q	
- Deflection range, standard density.....	10-15	Quick start.....	6-3
- Design.....	3-5	R	
- Dimensioned drawings.....	9-5	Reading angle RA	
- Function.....	3-10	- Count direction within the scanline.....	4-6
- Function in adjusting mode.....	6-43	- Output in the data string (host interface).....	4-7
- Function in background Teach-in.....	6-44	Reading area.....	3-8
- Function in reading mode.....	6-38	- Configuration.....	6-10
- Function in show RA-limits.....	6-46	Reading diagnosis	
- Function in the percentage evaluation.....	6-42	- Function.....	6-54
- Operation modes.....	6-17	- Starting the mode.....	6-54
- Parameterization.....	6-17	Reading distance	
- Quick Start.....	6-3	- Definition.....	4-4
- Reversal points.....	3-10	- Detection (external sensors).....	3-8
- Technical data.....	9-2	- Distance profile (background).....	3-7
- Troubleshooting.....	8-19	Reading field diagrams.....	10-1
P		Reading field height	
Parameter memory, external		- High density, line scanner.....	10-16
- Design.....	10-34	- High density, line scanner with osc. mirror.....	10-21
- Electrical connection.....	10-36	- Low density, line scanner.....	10-27
- Error messages.....	8-5	- Low density, line scanner with osc. mirror.....	10-31
- Function.....	10-35	- Standard density, line scanner.....	10-3

- Standard density, line scanner with osc. mirror	10-9	Self-test	
Reading mode		- Error messages.....	8-2
- Function.....	6-38	- Function	6-57
- Output of the reading result.....	6-38	- Starting the mode	6-57
- Troubleshooting.....	8-10	Sensor for distance detection	
Reading operation mode		- Electrical Connection	5-23
- Parameterization.....	6-21	- Function	4-13
- Start/stop mode.....	3-8	- Mounting.....	4-13
- Tracking mode	3-9	Sensor switching input	
Reading pulse sensor		- Characteristic data	5-22
- Electrical connecting.....	5-22	- Connecting.....	5-22
- Mounting.....	4-11	- Function	3-6
- Parametrization for trigger source.....	4-12	- Parameterization.....	6-22
Reading result		Separation of bar codes	
- Host interface.....	6-55	- CW value.....	4-6
- Terminal interface.....	6-39	- Minimum distance.....	10-58
- Troubleshooting.....	8-14	- Parameterization.....	6-36
Reading space		- RA value	4-6
- Function.....	6-10	Show RA-limits	
- Parameterization.....	6-11	- Function	6-46
Reading trigger		- Starting the mode	6-47
- End of reading interval via IN 4	3-2	SICK Homepage.....	1-2
- Function.....	3-6	SICK Support	8-20
- Parameterization.....	6-21	Skew	
- Trigger modes.....	3-6	- Definition.....	4-5
- Triggering via Terminal Emulator.....	6-39	- Limit values.....	4-5
- Troubleshooting.....	8-10	SMART decoder.....	3-6
Reading window		Software versions	1-2
- Cleaning.....	7-1	Specification diagrams.....	10-1
- Position	3-5	Splitter	6-56
Repair	8-20	Start/Stop mode	
Replacing a CLV		- Function	3-8
- Via CLV-Setup	10-73	- Parameterization.....	6-21, 6-30
- Via the external parameter memory	10-74	Start-up	6-3
Result 1 ... Result 4 switching outputs		Supply voltage.....	5-16
- Characteristic data.....	5-26	- Connecting.....	5-18
- Connecting	5-26	Surface reflection	
- Function.....	3-6	- Prevention.....	4-5
- Parameterization	6-37	Switching off the CLV.....	6-60
S		System messages	
Safety		- Display in the terminal emulator.....	6-59
- Authorized users.....	2-1	- Function	3-7
- Enclosure rating/protection class.....	9-2	- List of messages	10-42
- Features	3-3	System requirements	
- Intended use	2-1	- CLV with heater.....	3-3
- Laser radiation.....	2-2	- CLV without heater	3-2
- Notes on device.....	3-1	- Connection Modules.....	3-2
- Silicone	2-4	- Sensors.....	3-2
- Supply voltage.....	5-16	- Supply voltage	3-2
Scanning frequency		T	
- High density, line scanner.....	10-20	Tables (overview).....	1-10
- High density, line scanner with osc. mirror.....	10-25	Technical data.....	9-1
- Low density, line scanner	10-30	Terminal emulator.....	6-39
- Low density, line scanner with osc. mirror	10-32	Terminal interface	
- Standard density, line scanner	10-8	- Connecting.....	5-21
- Standard density, line scanner with osc. mirror... ..	10-14	- Data format	6-39
Scope of delivery.....	3-1	- Default setting.....	5-22

CLV490 Bar Code Scanner

- Function	3-6
- Max. cable length	4-2
- Operating modes.....	6-54
Terminator	6-56
Thread Blind hole	
- Dimensions.....	4-2
- Position.....	3-5
Tracking mode	
- Function	6-34
- Minimum gap	6-27, 6-33
- Parameterization.....	6-27, 6-33
Troubleshooting	
- Analysis and remedy.....	8-9
- Error messages.....	8-2
- Error status in the reading result.....	8-7
U	
Upload	
- Function	6-5
- Starting upload	6-6
V	
Variants of CLV.....	3-1
W	
Windows	3-2

10.19 Bar code example

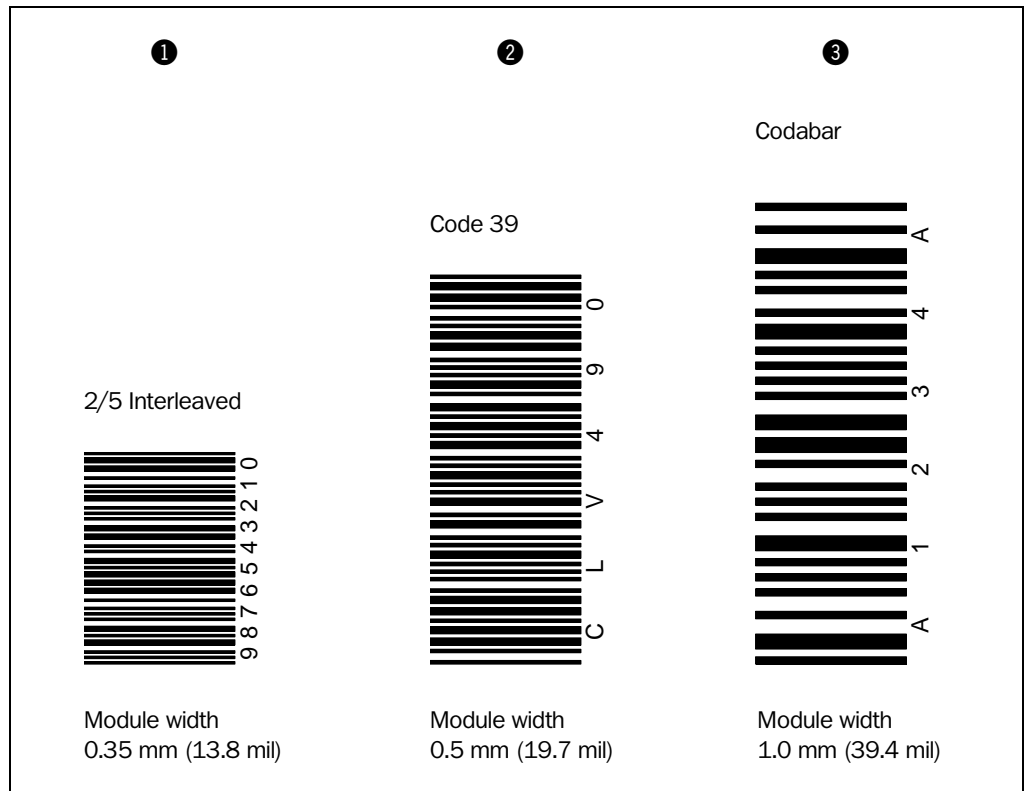

Fig. 10-64: Scannable bar codes with various module widths (print ratio 2:1)

Australia

Phone +61 3 9497 4100
1800 33 48 02 – tollfree
E-Mail sales@sick.com.au

Belgium/Luxembourg

Phone +32 (0)2 466 55 66
E-Mail info@sick.be

Brasil

Phone +55 11 5091-4900
E-Mail sac@sick.com.br

Ceská Republika

Phone +420 2 57 91 18 50
E-Mail sick@sick.cz

China

Phone +852-2763 6966
E-Mail ghk@sick.com.hk

Danmark

Phone +45 45 82 64 00
E-Mail sick@sick.dk

Deutschland

Phone +49 211 5301-270
E-Mail info@sick.de

España

Phone +34 93 480 31 00
E-Mail info@sick.es

France

Phone +33 1 64 62 35 00
E-Mail info@sick.fr

Great Britain

Phone +44 (0)1727 831121
E-Mail info@sick.co.uk

India

Phone +91-22-2822 7084
E-Mail info@sick-india.com

Italia

Phone +39 02 27 43 41
E-Mail info@sick.it

Japan

Phone +81 (0)3 3358 1341
E-Mail support@sick.jp

Nederlands

Phone +31 (0)30 229 25 44
E-Mail info@sick.nl

Norge

Phone +47 67 81 50 00
E-Mail austefjord@sick.no

Österreich

Phone +43 (0)22 36 62 28 8-0
E-Mail office@sick.at

Polska

Phone +48 22 837 40 50
E-Mail info@sick.pl

Republic of Korea

Phone +82-2 786 6321/4
E-Mail kang@sickkorea.net

Republika Slovenija

Phone +386 (0)1-47 69 990
E-Mail office@sick.si

Russia

Phone +7 495 775 05 34
E-Mail denis.kesaev@sick-
automation.ru

Schweiz

Phone +41 41 619 29 39
E-Mail contact@sick.ch

Singapore

Phone +65 6744 3732
E-Mail admin@sicksgp.com.sg

Suomi

Phone +358-9-25 15 800
E-Mail sick@sick.fi

Sverige

Phone +46 10 110 10 00
E-Mail info@sick.se

Taiwan

Phone +886 2 2365-6292
E-Mail sickgrc@ms6.hinet.net

Türkiye

Phone +90 216 587 74 00
E-Mail info@sick.com.tr

USA/Canada/México

Phone +1(952) 941-6780
1 800-325-7425 – tollfree
E-Mail info@sickusa.com

More representatives and agencies
in all major industrial nations at
www.sick.com